

DRYVAC

DV 450-i, DV 650-i, DV 1200-i,
DVR 5000-i, DVR 5000-f
Dry Compressing Vacuum Pumps

Operating Instructions 300304403_002_C0

Part Numbers

112045V50-1

112065V40-1 /45-1 /50-1

112120V40-1 /50-1

112500V40-1 /45-1 /50-1 /60-1
/61-1



Contents

	Page
0 Important Safety Information	5
Explanation of Warning Symbols	5
0.1 Mechanical Hazards	7
0.2 Electrical Hazards	9
0.3 Thermal Hazards	10
0.4 Hazards Caused by Materials and Substances	11
0.5 Ignition Risk	13
0.6 Noise Hazard	13
0.7 Dangers in connection with safety-related measures and precautions	13
0.8 Danger of Pump Damage	14
1 Description	16
1.1 Design	16
1.2 Supplied Equipment	21
1.3 Technical Data	22
1.4 Ordering Information	25
1.4.1 Pumps	25
1.4.2 Accessories	25
2 Transport and Storage	26
3 Installation	28
3.1 Placement	28
3.2 Conforming Use	30
3.2.1 Non-conforming Use	30
3.2.2 Pumping 100% Argon	32
3.3 Connecting the Intake and Exhaust Lines	32
3.3.1 Connecting Bellows	32
3.3.2 Intake Lines	34
3.3.3 Exhaust Lines	34
3.4 Connecting Cooling Water	36
3.4.1 Water Quality	38
3.5 Connecting Purge Gas	39
3.5.1 Guidelines for Purge Gas Operation, Settings and Monitoring	42
3.6 Electrical Connection	44
3.7 Leak Search after Installation	46

4	Operation	47
4.1	Media Compatibility	47
4.2	Profibus Interface for i-Version	47
4.3	Start-up	55
4.3.1	The Display Icons	59
4.4	Operation	60
4.4.1	Display Menu Items	60
4.4.2	Password handling	61
4.4.3	Setting Pump Configurations	63
4.4.4	Warning and Shut-off Thresholds	65
4.4.5	Failure list	66
4.4.6	Logging	68
4.4.7	Settings	70
4.5	Shut-off and Venting	73
4.6	Removing from Service	74
5	Maintenance	75
5.1	Leybold Service	75
5.2	Maintenance Intervals	75
5.3	Exchanging the Lubricant	76
5.4	Cleaning the Filter Insert in the Cooling Water Pressure Reducer	78
5.5	Replacing the Filter Cartridge in the Purge Gas Pressure Reducer	79
5.6	Fuse Replacement	80
6	Troubleshooting	81
6.1	Fault Messages of a Pump Stage	81
6.2	Alarm Messages of a Pump Stage	85
6.3	Alarm and Fault Messages DRYVAC	89
6.4	Pump Malfunctions	90
7	Wearing Parts	93
8	Waste Disposal	93
	EC Declaration of Conformity	94
	Certificates	95
	Index	97

Original installation and operating instructions.

Safety Information

NOTICE



Obligation to Provide Information

Before installing and commissioning the pump, carefully read these Operating Instructions and follow the information so as to ensure optimum and safe working right from the start.

The Leybold **DRYVAC** has been designed for safe and efficient operation when used properly and in accordance with these Operating Instructions. It is the responsibility of the user to carefully read and strictly observe all safety precautions described in this section and throughout the Operating Instructions. The pump must only be operated in the proper condition and under the conditions described in the Operating Instructions. It must be operated and maintained by trained personnel only. Consult local, state, and national agencies regarding specific requirements and regulations. Address any further safety, operation and/or maintenance questions to our nearest office.

DANGER



DANGER indicates an imminently hazardous situation which, if not avoided, will result in death or serious injury.

WARNING



WARNING indicates a potentially hazardous situation which, if not avoided, could result in death or serious injury.

CAUTION



CAUTION indicates a potentially hazardous situation which, if not avoided, could result in minor or moderate injury.

NOTICE









NOTICE is used to notify users of installation, operation, programming or maintenance information that is important, but not hazard related.



We reserve the right to alter the design or any data given in these Operating Instructions. The illustrations are not binding.

Retain the Operating Instructions for further use.







0 Important Safety Information

Explanation of Warning Symbols

 DANGER	
	<p>Toxic gases</p> <p>The pump must be leaktight. When the pump has been used to pump hazardous gases before, introduce appropriate safety precautions before opening it. Before opening the pump, purge it for a longer period of time with an inert gas. If necessary, wear gloves, breathing protection or protection clothing. If necessary, wear suitable personal protection equipment like gloves, breathing protection and protection clothing, for example.</p>
	
	
	
	

 WARNING	
	<p>Hazardous Voltage Disconnect power before opening Contact causes electrical shock</p> <p>High Leakage Current Earth connection essential before connecting supply</p> <p>Electrical Hazards Danger of residual voltage for up to 5 min after disconnecting power supply. Connect and disconnect the mains plug only in deenergized condition</p>
	<p>Hot Surface Do not touch. Allow this area to cool before servicing</p> <p>Burn hazard Hot Surface inside. Do not touch, wear protective equipment.</p>

Safety Information

 ATTENTION	
	<p>Purge gas Check compatibility with applications</p> <p>Overpressure in the discharge line Components can be thrown in all directions. The pressure in the discharge line must not exceed atmospheric pressure by 200 mbar max. The discharge line must not be blocked or restricted.</p>
	<p>Pumps with wheels must only be placed and moved on levelled horizontal surfaces!</p>
	<p>Vacuum Avoid exposing any part of the human body to the vacuum.</p>
	<p>Machinery starts automatically Connect the pump so that it not will restart automatically after a mains power failure, once the power returns.</p>
	<p>Overhead load Transport the pump only at the four crane eyes or secured with a forklift.</p>

0.1 Mechanical Hazards

- 1 In order to avoid the destruction of systems and injury to operating personnel we urgently recommend to observe the information and installation information provided in these Operating Instructions.
- 2 Avoid exposing any part of the human body to the vacuum.
- 3 Do not operate the pump with an opened intake port. There exists the risk of suffering injury.
- 4 The pump is intended for generating a vacuum only. If an **overpressure** can occur in the pump and the system then they must be protected against such an overpressure by an overpressure safety valve, for example.
- 5 The maximum permissible discharge pressure for the DRYVAC is 1.2 bar abs.

Always operate the pump with a connected exhaust line. The exhaust line must be designed for the specific kind of application and shall be connected to a central exhaust gas system.

Make sure that the gas flow at the discharge is not blocked or restricted in any way, even when the pumped out gases need to be collected or contained.

No shutoff devices are required in the discharge line for pump operation. If shutoff devices are installed, open them before starting the pump.

In the case of processes involving much condensate, we recommend the installation of a condensate separator in the discharge line.

- 6 When using purge gas, protect the purge gas supply so that in the event of a malfunction or power interruption no overpressure can occur within the pump system.
- 7 We recommend to design the discharge line in consideration of a possible overpressure of 5 bar. In the event of a malfunction, such a pressure can occur briefly.
- 8 For **transporting** the pump use only suitable transport means.
When selecting the lifting and transport means take note of the total weight before transporting the pump.
As standard, the pump has been equipped with four crane eyes.
When transporting the pump with a forklift or similar, ensure that the pump has been secured on the forks or on a suitable pallet.
The lifting eye of the screw pump must never be used to lift any pump combinations (Roots pump + backing pump).

WARNING



Safety Information

- 9 Select the location where the pump is installed so that all controls can be easily accessed. Place the pump only on a floor which is level. It can topple when it is tilted by more than 10° with respect to the vertical axis.

Because of the fitted castors, the pump must only be placed on a level floor capable of supporting the pump's weight, as otherwise there exists the risk of the pump rolling away. Moreover, the pump may only be moved on a level floor! Moving the pump along sloping paths or ramps is prohibited! The pump must only be transported with a forklift or a crane! At the installation location, screw down the adjustable feet.

- 10 Before beginning with any maintenance and servicing work always ensure that **no gas can flow backwards** through the pump since then the rotors might turn against the normal direction of rotation. For this reason vent the vacuum chamber to the discharge pressure level or ensure through suitable valves that the vacuum chamber and the lines are reliably separated from the pump. When connecting several pump systems, pressure differences between inlet and discharge can give rise to uncontrolled turning of the pump's shafts.
 - 11 During operation, the cooling water circuit must not be shut off. A cooling water discharge which has been blocked can cause the formation of gas bubbles and result in excessively high pressures.
 - 12 Lay electric feed and cooling water lines so that there is no risk of **tripping** over these.
 - 13 When changing the oil remove any escaped oil as otherwise there is the risk of slipping.
 - 14 Before doing installation work on the pump system make sure that no vacuum is present in the pump and that all media connections have been depressurised.
 - 15 Before disassembling any cooling water lines, leave the pump to cool down, shut off the feed line.
-

0.2 Electrical Hazards

- 1 The electrical connection must only be provided by a trained person. Please observe the national regulations in the country of use like EN 50110-1 for Europe, for example.
- 2 Potentially lethal voltages are present at the mains connections. Before beginning with any maintenance or service work on the pump, disconnect the pump from all power supplies (lockout/tagout). In addition, there is the danger of residual voltage for up to 5 min after disconnection.
- 3 Install a device for a safe disconnection from the power supply.
- 4 Plug or unplug the Harting mains connector only when no voltage is present.
- 5 High electric voltages! When touching parts at high electric voltages, there is the risk of suffering severe injuries by an electric shock! Covers marked with this symbol must only be opened by trained electricians after having reliably deenergised (lockout/tagout) the equipment.
- 6 Note the information on the IP type of protection.
- 7 Always operate the pump with a properly connected protective earth conductor and make sure that the motor casing is closed
- 8 Observe the manufacturer's information and operating instructions for the respective frequency converter.
- 9 The pump must only be operated at the frequency specified for the motor. Use only the Leybold frequency converter.
- 10 Install a suitable motor protection for the electric motor before starting up for the first time. Note the information in these Operating Instructions and on the nameplate.
- 11 Before starting, check to ensure that the junction box is undamaged, run a visual inspection on the seals.
- 12 Install add-on parts (pressure switches, for example) without any mechanical tensions and protect these against being damaged by impacts, for example.
- 13 Lay the connecting lines so that these cannot be damaged. Protect the lines against humidity and contact with water. Avoid thermally stressing the lines by unfavourable laying. Comply with the required standards when designing and laying the electrical connections.
- 14 Provide strain relief for the connecting lines so that the plugs and the line connectors are not subjected to excessively high mechanical stresses.
- 15 Lay electric feed lines so that there is no risk of **tripping** over these.

DANGER



Safety Information

- 16 The pump must be integrated in the system control arrangement so that it can not run-up automatically after it has been shut down due to overtemperature. This applies equally to emergency shut-down arrangements. After having determined the fault cause, the pump should be switched on manually again.
- 17 Work on the frequency converter within the motor casing must always be left to suitably instructed personnel only.

CAUTION



0.3 Thermal Hazards

- 1 Under certain ambient conditions parts of the pump may attain temperatures over 80° C. There then exists the risk of suffering burns when the covers are open. Note the danger symbols on the pump and in the case of a hot pump wear the required protection equipment. All work on a pump which is “still warm from operation” should be done only whilst wearing protective gloves.
If there is the risk of touching hot surfaces inadvertently, install corresponding protection. When working on a pump which is still warm from operation, always wear protective gloves.
 - 2 Handle the pump only while vented and after having let it cool down.
 - 3 Before disassembling any cooling water lines, leave the pump to cool down, shut off the feed line.
 - 4 When uninstalling the cooling water lines, take note of splashing water. Heated water can cause burns.
 - 5 Never remove the oil-fill or oil-drain plugs while the pump is running. There exists the risk of suffering burns. Always wear protective gloves and protective goggles also for protection against the oil.
 - 6 Operating the pump with less than the specified amount of cooling water will result in excessively high surface temperatures. There exists the risk of suffering burns.
-

0.4 Hazards Caused by Materials and Substances

- 1 The vacuum and exhaust lines must both be leaktight. **Hazardous process gases** may escape or the pumped gases can react with air or atmospheric humidity. After installation of the pump and after servicing work on the vacuum system, a leak search will always be necessary.

When pumping hazardous gases we recommend a leak search on a regular basis. Leaks in the pump cannot be ruled out under all circumstances. When pumping hazardous gases, the operator must ensure that that leaks at the pump will not be a hazard.

- 2 Since not all application related hazards for vacuum systems can be described in detail in these Operating Instructions, Leybold has available a separate document (Safety Booklet) in which the hazards and general safety concepts for design, operation and maintenance of vacuum systems are explained.

When planning to pump hazardous substances with this pump, read the related chapters in the Safety Booklet and in these Operating Instructions first. You can download the Safety Booklet from our homepage.

- 3 Before commissioning the pump, make sure that the media which are to be pumped are compatible with each other so as to avoid hazardous situations.
- 4 If required additional monitoring of the purge gas quantities is necessary from the side of the operator when a well-defined and ensured dilution is necessary from the side of the process.

The type of protection depends on the specific process and needs to be assessed by of the customer.

- 5 The cooling water from the return is not of drinking water quality and should not be used for this purpose.

After having operated the pump, the cooling water lines may suffer from microbiological contamination. Take appropriate safety precautions.

- 6 Before operating the pump with a gas ballast or a purge gas (option) check the compatibility of the gas with the pumped media so as to avoid dangerous conditions during operation.

- 7 When operating the pump with a purge gas valve, secure the purge gas supply so that in the event of a malfunction no overpressure can occur in the system.

DANGER



Safety Information

- 8 When the pump has been used to pump hazardous gases before, introduce appropriate safety precautions before opening the intake or the discharge connections. Before opening the pump, purge it for a longer period of time with an inert gas. If necessary, wear suitable personal protection equipment like gloves, breathing protection and protection clothing, for example (see Material Safety Data Sheets for the substances in use, the chemical reactions and the by-products). Firmly seal off the pump. When shipping the decontaminated pump for servicing please also indicate the type of hazard. For this see Section 5.1 Service at Leybold.
- 9 Leybold is not in a position to perform servicing (repairs) and waste disposal of radioactively contaminated pumps. Both needs to be ensured from the side of the user.
- 10 When disposing of the pump, used lubricants and used oil filters observe the applicable environment regulations.
- 11 When pumping hazardous gases you must assume the presence of hazardous residues in the pump.
- 12 If the pump has been contaminated by the process or through environmental influences, it must be decontaminated professionally.

Contaminated parts can be detrimental to health and the environment. Before beginning with any repair and maintenance work inform yourself about any possible contamination. When handling contaminated parts observe the pertinent regulations and comply with the necessary protection measures.

When shipping contaminated pumps which require approval by the authorities, note the applicable regulations regarding packaging and shipping.



- 13 Some pumps use perfluoropolyether (**PFPE**) as lubricant. When handling PFPE you should observe the following:
During thermal decomposition at temperatures over 290 °C toxic and corrosive gases are released. When handling PFPE keep it away from open fires. Do not smoke with PFPE on your fingers.
Touch the inner sections of the pumps only while wearing clean gloves, and use clean tools;
do the necessary work in clean and dry rooms;
after having removed the pump from its packaging, start it up as quickly as possible;
as cleaning agents solvents based on hydrofluorether compounds may be used.
- 14 Fluoropolymers are used as sealants (FKM) and as lubricants (PFPE) in the pumps. In case the pump suffers a severe mechanical failure, the possibility of hazardous substances being released owing to their thermal decomposition cannot be excluded. The hazards caused by such decomposition are described in the Material Safety Data Sheets for the materials, for example.

0.5 Ignition Risk

- 1 The standard version of the pump is not suited for operation in explosion hazard areas. Contact us before planning to use the pump under such circumstances.

DANGER



0.6 Noise Hazard

- 1 The noise level of the pump during ultimate pressure operation with silencer or connected discharge line corresponds to the values stated in the Technical Data. In other operating modes and with other equipment, higher values must be expected. Make sure that suitable protection measures are taken to protect your hearing.

We recommend to wear hearing protectors (earmuffs), if local noise levels exceed mandatory limits.

CAUTION



0.7 Dangers in connection with safety-related measures and precautions

- 1 The pump is not equipped with an emergency shutdown facility.
- 2 The following applies to pumps being operated with a frequency converter: after a mains power failure the pump will automatically start up again once the power returns.
- 3 Take note of the warning information on the casing surface. If this warning information was removed, covered or obstructed, then provide corresponding additional warning information.

CAUTION



NOTICE

0.8 Danger of Pump Damage

- 1 Select an installation site for the pump so that all controls are easily accessible.
- 2 The pumps are supplied filled with lubricant (synthetic oil or PFPE). For this reason they should, while being transported or shipped, not be subjected to much tilting. Store the pumps only horizontally standing on their feet.
- 3 Do not allow the ingestion of any objects (screws, welding beads, nuts, washers, pieces of wire, etc.) through the intake port of the pump.

If possible, use the **intake screen** which has been fitted as standard and clean it regularly.

In case the pump is operated without intake screen the operator has to make sure that no objects can enter the pump through the intake port. Objects falling into the pump can cause severe damage at the pump including leaks to atmosphere.

The intake screen does not replace a filter. Prevent the intake of particles from the side of the process by fitting suitable filters. Upstream filters protect the pump against damage to the pump chamber.

In a pumping section (combination of several pumps connected in series) only a single intake screen is required. This screen needs to be fitted to the inlet for the pump closest to the process chamber.

- 4 When pumping dust containing media, install a dust filter in the process gas flow upstream with respect to the pump. Consult with us.
- 5 If low concentration corrosive or reactive gases are being pumped, then operate the pump with purge gas.

Please consult us to determine which pump types are required for specific processes and applications.

- 6 When connecting the pump, provide a suitable valve on the intake side for the purpose of shutting off the intake line so as to prevent the pump from turning backwards in the event of a power failure. Otherwise the pump may suffer damage or oil may contaminate the pump chamber.
- 7 Lines and other vacuum connections should be clean and free of oil. Special attention must be paid here when oil-sealed pumps have been used on the vacuum side. Check the conditions before initial commissioning. In the case of deviations, the pump can suffer contamination with oil residues.
- 8 The pressure within a pump which has been switched off will increase to ambient pressure within a few seconds. In such a case the pump is vented through the discharge. We recommend to fit a **non return discharge valve**.
- 9 The **discharge line** should be laid so that it slopes down and away from the pump so as to prevent condensed vapours from backstreaming into the pump.

Safety Information

- 10 In the case of wet processes we recommend the installation of **liquid separators**, upstream and downstream of the pump so as to avoid the influx of liquid into the pump.
- 11 During installation work on the intake and discharge lines do not subject flanges to any stresses. Check the rubber elements of the pump's feet as to any deformation.
- 12 Before pumping **condensable vapours** the pump should be at operating temperature. If a gas ballast is present, then it should be opened. The pump will attain its operating temperature approximately 30 minutes after having started the pump. During this warm-up phase, the pump should be left separated from the process by a valve in the intake line, for example.
- 13 With the pump warm from operation do not clean it from the outside with water. There is the risk of a rotor crash due to shock cooling.
- 14 If condensable vapours have been pumped, the pump should before switching off be purged with an inert gas or air (depending on the specific application). This process should also be run before cleaning the pump chamber.
- 15 Improper decommissioning of the pump may damage it. For this reason, follow the instructions given in Sections 4.5 and 4.6 of these Operating Instructions.
- 16 Improper maintenance or repair work can have an influence on the service life and the performance of the pump and will void any warranty claims.
- 17 Maximum **cooling water pressure**: 7 bar. When exceeded, there is the risk of leaks.

Pressures given in bar or mbar are absolute values. If exceptionally a gauge pressure is meant, a "g" is added (bar(g)).

Description

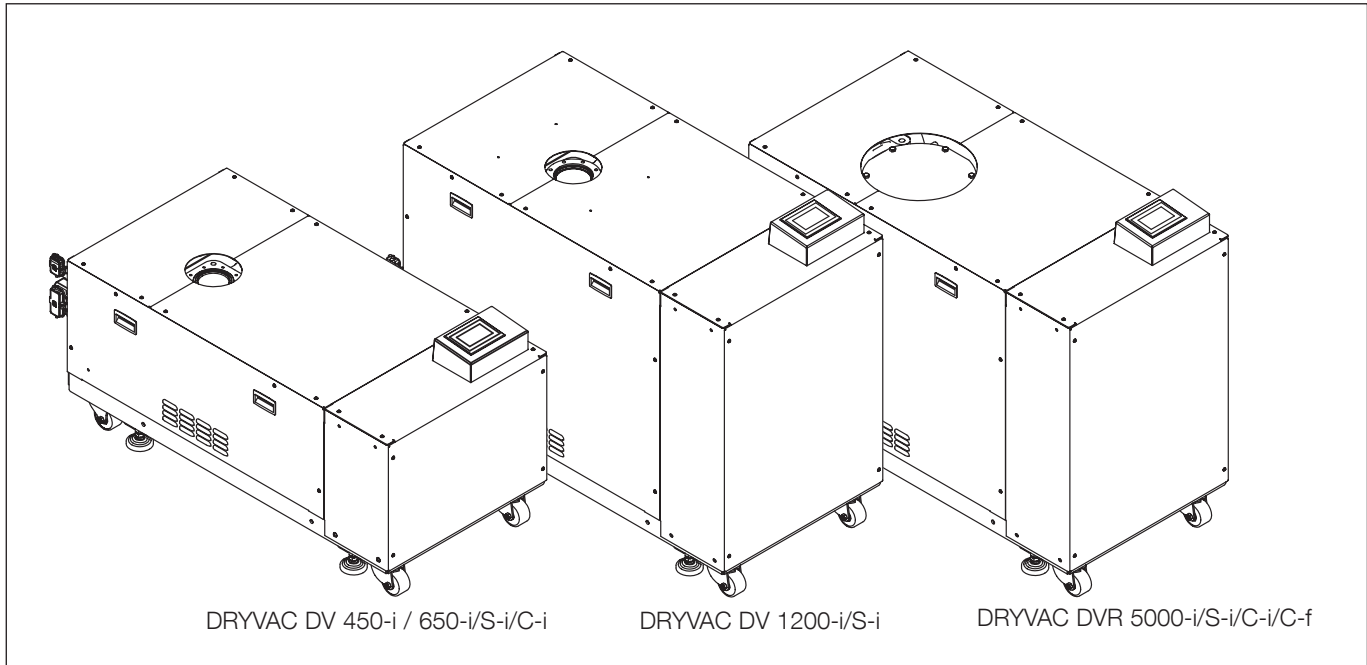

Fig. 1.1 Pump models

1 Description

1.1 Design

The DRYVAC is a dry compressing vacuum pump. The DRYVAC DV 450 and 650 each have one screw pump stage, the DRYVAC DV 1200 two screw pump stages, the DRYVAC DVR 5000 a Roots and a screw pump stage. Except for the sealing materials the DVR 5000 C-f pumps are identical to the DVR 5000 C-i pumps.

We offer different pump models for different applications.

DRYVAC S versions have optimized pumping speeds at pressures >100 mbar. Therefore, they provide fast pump down times. These models are specially suited for short cycle operation, e.g. load lock applications.

Models from the **DRYVAC C** range have been designed to provide reliability in harsh process duties. They are optimized for handling typical gases from the production in the PV and FPD industry. They excel through their robust design and meet industrial safety requirements. They are equipped with a purge gas system that makes possible rotor purge and shaft seal purge.

All described DRYVACs are equipped with

- on-board frequency converter
- PLC with touchscreen
- Profibus interface
- Check valve
- housing, castors and adjustable feet

They are water-cooled and lubricated either with synthetic oil or PFPE.

Description

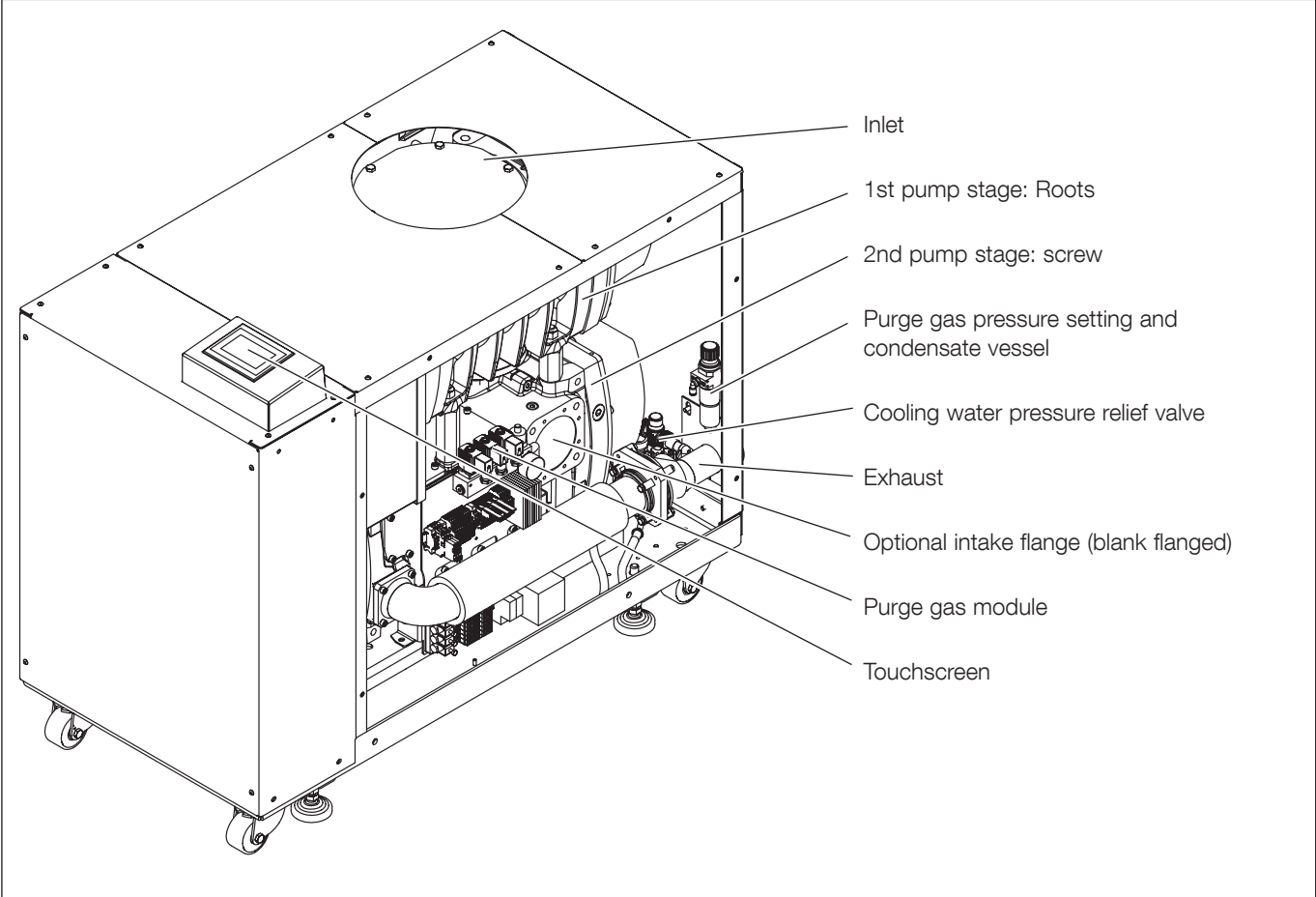

Fig. 1.2 DRYVAC DVR 5000 C-i without side covers

Description

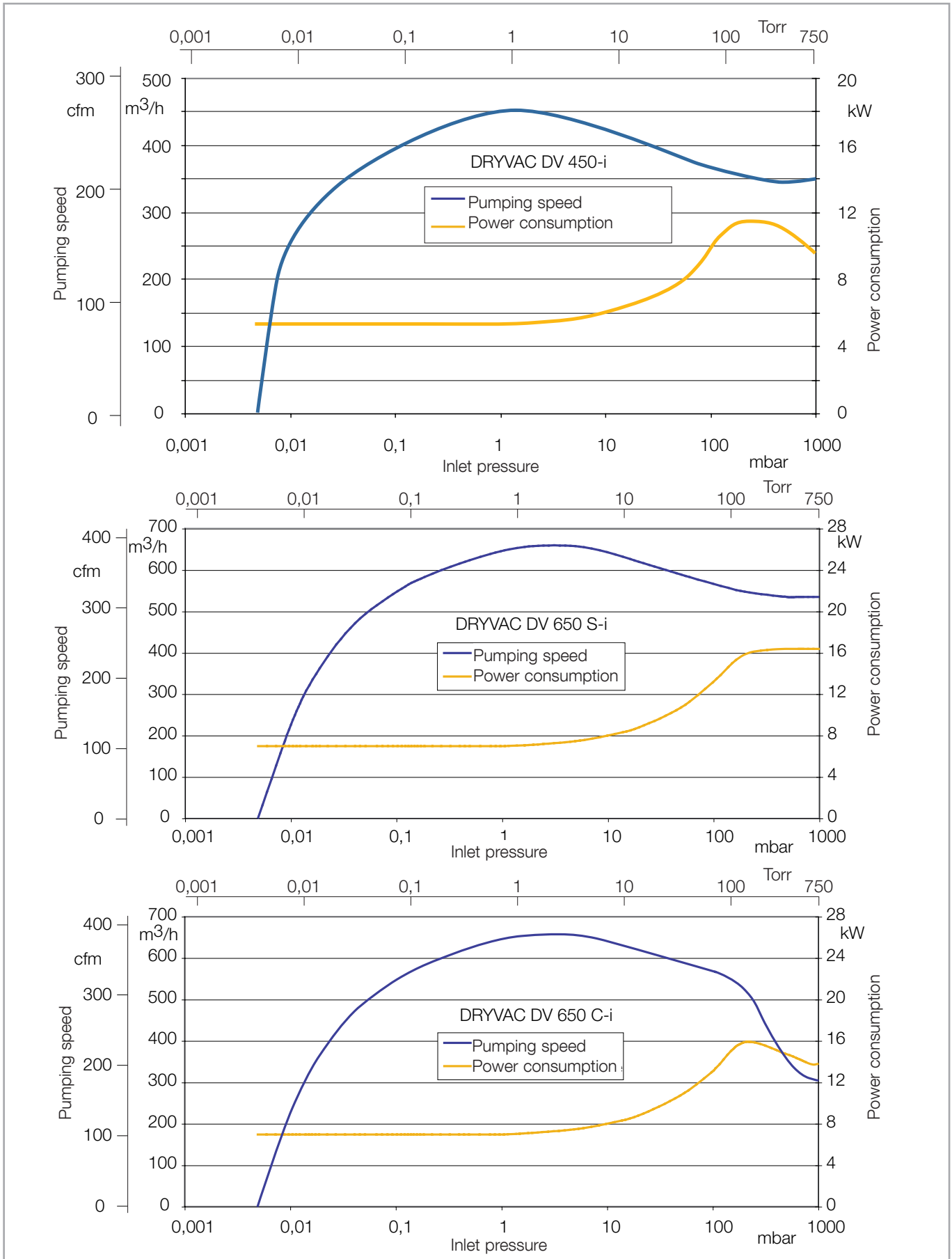

Fig. 1.3 Pumping speed curves

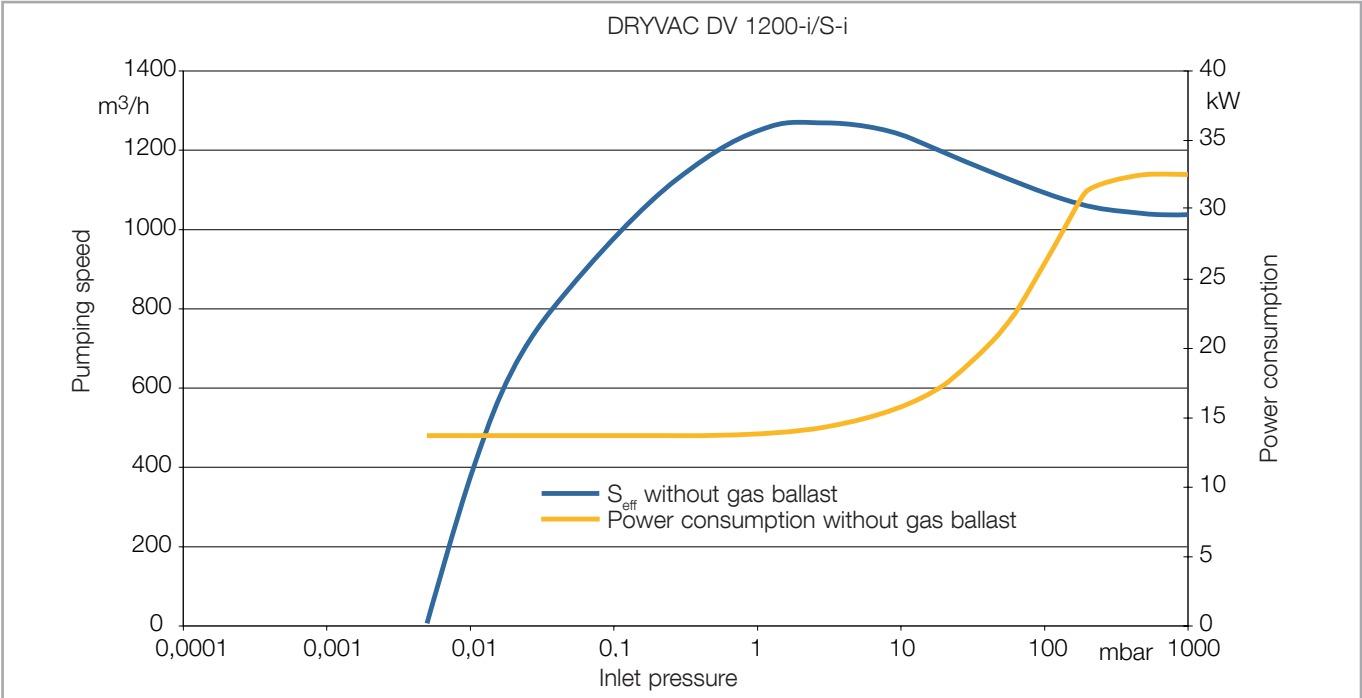

Fig. 1.4 Pumping speed curves

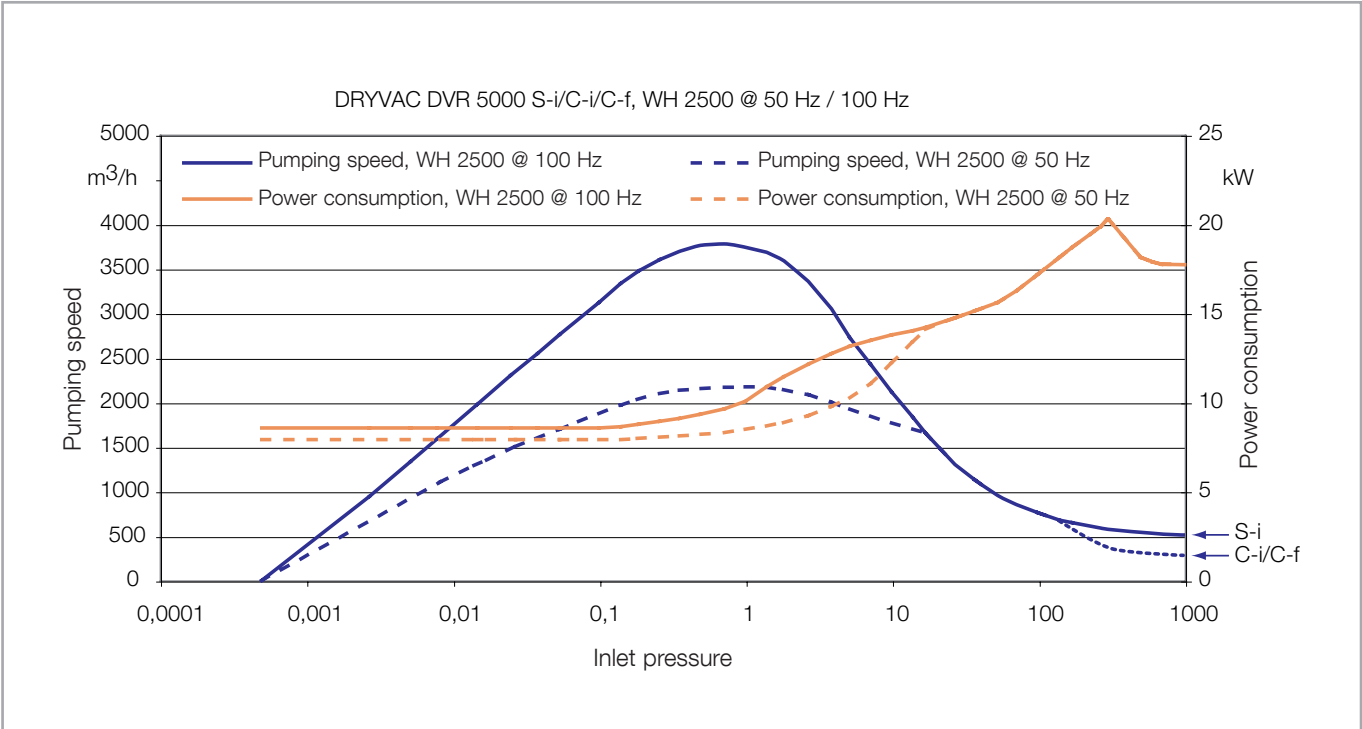

Fig. 1.5 Pumping speed curves

Description

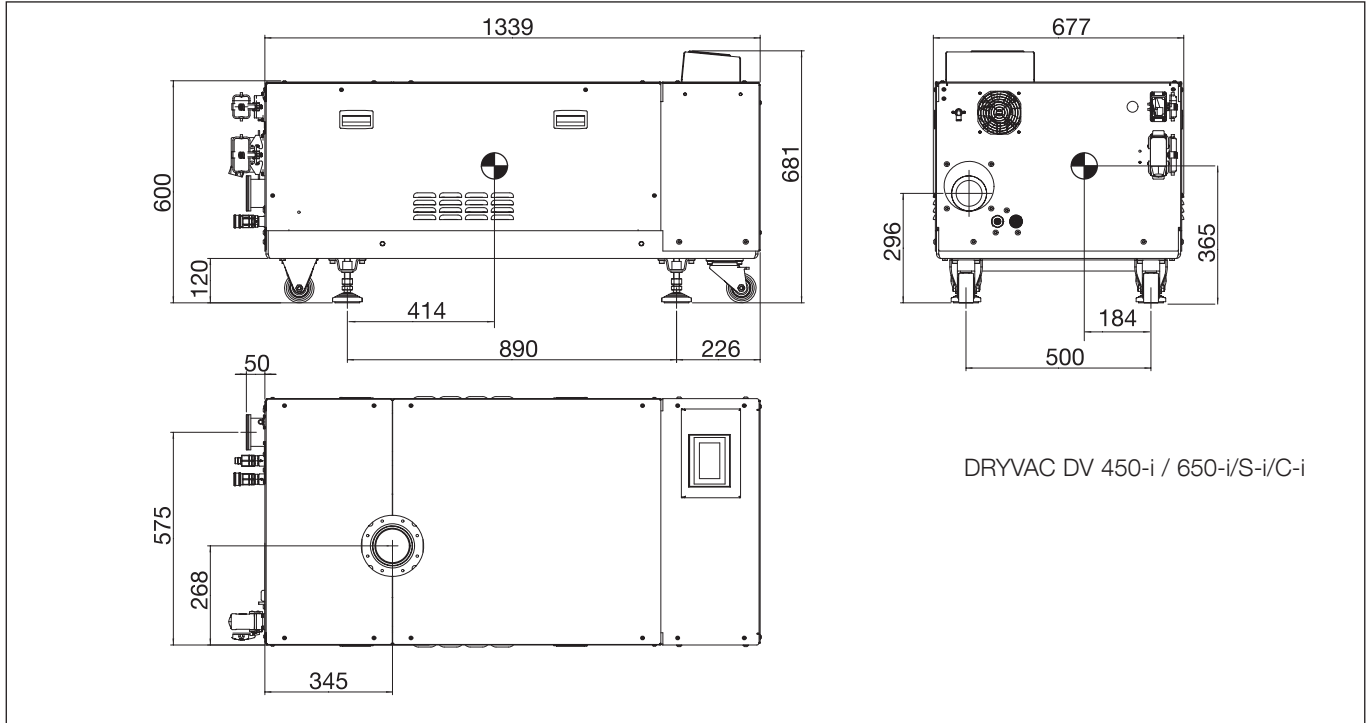

Fig. 1.6 Dimensional drawings, dimensions in mm

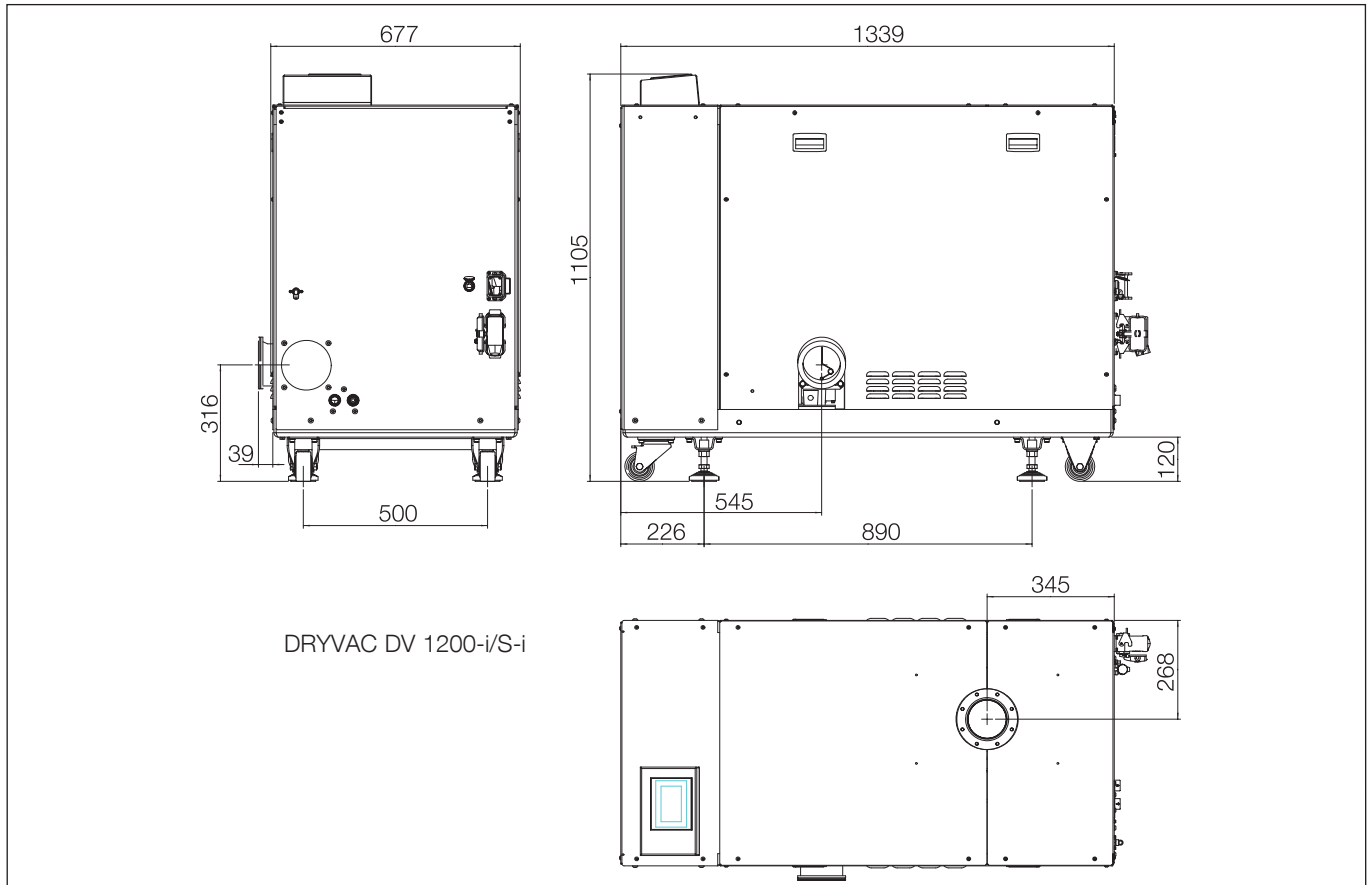

Fig. 1.7 Dimensional drawing, dimensions in mm

Description

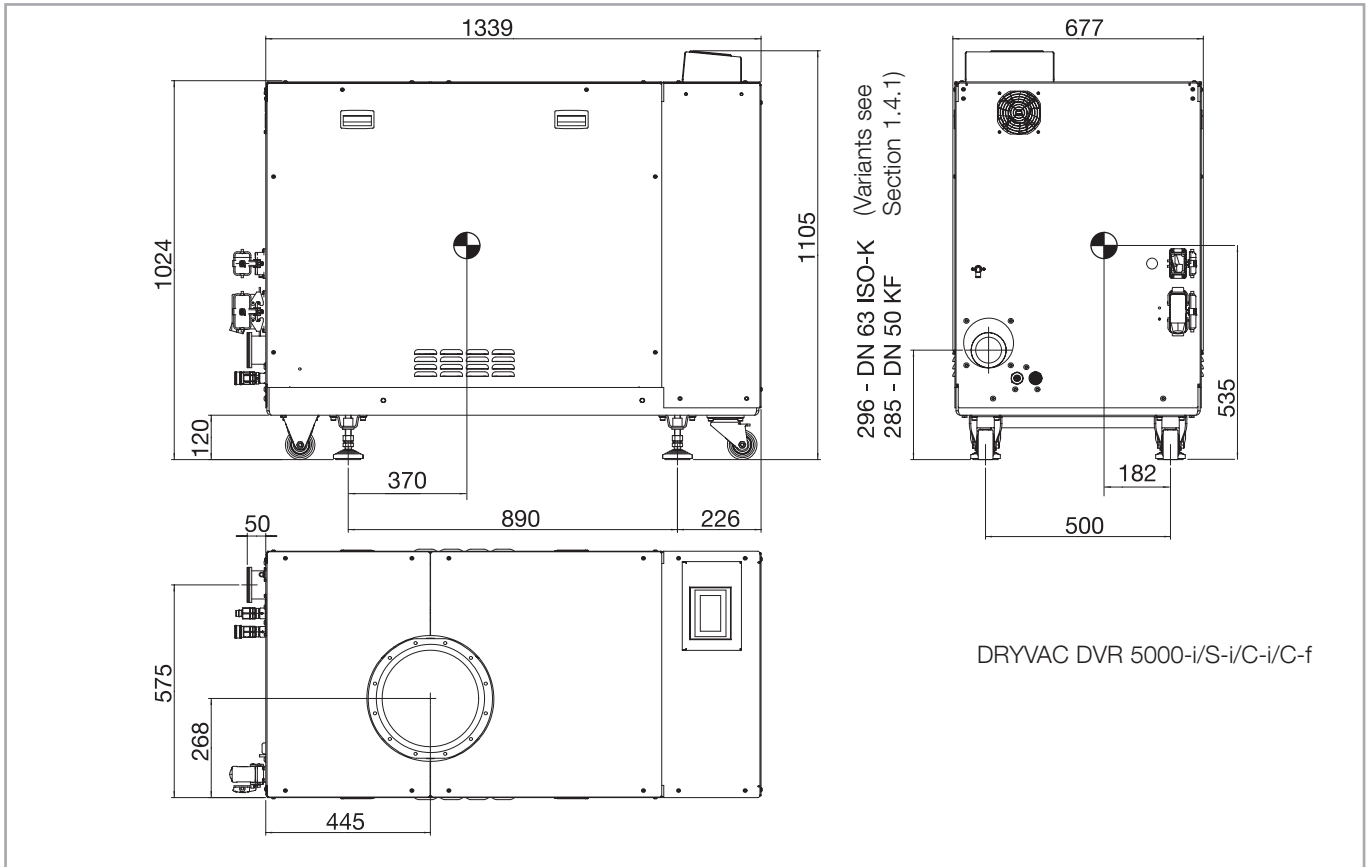

Fig. 1.8 Dimensional drawings, dimensions in mm

1.2 Supplied Equipment

- Pump as described in Sections 1.1 and 1.4.1.
- The pumps are filled with lubricant:
Synthetic oil LVO 210 **or** PFPE LEYBONOL LVO 410
- Gaskets for the oil-fill plugs for service purposes.
- The pumps are purged with nitrogen for protection against corrosion. The pump flanges have been blanked off with a sealing cap.

	DV 450 / 650	DV 1200
Crane eyes	4x M16	4x M16 (red)
for the intake flange	Intake screen with O-ring	Intake screen with O-ring

Description

1.3 Technical Data

DRYVAC	DV 450-i	DV 650-i S-i/C-i	DV 1200-i/S-i	DVR 5000-i S-i/C-i/C-f	Tolerance
Max. pumping speed w/o gas ballast	450 m ³ /h	650 m ³ /h	1 250 m ³ /h	3 800 m ³ /h	± 5 %
Ultimate total pressure w/o purge gas or with purge gas for shaft seal outlet with rotor purge	< 5 x 10 ⁻³ mbar 1 x 10 ⁻² mbar	< 5 x 10 ⁻³ mbar 1 x 10 ⁻² mbar	< 5 x 10 ⁻³ mbar 1 x 10 ⁻² mbar	< 6 x 10 ⁻⁴ mbar 1 x 10 ⁻³ mbar	± 10 %
with purge gas for shaft seal inlet (0.9 mm nozzle)	2.5 mbar	2.5 mbar	2.5 mbar	0.3 mbar	± 10 %
Maximum permissible inlet pressure	1050 mbar				
Maximum permissible discharge pressure (relative to ambient)	+200 mbar				
Integral leak rate	< 1 x 10 ⁻⁴ mbarl/s				
Water vapour tolerance with purge gas or gas ballast	60 mbar ≥ 20 NI/min	60 mbar ≥ 20 NI/min	60 mbar ≥ 40 NI/min	60 mbar ≥ 20 NI/min	
Water vapour capacity	15 kg/h	25 kg/h	50 kg/h	25 kg/h	
Permissible ambient temperature	+5 to + 40°C				
Storage temperature	-10 to + 60°C				
Contamination grade	2				
Overvoltage category	3				
Noise level with silencer, at ultimate pressure (acc. to DIN EN ISO 2151)	65 dB(A)				K _{PA} = 3dB
Noise level with rigid exhaust pipe, at ult. pressure (acc. to DIN EN ISO 2151)	65 dB(A)				K _{PA} = 3dB
Relative atmospheric humidity	95 %, non-condensing				
Installation location	up to 2,000 m (NHN) ¹⁾				
Cooling	Water/air				
Mains voltage	380–460 V ²⁾				± 10 %
Frequency	50/60 Hz				± 5 %
Phases	3-ph				
Rated power at 400 V	11 kW	15 kW	30 kW	21 kW	± 0.8 kW
Rated current at 400 V	24 A	31 A	62 A	35 A	
Power consumption at ultimate pressure	4.7 kW	6.9 kW	14 kW	9.3 kW	± 0.8 kW
Motor efficiency class, calculated and configured acc. to EN 60034-30	IE2				
Electrical power rating	13 kVA	17 kVA	34 kVA	25 kVA	
Mains fusing/characteristic	32 A/C	32 A/C	63 A/C	50 A/C	
Short-circuit interrupting capacity	< 25 kA	< 25 kA	< 50 kA	< 25 kA	
Speed Screw / Roots	7,200/min	7,200/min	7,200/min	7,200/6,000/min	
Min. permissible speed ³⁾	1,200/min				

Description

DRYVAC	DV 450-i	DV 650-i S-i/C-i	DV 1200-i/S-i	DVR 5000-i S-i/C-i/C-f	Tolerance	
Protection class	IP20					
Lubricant filling	LVO 210	LVO 210 (650-i) LVO 410 (PFPE)	LVO 210 (1200-i) LVO 410 (PFPE)	LVO 210 (5000-i) LVO 410 (PFPE)		
Total lubricant quantity	1.2 l	1.2 l	2.4 l	2.4 l	± 5 %	
Intake flange	DN 100	DN 100	DN 100	DN 250		
Discharge flange	DN 63 ISO-K	DN 63 ISO-K	DN 100 ISO-K	DN 50 KF / DN 63 ISO-K		
Materials (components in contact with gas in the pump chamber)	Grey cast iron /graphite cast iron / steel/stainless steel/epoxy paint/ fluo- rine resistant gaskets for the DVR 5000 C-f, FKM for all DV-i					
Materials sealing the pump off in the pump chamber towards the outside	FKM, grey cast iron					
Weight, approx.	790 kg	750 kg	1400 kg	1200 kg	± 40 kg	
Dimensions (L x W x H)	1339 x 677 x 681 mm		1339 x 677 x 1105 mm		± 10 mm	
Water						
Water connection	G1/2" (female)					
Water temperature pumps with synthetic oil pumps with PFPE	5 to 35 °C 5 to 25 °C					
Minimum supply pressure (unobstructed discharge, no backpressure)	2 bar(g) ⁴⁾					
Maximum supply pressure	7 bar(g) ⁴⁾					
Nominal flow	6 l/min	7.5 l/min	15 l/min	11 l/min		
Purge gas						
Connection	plug-in connection D10					
Nominal setting pressure "Purge gas" (at nominal flow, valves open)	2.8 bar(g) ⁴⁾					± 5 %
Permissible setting pressure "Purge gas" (at purge gas flow)	2.8 to 4.5 bar(g) ⁴⁾					± 5 %
Permissible supply pressure "Purge gas"	4.0 to 10.0 bar(g) ⁴⁾					± 5 %
Purge gas flow shaft seal outlet / inlet (d=0.9 mm)						
at nominal setting pressure	22 slm					
at max. setting pressure	26 slm					± 10 %
Rotor purge gas flow (nozzle d=1.0 mm)						
at nominal setting pressure	26 slm					
at max. setting pressure	33 slm					

Description

Additional information regarding the technical data

- 1) The frequency converter standard ratings are valid for an installation altitude up to 1000 m. If the altitude exceeds 1000 m both the input voltage and the rated output current must be derated for 1% per 100 m.
- 2) In case of overvoltage (> 460 V), bad cooling and permanent operation at nominal power the output power may be reduced in order to prevent thermal overload of the frequency converter.
In case of undervoltage (< 380 V) the maximum power is not available by design.
- 3) The minimum permissible speed is relevant for the oil lubrication of bearings and gears.
Running the pump at less than the minimum speed for more than 1 hour can cause damage to the pump due to a lack of lubrication.
- 4) bar(g): bar (gauge) is the overpressure, i.e. atmospheric pressure = 0 bar(g)

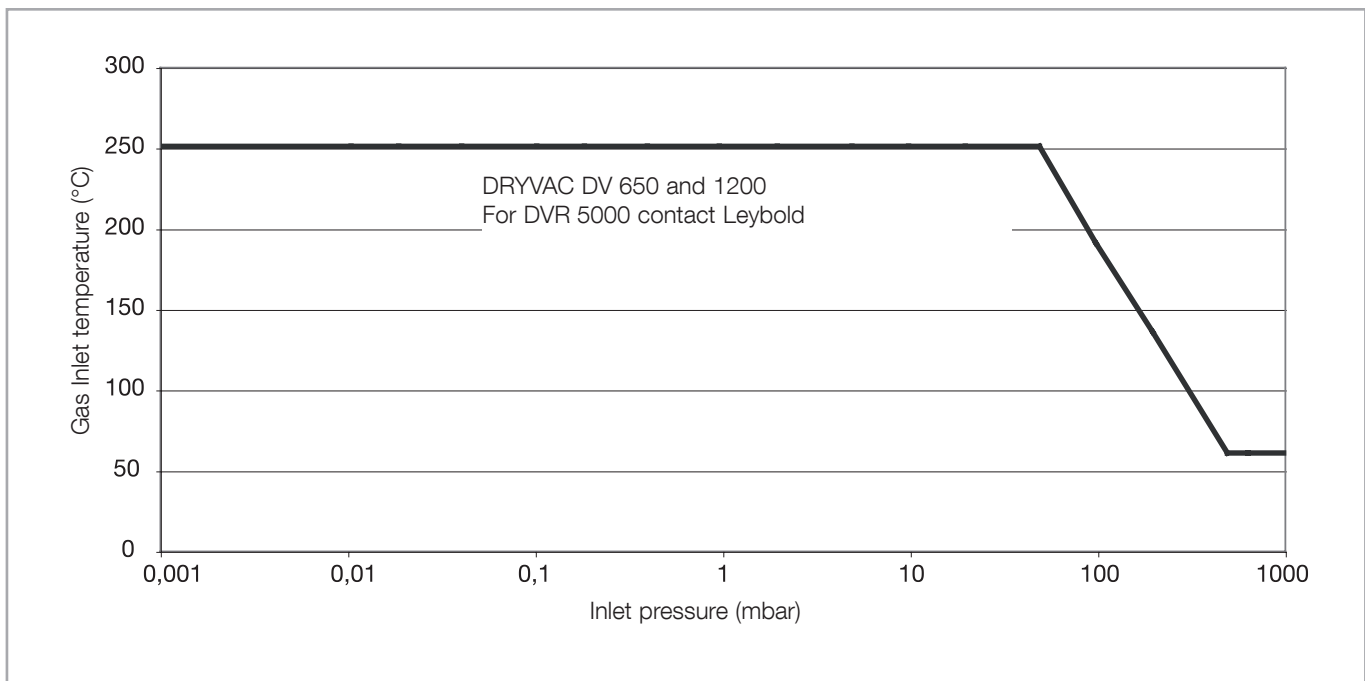

Fig. 1.9 Permissible gas inlet temperature as function of the inlet pressure

1.4 Ordering Information

1.4.1 Pumps

DRYVAC	Part No.	Lubricants (LEYBONOL)	Pump stages	Purge gas module	Enclosures / Feet	Exhaust DN
DV 450-i, 400 V	112045V50-1	LVO 210	1 screw	triple	enclosure with casters	63 ISO-K
DV 650 S-i, 400 V	112065V40-1	LVO 410	1 screw	triple	enclosure with casters	63 ISO-K
DV 650 C-i, 400 V	112065V45-1	LVO 410	1 screw	triple	enclosure with casters	63 ISO-K
DV 650-i, 400 V	112065V50-1	LVO 210	1 screw	triple	enclosure with casters	63 ISO-K
DV 1200 S-i, 400 V	112120V40-1	LVO 410	2 screws in parallel	triple	enclosure with casters	100 ISO-K
DV 1200-i, 400 V	112120V50-1	LVO 210	2 screws in parallel	triple	enclosure with casters	100 ISO-K
DVR 5000 S-i, 400 V	112500V40-1	LVO 410	2: Roots & screw	triple	enclosure with casters	63 ISO-K
DVR 5000 C-i, 400 V	112500V45-1	LVO 410	2: Roots & screw	triple	enclosure with casters	63 ISO-K
DVR 5000-i, 400 V	112500V50-1	LVO 210	2: Roots & screw	triple	enclosure with casters	63 ISO-K
DVR 5000 C-i, 400 V	112500V60-1	LVO 410	2: Roots & screw	triple	enclosure with casters	50 KF
DVR 5000 C-f, 400 V (w/ gaskets particu- larly well resistant against fluorine)	112500V61-1	LVO 410	2: Roots & screw	triple	enclosure with casters	50 KF

1.4.2 Accessories

Part No.

Synthetic oil

LEYBONOL LVO 210, 5 litres

L21005

PFPE

LEYBONOL LVO 410, 1 litre

L41001

Silencer DN 100 for DV 1200

119 001

Silencer DN 63 for DV 450/650 and 5000

119 002

Serviceable silencer DN 63 for DV 450/650 and 5000

119 003V

Serviceable silencer DN 100 for DV 1200

119 004V

Roots pump adapters for DV 450/650

for RUVAC WH 700

112 005A03

for RUVAC WS(U) 1001

112 005A04

for RUVAC WS(U) 2001

112 005A05

for RUVAC WH(U) 2500

112 005A07

for RUVAC WH(U) 4400/7000

112 005A10

Gas ballast kit DRYVAC, 24 V electropneumatically

112 005A17

Harting plug for DRYVAC S-i/RS-i

112005A20

24 Volt I/O-Kit

112 005A22

Purge gas nozzle set for DRYVAC

112 005A30

Permanent inlet purge kit

112 005A32

Crane eyes for DVR 5000 (M20x30; set of 4)

504397V901

GSD file and manual for the Profibus interface see Leybold homepage.

Transport and storage

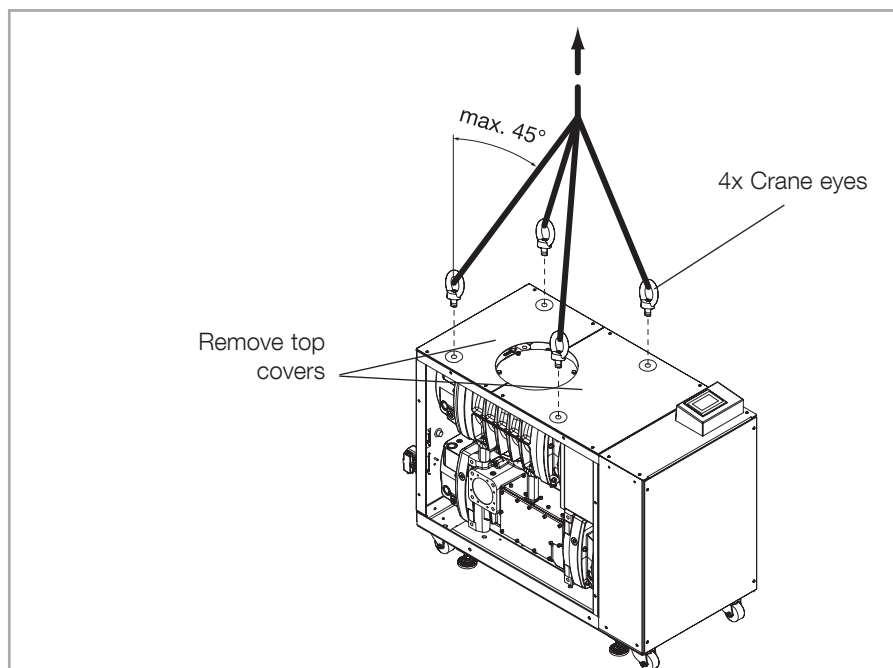

Fig. 2.1 Lifting the DRYVAC

2 Transport and Storage

WARNING



Observe safety notes 0.1.8 and 0.1.9

Crane eyes must not be interchanged with pumps! Only use the crane eyes specifically designated for the respective pump. For more information see Section "Accessories".

NOTICE



The pumps are supplied filled with PFPE or synthetic oil. For this reason they should, while being transported or shipped, not be subjected to much tilting. Store the pumps only horizontally standing on their feet.

DRYVAC DV 450, DV 650, DV 1200, DVR 5000

Unscrew 8 screws and remove the top covers. Lift the pump at the crane eyes. Use all crane eyes, see Fig. above. The pump can also be transported with a fork lift. Ensure that it cannot tip over.

Transport and storage

Pumps with castors

Due to the wheels which have been fitted, the DRYVAC must only be installed on a level surface capable of carrying the weight of the pump as otherwise there exists the danger of the pump rolling away. The pump must also only be moved on level surfaces.

Moving the pump on slopes or ramps is not allowed!

The pump must only be transported using a fork lifter or a crane.

At the installation site, use all four adjustable feet for aligning thereby securing the unit from rolling away and thus taking away the load from the castors.

Storage

Store the pump system only horizontally standing on its feet.

The pumps are purged with nitrogen for protection against corrosion and their flanges blanked off with sealing caps. Open the pumps only immediately before installing them.

If there is the danger of frost, the cooling water must be drained, see Section 4.6 Removing from Service

NOTICE



You may use a water glycol mixture of up to 30 %.

Temperature (only for storage without cooling water!) -10 °C to +60 °C

Storage site dry

Maximum atmospheric humidity 95 %, non-condensing

The pump must be stored at the most for one year only. Longer storing without turning the rotors will damage the bearings. Connect the pump to operate it briefly and then decommission it as described in the following sections. (The intake flange can stay sealed during this brief operation, the exhaust flange must be opened.)

Installation

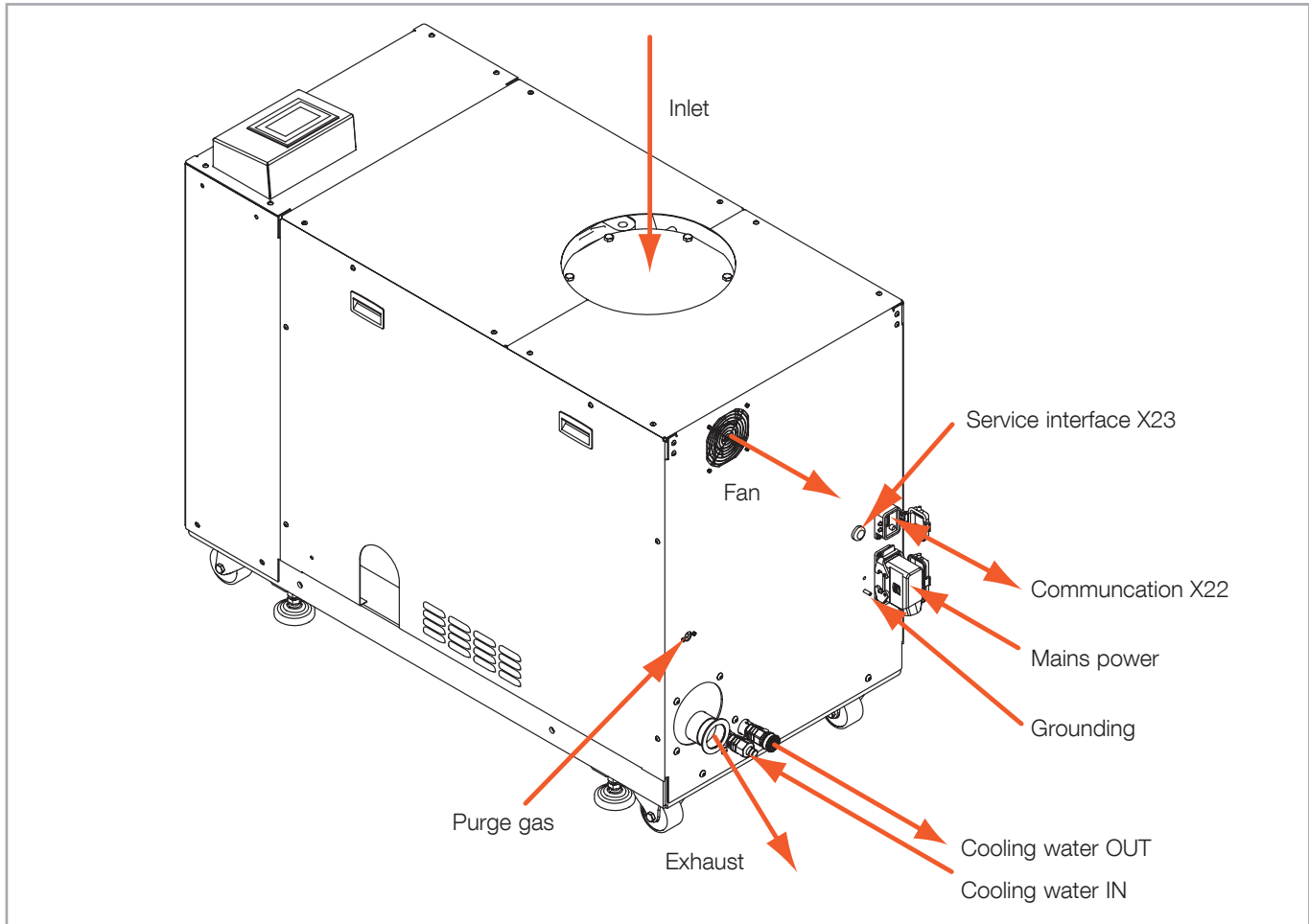

Fig. 3.1 Connections; DVR 5000 C-i drawn, other models similar

3 Installation

3.1 Placement

Place the pump system on a flat and level surface.

The pump is designed for operation in buildings.

For proper securing against rolling away, use all four adjustable feet for aligning thus taking away the load from the castors.

Remove covers and blank flanges on the pump just before fitting the pump so that the assembly work can be performed under the cleanest conditions.

Check whether there is any desiccant present in the intake area. If required remove it.

Do not block the fan's cooling air flow.

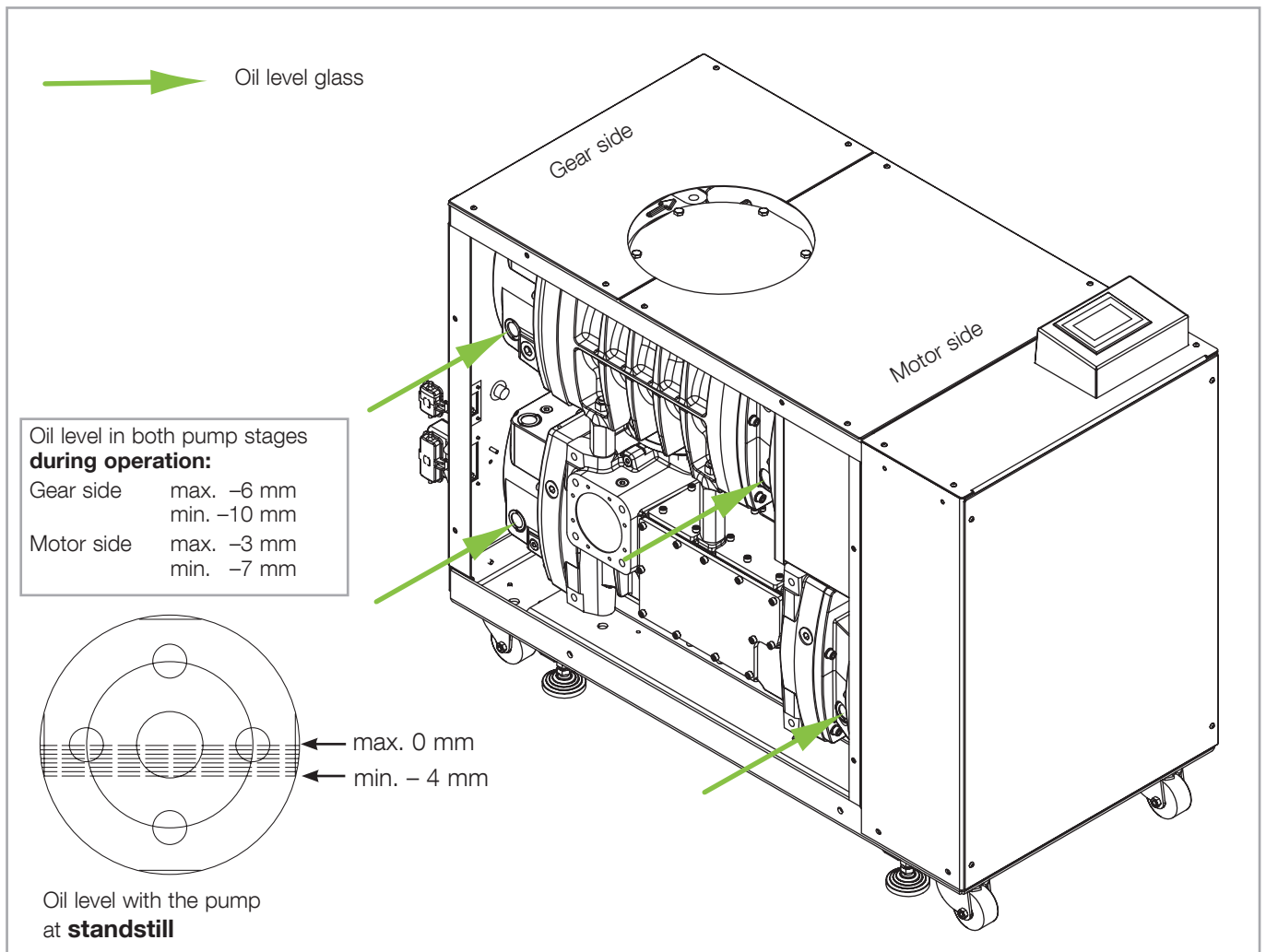

Fig. 3.2 Oil level in the DRYVAC oil glasses

The pumps are supplied filled with synthetic oil or PFPE. Nothing will have to be refilled. Check the oil levels through all oil level glasses (2 per pumping stage).

If one of the oil levels is found to be incorrect, please contact us.

3.2 Conforming Use

The DRYVAC dry pumps have been developed to meet the demanding requirements for process pumping solutions in the Coating, Flat panel, Process and Solar industries.

Basically, all DRYVAC pumps are leaktight and may for this reason be utilised for pumping toxic and potentially flammable gases outside their ignition range. For such applications, note the safety information given in Section 0.4. When using the pumps in connection with oxidising or corrosive gases, check media compatibility first. Media compatibility and the therefrom resulting hazards of each substance used and also of each substance mixture need to be reassessed on a case-by-case basis.

There are different product variants (see Section 1.4.1) for different application focuses.

DRYVAC pumps delivered with synthetic oil (hydrocarbons) have a limited application scope. When assessing media compatibility here, in particular the hazards resulting from the reaction of the process gases with the hydrocarbons must be assessed. For this read the information given in the Safety Booklet and/or consult us for details.

DRYVAC C and S pumps delivered with PFPE offer a higher level of media compatibility.

DRYVAC C-i pumps are process pumps suited also for operation with much oxidising and corrosive media. With these pumps, you may pump both toxic and potentially flammable gases outside their ignition range and a large number of corrosive and much oxidising substances and substance mixtures.

DRYVAC S-i pumps are load lock, transfer and process pumps for clean or medium rough processes. Their deployment in combination with some much oxidising media is not recommended.

In the case of increased **fluorine** concentrations only DVR 5000 C-f pumps may be used.

When planning to pump hazardous substances always consult Leybold first.

3.2.1 Non-conforming Use

Non-conforming use for the pump are among others:

- Operation with limit parameters which are not programmed by Leybold, particularly the maximum speed.
- Pumping of gases and vapours for which the materials of the pump are not suited, consult Leybold. For a list of materials in contact with the process gases, see Section 1.3 Technical Data.
- Pumping of substances and mixtures (gases, liquids and solids) which are rated as being explosive.
- Pumping of condensable vapours without adequately controlling the temperature of the pump. Upon compression in the pump, these vapours may condense or form deposits, consult Leybold.
- Pumping of dusts and solids without suitable screens and filters, consult Leybold.

- Pumping of liquids
- Pumping of ignitable gas mixtures
- Pumping of process gases which form hard or sticky deposits which may cause the pump to seize.
- The use of pump and frequency converter in the explosion hazard areas
- Non-compliance with the described maintenance and service intervals.
- Use in systems and pump systems in which the exhaust pressure may increase over 1.2 bar abs.
- Operation with an inadequately affixed pump.
- Operation at impermissibly high gas temperatures
- Use in systems where pump, frequency converter and cables are subjected to impact stresses.
- Operation on movable systems or system components (locks or mobile pump systems).
- Use of pump, fitted ad-on components, drive electronics, flanges and cables to climb onto the system.
- Removing, covering or obstructing warning notices.
- Operation outside of buildings.
- Standstill or storing of pump and drive electronics without suitable sealing and drying. When stored in a humid atmosphere corrosion can occur.
- Conversions, manipulations and maintenance work by persons not authorised by Leybold.
- Accessories which have not been specified by Leybold may only be used after approval by Leybold.
- In the condition as delivered, the DRYVAC DVR 5000 C-i pumps are not suitable for sustaining regular atmospheric pressure bursts as they may occur in the course of load lock operation, for example. When planning such an application please consult us first.

The non-conforming use of pump and accessories may result in severe injury or damage to the components.

WARNING

Installation

3.2.2 Pumping 100% Argon

- Working pressure > 80 mbar is permissible for max. 5 minutes (30 minutes recovery afterwards), or at a reduced speed of 70 Hz without time limit.
- DV450: Constant working pressure between 1 and 100 mbar is possible. DV650 & 1200: Constant working pressure between 1 and 80 mbar is possible
- Working pressure < 1 mbar and for longer than 5 minutes is only possible at 70 Hz operation or with N₂ purge.
- Argon is not permitted as purge gas.
- Provide 20 slm N₂ or clean dry air as purge gas at the exhaust.

3.3 Connecting the Intake and Exhaust Lines

3.3.1 Connecting Bellows

We recommend to connect the pumps with bellows and vibration absorbers



Align the bellows. Do not overstress the bellows. Too much stress on the bellows will cause premature failing of the bellows and thus leaks in the system.

- The bellows may only be fitted and commissioned by trained installation personnel. Proper and professional mounting is an absolute requirement for safe and reliable operation!
- Before mounting the bellows check these as to possible shipping or storage damage in particular regarding damaged surfaces. Also the valleys between the ridges of the bellows - inside and outside - must be free of any substances or materials.
- The connecting pipes must align as precisely as possible. If possible readjust the lines at their supports.
- If the bellows are equipped with fixed flanges, then their screw holes must align with the screw holes on the piping. The bellows must not be subjected to torsion stress.
- The amount of expansion must not exceed the specified amount of axial expansion/compression or the stated amount of side displacement. A combination of axial expansion/compression and side displacement is possible. The total percentage of the partial expansions must be less than 100%. For this refer to Fig 3.3.

Examples: **DN 100:** the amount of side displacement is 4 mm. This corresponds to 42% of the permitted side displacement of 9.5 mm. In this case a maximum of 58% of the permitted axial displacement is possible: 16 mm.

DN 250: the amount of axial displacement is 15 mm. This corresponds to 50% of the permitted axial displacement of 30 mm. In this case then a maximum of 50% of the permitted side displacement is possible: 2.2 mm.

- When using movable pump systems connected to fixed piping, position the pump system as precisely as possible and then reliably secure it in place.
- When mounting the bellows make sure that no tensions from the side of the pipe can have a torsional effect on the bellows.
- When lifting equipment is used to mount the bellows, then such equipment must not be attached to sensitive sections like the actual bellows section itself.

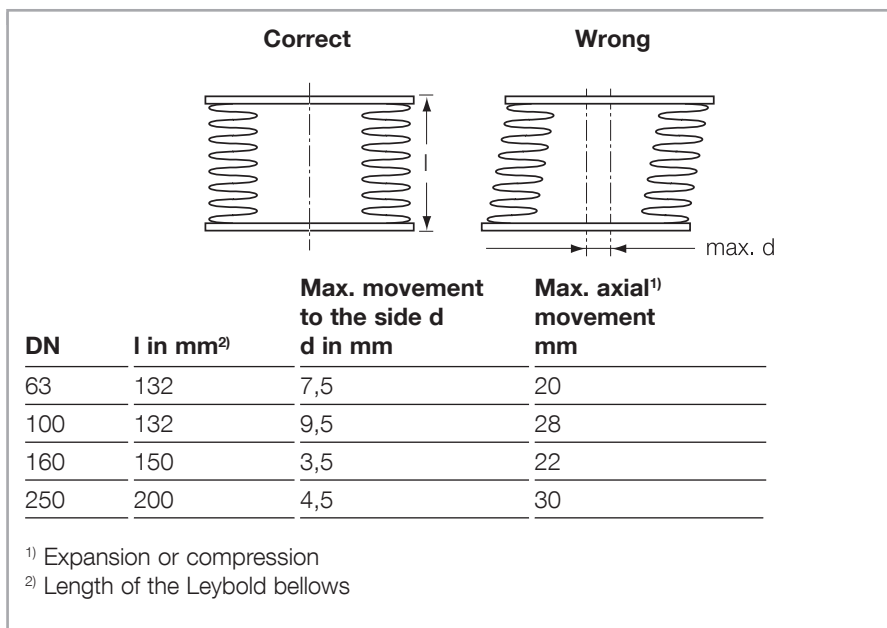

Fig. 3.3 Maximum movement of the bellows

- Run the pressure and leak search on the system only after the bellows have been properly mounted. The bellows shall be installed so that an unrestricted visual inspection regarding integrity is possible in regular inter-

Installation

vals.

- In the case of deficiencies like indentations, cracks, corrosion, discolouration or irregular deformations, replace the bellows.
- Insulation must only be attached to the bellows after prior consultation.
- Avoid pressure bursts in the system.

3.3.2 Intake Lines

Connect the intake lines to the system. The bellows on the top of the pump system are only connection elements and intended for vibration absorption. They are not suited to carry the load of intake lines.

Support the intake lines.



Align the bellows. Do not overstress the bellows. Too much stress on the bellows will cause premature failing of the bellows and thus leaks in the system.

The intake lines must be clean.



Ensure that no items like **welding beads**, bolts, nuts, washers, pieces of wire, for example, enter into the inlet. Observe Safety Information 0.8.3.

Connect the intake flange: Either with intake screen and O-ring or with a centering ring without outer ring.

3.3.3 Exhaust Lines

Always operate the pump with a connected exhaust line. The exhaust line must be designed for the specific kind of application. Lay permanent piping to the outside or connect it to a suitable exhaust gas abatement system.

Abatement system

Connect the exhaust line to an abatement system with sufficient throughput, if required by the process. The DRYVAC pumps will be switched off because of overpressure if the abatement system is too small.

Connect the exhaust lines to the pump system's exhaust connections. Use

bellows to eliminate tension in the line.

The exhaust line should have the same or larger diameter than the exhaust flange and 2.0 mm min. thickness.

The exhaust line must be able to withstand 1.3 bar and 150 °C.

Keep the exhaust line free of deposits. If the exhaust flow becomes restricted, deposits could collect in the DRYVACs.

Avoid connecting the pump system together with oil-sealed pumps to one central exhaust system. Using a common exhaust line could result in condensate back streaming into the DRYVAC or in dust adhering in the exhaust line.

In the case of wet processes avoid the ingress of any liquid into the pump. Observe Safety Information 0.8.10, 12, 14.

Connect the exhaust line to an abatement system with sufficient throughput, if required by the process. The DRYVAC pumps will be switched off because of overpressure if the abatement system is too small.

In order to prevent deposits in the exhaust lines it may be necessary to heat the exhaust lines.

Run the exhaust line only by way of a fixed installation to the outside and/or connected to a silencer.

Check leak tightness of the exhaust lines on a regular basis!
Observe Safety Information 0.4.

If your installation requires a housing extraction consult with Leybold.

NOTICE



DANGER



extraction line

CAUTION



3.4 Connecting Cooling Water

Observe Safety Information 0.3.3 to 0.3.6.

Connect the cooling water and ensure that the cooling water discharge is not constricted in any way.

Select the lines in view of the temperatures and pressures which are to be expected. Select a nominal width which is as wide as possible so as to avoid pressure losses especially for the discharge (flow velocity below 2 m/s).

The temperature of the discharged cooling water must not exceed 55 °C as otherwise the lines will tend to calcify.

Ensure an adequate cooling water flow in accordance with the technical data.

Cooling water data for the pump

Materials in the cooling circuit of the pump AISI 304, red brass, brass, EPDM, epoxy paint,

Feed temperature
 pumps with synthetic oil 5 °C – 35 °C
 pumps with PFPE 5 °C – 25 °C

Feed pressure 2 – 7 bar (g)

Type	Power loss to be dissipated by the cooling water kW	Cooling water demand at feed temperature (assuming a constant discharge temp. of 55 °C)			
		30°C...35°C	25°C...30°C	20°C...25°C	<20°C
		l/min	l/min	l/min	l/min
DV 450	7	6.0	4.8	4.0	3.5
DV 650	10.5	7.5	6.0	5.0	4.3
DV 1200	21	15.0	12.0	10.0	8.6
DVR 5000	15.5	11.1	8.9	7.4	6.3

The DRYVAC pumps are equipped with a built-in pressure reducer. We recommend not to change the setting.

A screen has been built into the pressure reducer protecting the valve seat-against coarse contamination, see also Section 5.4 Maintenance.

The gauge only serves the purpose of checking the pressure reducer, see Section 5.4.1.

The DRYVAC pumps are equipped with a pressure relief valve. It prevents the water from boiling in the cooling circuit when the cooling water supply and drain are closed. The valve opens at 8 bar(g) and releases small amounts of water or vapour into the base pan.

If work on the water cooling system becomes necessary and in the case of a longer standstill or transportation, completely drain out all cooling water and completely dry the lines (with nitrogen, for example).

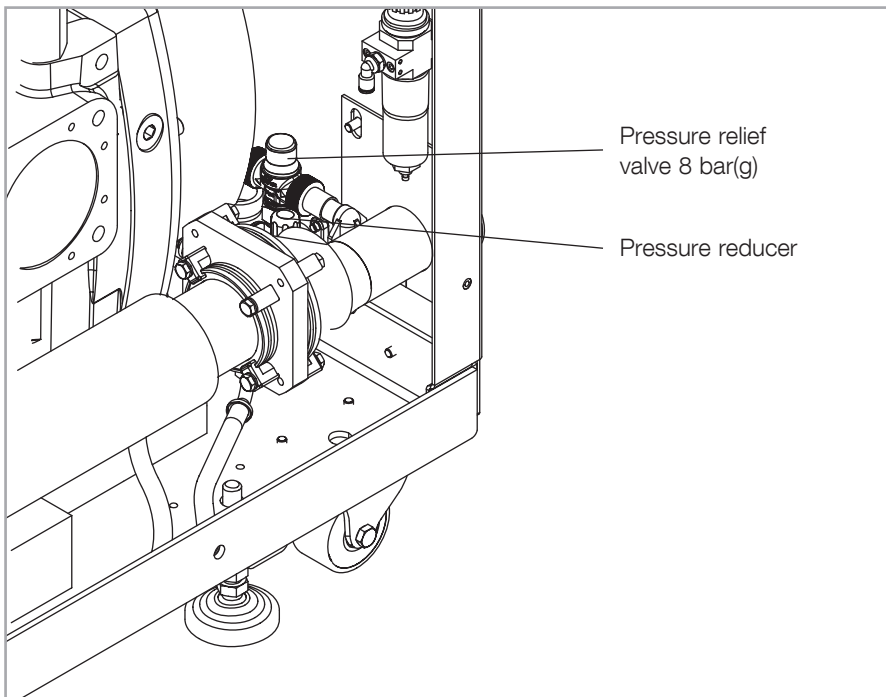

Fig. 3.4 Water pressure reducer

Block or label the area of the cooling water and exhaust lines to prevent tripping.

Installation

3.4.1 Water Quality

In order to ensure long trouble-free operation the cooling water must not contain any oils, greases and suspended solids. Moreover, we recommend compliance with the following limit values:

Appearance	Clear, free of oils and greases
Suspended matter	< 250 mg/l
Particle size	< 150 µm
Electrical conductivity	< 700 µS/cm
pH value	7.0 to 9.0
Total hardness (total alkaline earths)	< 8 °dH
Aggressive carbon dioxide	None, not detectable
Chloride	< 100 mg/l
Sulfate	< 150 mg/l
Nitrate	≤ 50 mg/l
Iron	< 0.2 mg/l
Manganese	< 0.1 mg/l
Ammonium	< 1.0 mg/l
Free chlorine	< 0.2 mg/l

8 °dH (degrees German hardness) = 1.4mmol/l
= 10 °e (degrees English hardness)
= 14 °f (degrees French hardness)

If there is the danger of frost, you may use a water glycol mixture of up to 30 %.

DS water can be used for cooling the pump, if the pH value corresponds to the range indicated above.

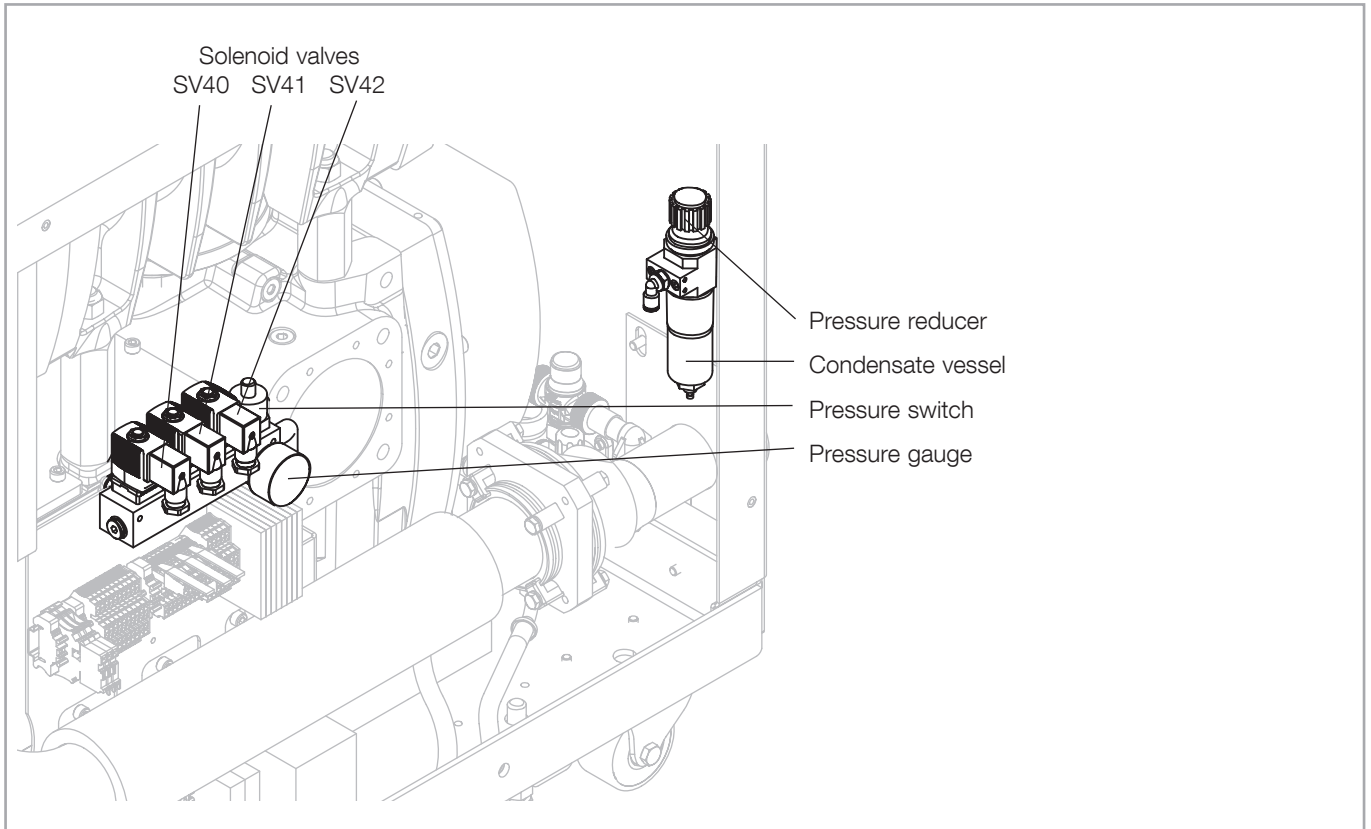

Fig. 3.5 Purge gas module

3.5 Connecting Purge Gas

There are two versions of the purge gas module:

- At the triple purge gas module the gear chamber seals right and left of the pumping chamber are protected with purge gas. The third gas inlet inserts the purge gas directly into the pumping chamber (rotor purge).
- At the single purge gas module only the gas inlet for the protection of the motor gear is connected. The second purge gas connection and the rotor purge are blank flanged.

The manifold block with valves, gauge and condensate separator is identical for both versions.

Connect dry nitrogen or any other suitable dry gas as purge gas, depending on your process. Check process compatibility.

Gas temperature	0 to +50°C.
Filter size	40 µm
Max. condensate capacity	22 cm ³

The pump system must only be vented such that **atmospheric pressure is never exceeded.**

Ensure that the gas flow is not obstructed.

The purge gas supply should not be shut off while the pump system is operating, above all especially not during shutdown and venting operations.

Installation

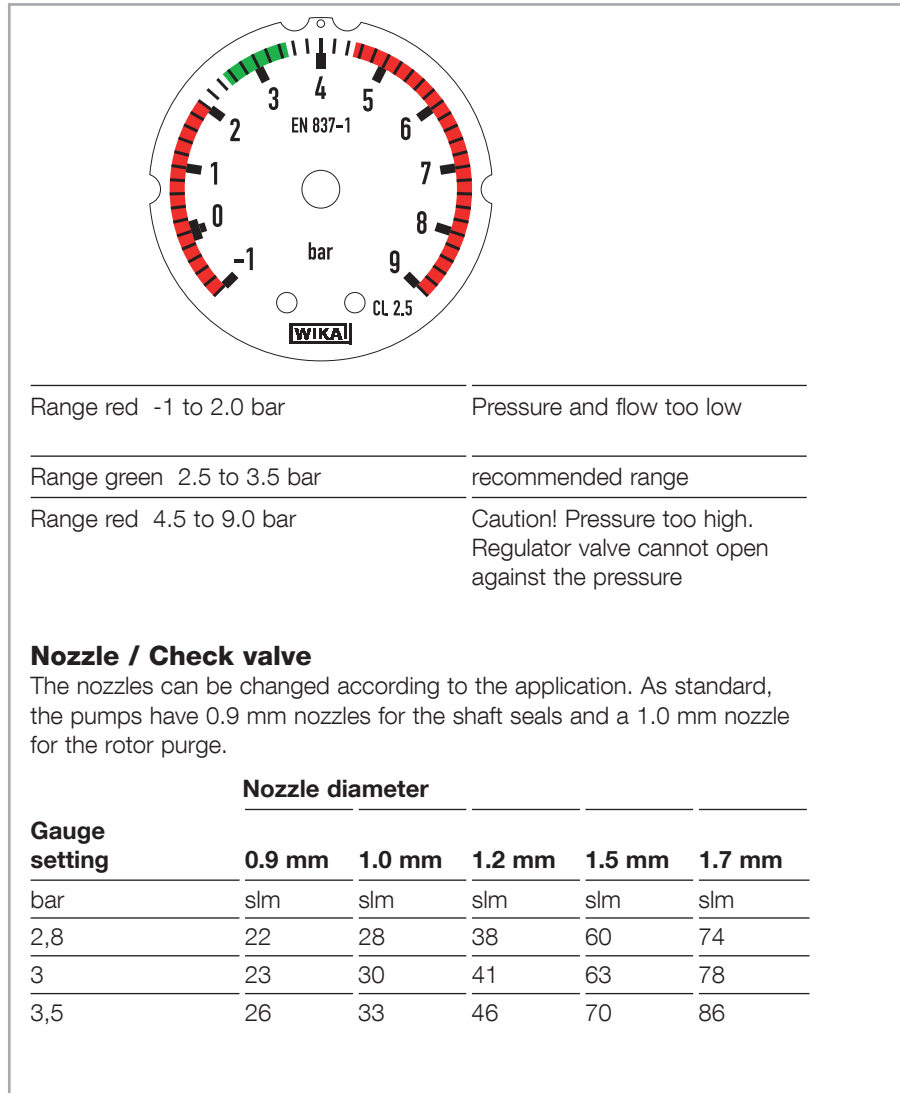

Fig. 3.6 Details for the purge gas module

Wetted materials: Brass, aluminium, zinc, polycarbonate, polybuteneter-phthalate (PBT), NBR, polyamid-Tube, copper, stainless steel, PTFE, Loctite.

The purge gas supply pressure is set to 2.8 bar at nominal flow (valves open) on delivery.

To adjust, pull the adjustment knob to the top. Inherent to its functional principle, the pressure with closed valves is always higher than with flow. A pressure loss of up to 0.5 bar can be expected. I.e. if the pressure is set to 2.5 bar with closed valves, the pressure switch may signal a fault. In this case set the pressure moderately higher.

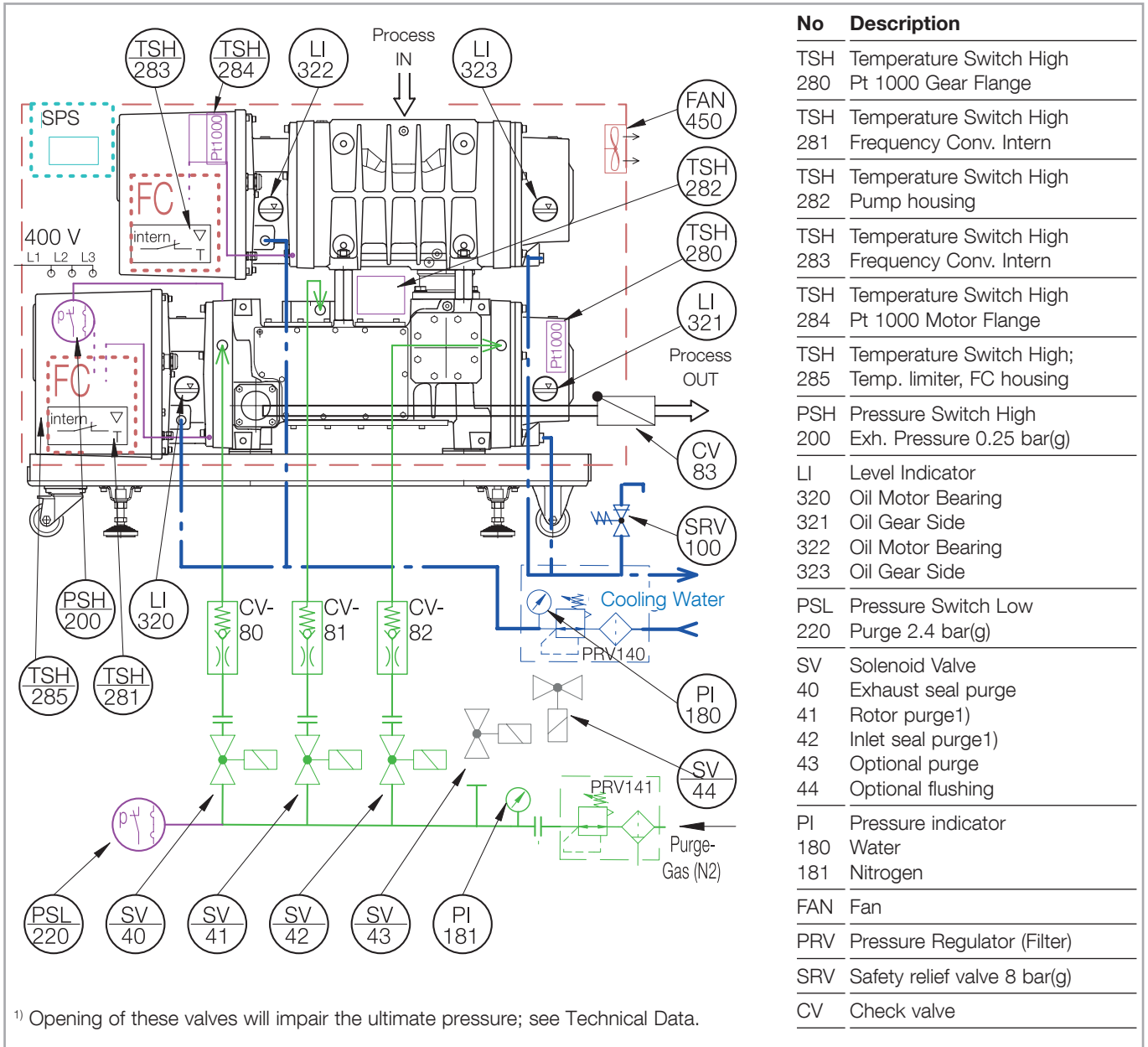

Fig. 3.7 Purge gas and switches schematic for the DVR 5000

Installation

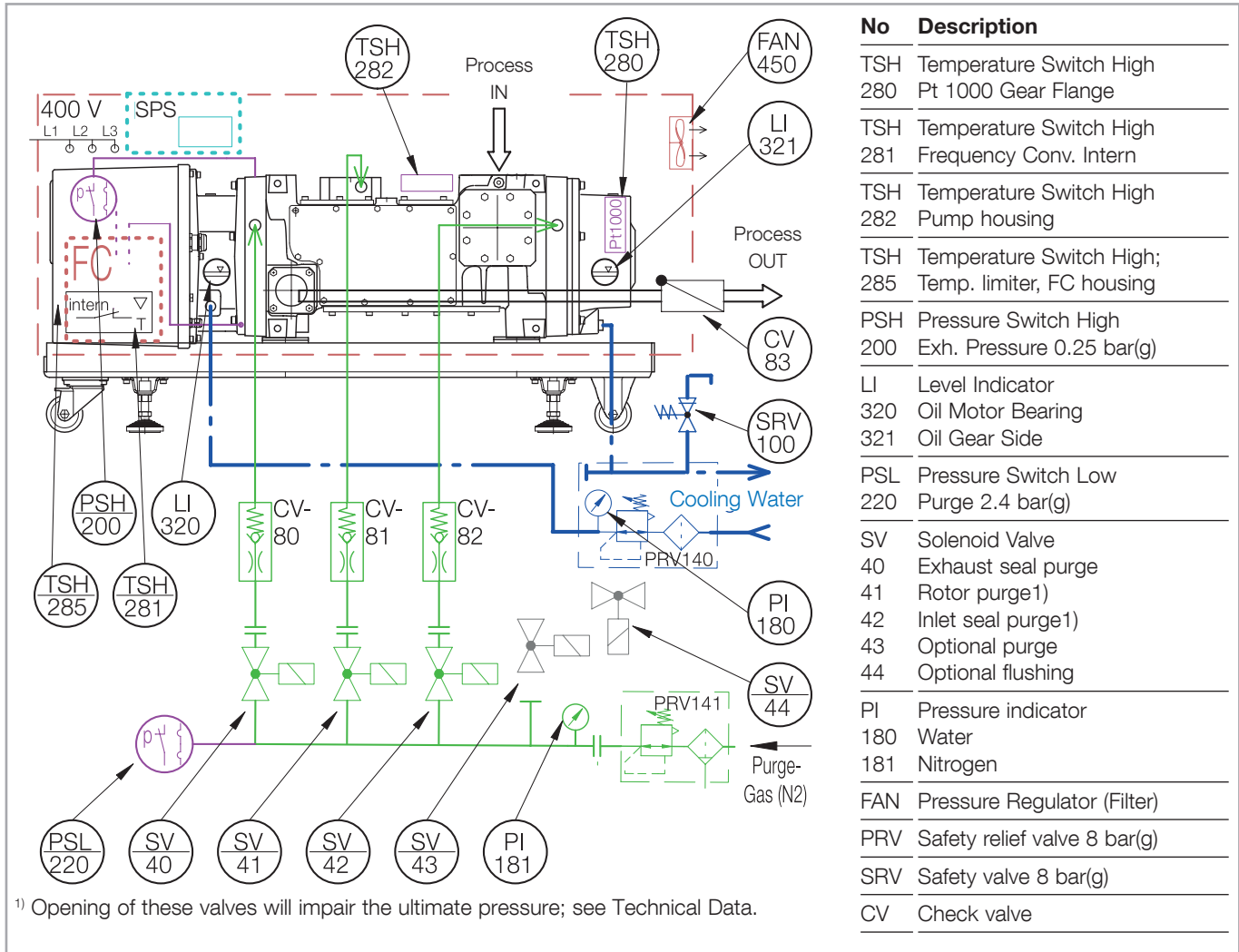

Fig. 3.8 Purge gas and switches schematic for the DV 650

3.5.1 Guidelines for Purge Gas Operation, Settings and Monitoring

NOTICE



Possible purge gases are N₂ and CDA only.

The safety always has to be considered (please be careful with air purges and read the safety booklet of Leybold).

Exhaust shaft seal purge is running in most of all applications all the time.

Rotor purge

- In most cases not used all the time, often active in specific process steps.
- Used for light gas performance, dilution to avoid condensation, dilution to reduce chemical reaction and dilution to dilute below flammability limits.
- Applying up to 33 slm purge gas (1.0 mm nozzle) to the rotor purge position on DV450 and on DV650 results in: $p_{\text{end}} < 1 \times 10^{-2}$ mbar for air or N₂.

Exhaust shaft seal purge

The exhaust shaft seal purge is the most important purge position of the pump to protect the pump from process materials and to keep it dry and clean. The exhaust shaft seal purge protects the motor area (piston ring shaft seal, bearings, motor) against particles / dust and condensable gases like water or others. This purge is always recommended and there are only a few applications possible where one can stop exhaust shaft seal purge flow.

Gas types: Air (consider safety concerning flammable gases), Nitrogen.

- Exhaust shaft seal purge is running in 99% of all applications at all time.
- Open exhaust shaft seal purge when starting the pump and stop it after the pump has stopped.
- In many cases it might be better to keep the exhaust shaft seal purge on for 15 – 30 min after stopping the pump – this cleans and dries out the exhaust.
- If you want to operate without exhaust shaft seal purge please contact Leybold technical support.
- The exhaust purge gas does not reduce the pump performance in any way.

Inlet shaft seal purge

- The process industry pumps (all pumps which have LVO210 as lubricant) are equipped with a 2.0 mm nozzle – this provides ~ 90 slm of gas flow (up to 80 slm on the DV1200).

If there is a risk, that in the application condensable gases or solids can be transported into the gearbox area, it is a must to use inlet side venting purge to protect the DRYVAC pump.

NOTICE



a) Contamination during pump down or fast pressure rise

- For fast pressure rises the 2.0 mm nozzle has to be used on the inlet side.
- Activate flow (solenoid valve) 2 seconds before pressure rise.
- Stop flow when the inlet pressure drops below 100 mbar.
- If you have only the 0.9 mm nozzle installed (2.0 mm recommended) activate flow 2 seconds before pump down and stop the flow when the pressure drops below 20 mbar.

b) Contamination during chamber vent

- To avoid contamination during chamber venting, the inlet purge should be activated at all time during the chamber venting.

Installation

c) Contamination during continuous operation

- Use the 2.0 mm nozzle in combination with the solenoid valve (customer controlled) to protect against fast pressure rises.
- Use the smaller nozzle to allow a continuous flow of gas at all time (constant flow).
- If a constant flow is not possible you can try to control the small flow (0.9 mm nozzle) as well, i.e. with pressure rises and ventilation.

With the **accessory “Permanent Inlet Purge Kit”**, the inlet side of the DRYVAC pump may be protected against being contaminated. This is effected by a permanent, comparatively small purge flow (0.5 SLM). For this, the Permanent Inlet Purge Kit is so connected that it is always opened when also the purge gas on the exhaust side (motor side) of the pump is open; i.e. generally always when the DRYVAC being switched on.

Pressure switch: To monitor purge gas availability

The shut-off threshold of the pressure switch PSL220 is 2.4 bar(g). This switch (cf. fig. 3.5) is located in between pressure regulator and the solenoid valves. This switch is always installed, but the signal is not controlled by the pump itself (frequency converter). An LED indicates the status on the device itself. A to be connected PLC or junction box is needed to monitor this signal.

3.6 Electrical Connection

DANGER



Observe Safety Information 0.2.

Danger of electric shock or sparking!

Plug or unplug the Harting mains connectors only when no voltage is present.

Wiring the Main Circuit Input

Consider the following precautions for the main circuit input.

- Use fuses recommended in Main Circuit only, see technical data. Do not use a motor protection switch.
- If using a ground fault circuit breaker, make sure that it can detect both DC and high frequency current.

Connector-Mains / Supply - Type for up to 60/63A (Fusing):

The mains plug is not included in the scope of delivery, but is available as an accessory; cf. Section 1.4.

Maker: Harting Type: Han K4/2 Ord.No.: 09 38 006 2701 Female insert, 4pole+PE, Type: Han (16B) Ord.No.: 19 30 016 0528 Connector housing for M40 cable fitting (or equivalent type)

The system must only be operated off a three-phase mains power supply of 380 - 460 V AC, 50/60 Hz with PE- conductor.

Pin 1 = L1 (R), Pin 2 = L2 (S), Pin 3 = L3 (T), PE-Terminal = PE (Earth).
Neutral (N) must not be used.

Ground Connection

Take the following precautions when grounding the frequency converter.

- Always connect the frequency converter to ground in accordance with the international and local regulations for equipment exhibiting an increased leakage current.
- Keep the ground wires as short as possible. **The frequency converter produces leakage currents** (typically less than 10 mA). In the case of unbalanced mains power supplies, the leakage current may exceed 10 mA. In this case the protective ground conductor must exhibit a cross-section of at least 10 mm². Or connect a further protective ground conductor having at least the same cross-section as the connection cable. A connection point is provided.
- When using more than one frequency converter, do not loop the ground wire.
- For compliance with IEC 61010-1 it is mandatory to connect the additional protective earth conductor.

Establishing Potential Equalisation

An M 6 thread is provided at the pump housing for connecting the external potential equalisation cable.

Connect the potential equalisation conductor as depicted in Fig. 3.9.

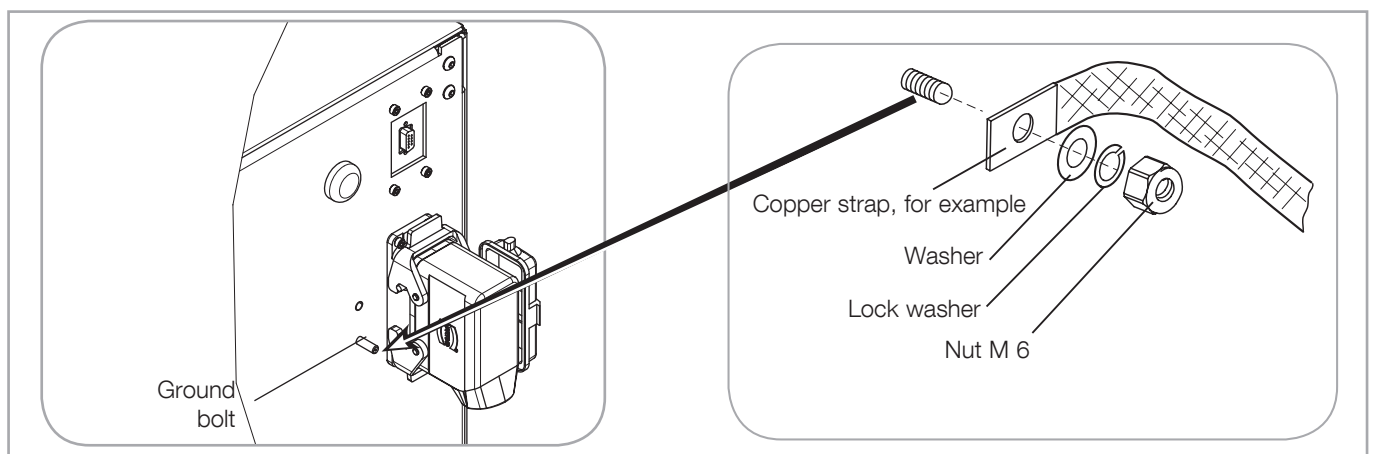

Fig. 3.9 Establishing the potential equalisation at the pump casing

Installation

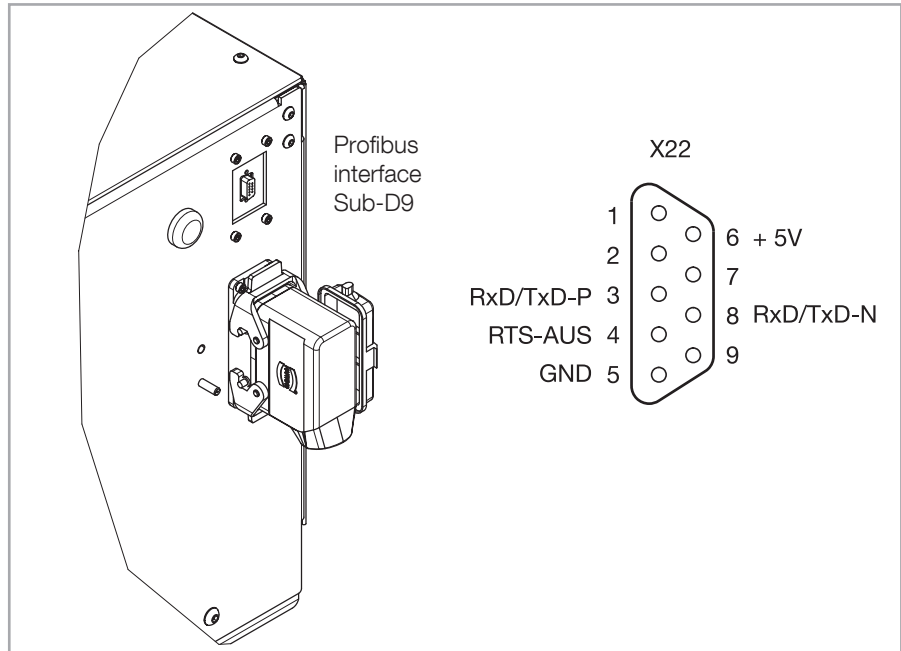

Fig. 3.10 Profibus interface

Profibus interface

See Fig. 3.10 and Section 4.2. Further information on request.

24 V interface

A 24 V interface is optionally available. Please ask us for information.

Notes Relating to Electromagnetic Compatibility (EMC)

By maintaining the operational conditions specified this product complies with the EMC emission limits for industrial production environments.

NOTICE



The frequency converter may, when deployed in residential areas, cause high-frequency interference. In such a case the operator of the unit will have to introduce additional measures for the purpose of suppressing high-frequency interferences.

DANGER



3.7 Leak Search after Installation

Observe Safety Information 0.4.

On delivery, the pump is leak tight to 10^{-4} mbar·l/s (integral, leak-checked). Leak-check all relevant connections after having installed the pump.

4 Operation

Observe Safety Information 0.6.



4.1 Media Compatibility

See Section 3.2 Conforming Use. For a list of materials in contact with the process gas, see Section 1.3 Technical Data.

In the case of increased **fluorine** concentrations only DVR 5000 C-f pumps may be used.

If you use the system on an application for which it is not suitable, you may invalidate your warranties. If in doubt, contact Leybold.

4.2 Profibus Interface for i-Version

GSD file

The GSD file and the manual can be downloaded from www.leybold.com/ -> Documents -> Download Software. The GSD file for the i-versions is different from the GSD file for the DRYVAC versions without integrated control. Do not mix them up.

Technical data

Voltage supply	24 VDC \pm 10 %
Current consumption	approx. 90 mA
2 Status LEDs for Profibus, 1 Status LED for CAN status	
Max. transmission width between PROFIBUS and PLM	configurable
Input	16 Words/256 Bits
Output	16 Words/256 Bits

Operation

Profibus DP

The DRYVAC is a slave unit and thus responds to requests from the master, and supplies data exclusively after having received a request to do so from the master.

At both ends of the bus a terminating resistor is required. Such a terminator must be incorporated in an external plug. The connections for this plug are provided through the interface connector. For this also see the standards.

Profibus DP V0 corresponding to IEC 61158-2 and IEC 61784 Type 3.

Transmission rates and cable lengths

(see also the standards)

Transmission rate (kBit/s)	max. segment length (m)
9.6–93.75	1200
187.5	1000
500	400
1500	200
3000–12000	100

The **baud rate** is set automatically. The following baud rates are supported:

9.6 k Baud	19.2 k Baud	45.45 k Baud	
93.75 k Baud	187.5 k Baud	500 k Baud	
1.5 M Baud	3 M Baud	6 M Baud	12 M Baud

Connection

The default Profibus address is 40 dec. This address may be changed through the menu displayed through the touch panel of the pump.

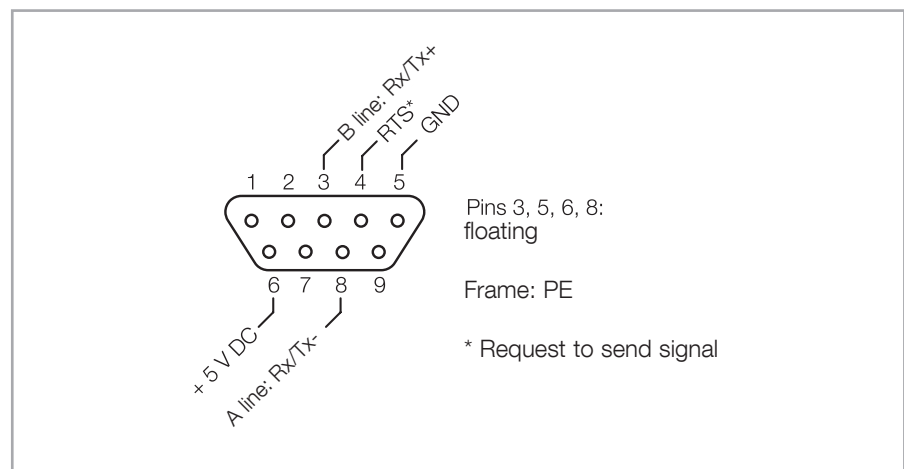

Fig. 4.1 Pin assignment for the socket

Operation

Status word (from DRYVAC)

Lower pump setpoint f	Lower pump FC temp.	Lower pump actual value I	Lower pump actual value f		Housing temperature	Lower pump temperature	Upper pump temperature							Operating mode	System status
15	14	13	12	11	10	9	8	7	6	5	4	3	2	1	0
0000 1100	0000 0000	0000 0000	0000 0000	0000 0000	0000 0000	0000 0000	0000 0000	0000 0000	0000 0000	0000 0000	0000 0000	0000 0000	0000 0000	0000 0100	0000 0000
7		6		5		4		3		2		1		0	

Word

Bit 15 Bit 0

Lower pump error code		Upper pump error code				Error bits 2	Error bits 1		Valve status	Upper pump status	Lower pump status	Upper pump setpoint f	Upper pump FC temp.	Upper pump actual value I	Upper pump actual value f
31	30	29	28	27	26	25	24	23	22	21	20	19	18	17	16
0000 0000	0000 0000	0000 0000	0000 0000	0000 0000	0000 0000	0000 0000	0000 0000	0000 0000	0000 0001	0000 0000	0000 0000	0000 0000	0000 0000	0000 0000	0000 0000
15		14		13		12		11		10		9		8	

Fig. 4.3 Status word

Lower Pump = Screw (DV 650); Screw (DV 1200); Screw (DV 5000)

Upper Pump = - (DV 650); Screw (DV 1200); Roots (DV 5000)

Simple version: status word

Word	Byte	Designation	Details
0	0	System status	Bit 0 Ready for operation Bit 1 Run-up Bit 2 Rundown Bit 3 Normal operation attained Bit 4 Purge error Bit 5 Purge warning Bit 6 Remote active Bit Life Toggle Bit
	1	Operating mode	0000 0000 = 0 = Mode A 0000 0001 = 1 = Mode B 0000 0010 = 2 = Mode C
4	8	Lower pump temperature	
	9	Upper pump temperature	
5	10	Housing temperature	
6	12	Lower pump actual frequency	
	13	Lower pump actual current	
7	14	Lower FC temperature	
	15	Lower pump setpoint frequency	
8	16	Upper pump actual frequency	
	17	Upper pump actual current	
9	18	Upper FC temperature	
	19	Upper pump setpoint frequency	
10	20	Lower pump status	
	21	Upper pump status	
11	22	Valve status	Bit 0 SV40 open Bit 1 SV41 open Bit 2 SV42 open

12	24	Error bits1	Bit 0 Upper pump error Bit 1 Lower pump error Bit 2 Purge error Bit 3 Upper pump no maximum freq. Bit 4 Lower pump no maximum freq. Bit 5 Lower pump communication error Bit 6 Upper pump communication error Bit 7 Purge warning
	25	Error bits2	Bit 8 Housing temperature warning Bit 9 Housing temperature error Bit 10 Profibus communication error
14	28 29	Upper pump error code	
15	30 31	Lower pump error code	

Examples for units of measurement

Temperature 0001 0111 = 17 hex = 23 °C
 Frequency 0111 1000 = 78 hex = 120 Hz
 Current 1010 1010 = AA hex = 170 = 17.0 A

Comprehensive version: control word

Word	Byte	Designation	Details
0	0	System control	Bit 0 Start/stop Bit 5 Enable pump 1 setpoint Bit 6 Enable pump 2 setpoint Bit 7 Reset error
	1		Bit 8 Define operating mode Bit 10 Control rights/PB remote (change from 0 to 1) Bit 11 Enable valve control
1	2	Valve control	Bit 0 Switch SV40 on Bit 1 Switch SV41 on Bit 2 Switch SV42 on
2	4	Pump 1 control	Bit 0 Pump start/stop Bit 7 Reset
5	10	Pump 1 define setpoint freq.	0 – 255 Hz Roots max. = 100 Hz; Screw max. = 120 Hz
7	14	Pump 2 control	Bit 0 Pump start/stop Bit 7 Reset
10	20	Pump 2 define setpoint freq.	0 – 255 Hz Roots max. = 100 Hz; Screw max. = 120 Hz
11	23	Operating mode selection	0000 0000 = 0 = Mode A 0000 0001 = 1 = Mode B 0000 0010 = 2 = Mode C

Status word (from DRYVAC)

Lower pump status		Housing temperature	Upper pump actual value l	Upper pump actual value f	Upper pump setpoint f	Upper pump FC temp.	Upper pump temperature	Upper pump error code		Upper pump status		Valve status		System status	
15	14	13	12	11	10	9	8	7	6	5	4	3	2	1	0
0000 1100	0000 0000	0000 0000	0000 0000	0000 0000	0000 0000	0000 0000	0000 0000	0000 0000	0000 0000	0000 1100	0000 0000	0000 0000	0000 0001	0000 0100	0000 0000
7		6		5		4		3		2		1		0	

Bit 15 Bit 0

								Operating mode	Lower pump actual value l	Lower pump actual value f	Lower pump setpoint f	Lower pump FC temp.	Lower pump temperature	Lower pump error code																	
31	30	29	28	27	26	25	24	23	22	21	20	19	18	17	16																
0000 0000	0000 0000	0000 0000	0000 0000	0000 0000	0000 0000	0000 0000	0000 0000	0000 0000	0000 0000	0000 0000	0000 0000	0000 0000	0000 0000	0000 0000	0000 0000																
15				14				13				12				11				10				9				8			

Fig. 4.5 Status word

Comprehensive version: status word

Word	Byte	Designation	Details
0	0	System status	Bit 0 Ready for operation
	1		Bit 1 Status Bit 3 Error Bit 4 Run-up Bit 6 Rundown Bit 7 Warning
1	2	Valve status	Bit 10 Normal operation attained Bit 14 Warning
	4		Bit 0 SV40 open Bit 1 SV41 open Bit 2 SV42 open
2	4	Upper pump status	Bit 0 Ready for operation Bit 3 Error Bit 4 Acceleration Bit 5 Deceleration
	5		Bit 10 Normal operation attained Bit 11 Pump is turning Bit 14 Warning
3	6	Upper pump error code	
4	8	Upper pump temperature	
	9	Upper FC temperature	
5	10	Upper pump setpoint frequency	
	11	Upper pump actual frequency	
6	12	Upper pump actual current	
	13	Housing temperature	
7	14	Lower pump status	Bit 0 Ready for operation Bit 3 Error Bit 4 Acceleration Bit 5 Deceleration
	15		Bit 10 Normal operation attained Bit 11 Pump is turning Bit 14 Warning

Operation

8	16	Lower pump error code	
	17		
9	18	Lower pump temperature	
	19	Lower FC temperature	
10	20	Lower pump setpoint frequency	
	21	Lower pump actual frequency	
11	22	Lower pump actual current	
	23	Operating mode	0000 0000 = 0 = Mode A 0000 0001 = 1 = Mode B 0000 0010 = 2 = Mode C 0000 0111 = 7 = Remote

Example for units of measurement

Temperature 0001 0111 = 17 hex = 23 °C

Frequency 0111 1000 = 78 hex = 120 Hz

Current 1010 1010 = AA hex = 170 = 17.0 A

4.3 Start-up

Checks before every Start-up

Check if the pump system is leak tight.

Close all protective covers.

Open the exhaust lines.

Open the purge gas supply if connected.

Open the cooling water return and supply.

Switch on the main switches.

Check messages on the touchscreen or on the frequency converter display.

Setting the Display Language

For changing the display language press SETTINGS in the main screen and then on Sprache or Language.

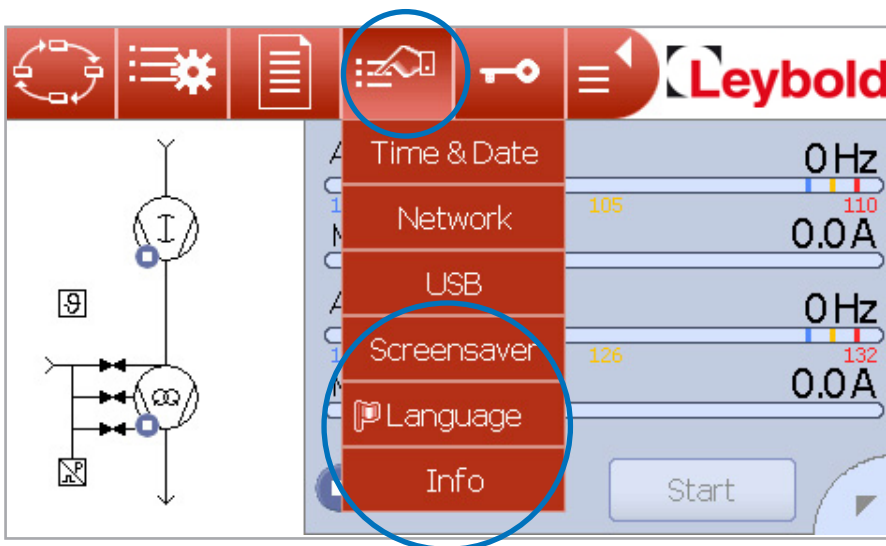

Fig. 4.6 Main screen

Operation

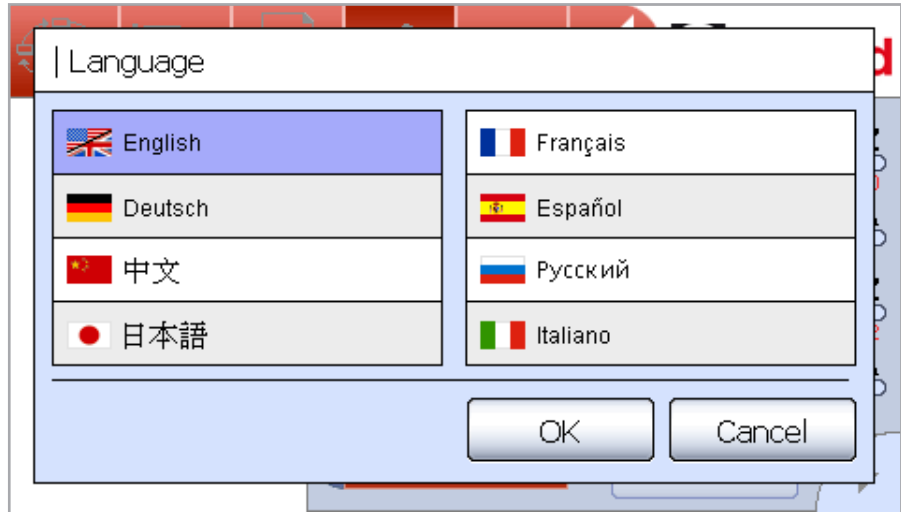

Fig. 4.7 Language selection

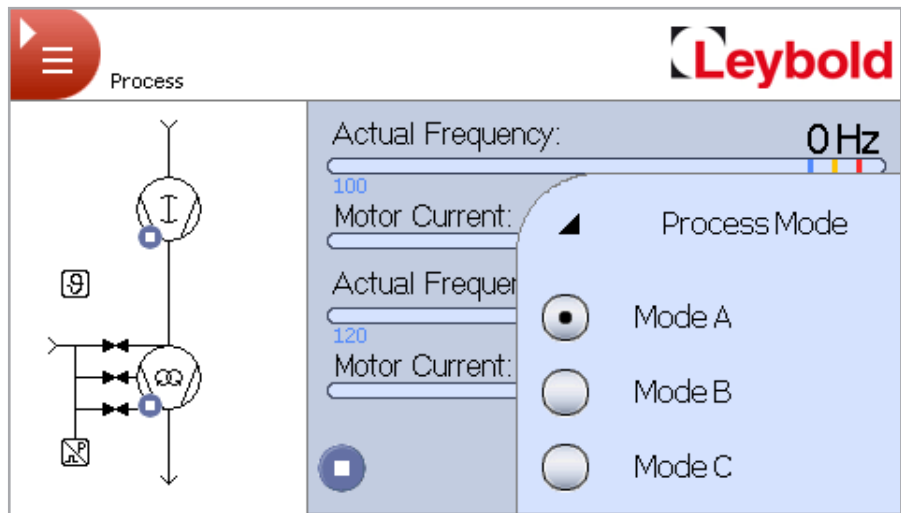

Fig. 4.8 Before start-up

DANGER



Starting the Pump

In processes, where the process gases or by-products react with air, purge the pump with nitrogen at every start-up before opening it to the process. This reduces the risk of reactions (like explosions) when the process gases come into contact with remaining oxygen in the pump.

Start the pump through the remote control or the touchscreen. It is ready for operation after 5 minutes.

Dry the pump, if required by the process. To do so turn on the pumping system and run it at ultimate vacuum for a period 60 minutes with a dry nitrogen shaft seal purge before opening it to the process.

Hot surfaces, risk of suffering burns.
Notice safety information 0.3.

CAUTION

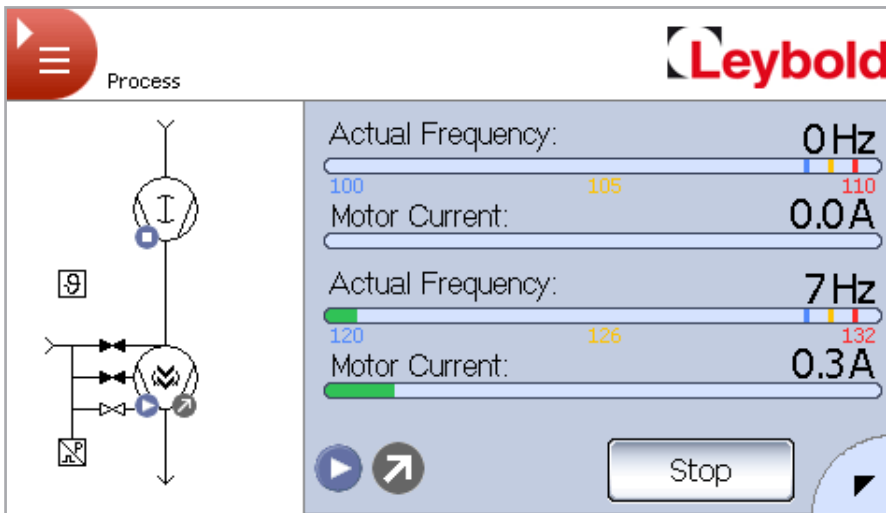

Fig. 4.9 Screw stage runs up

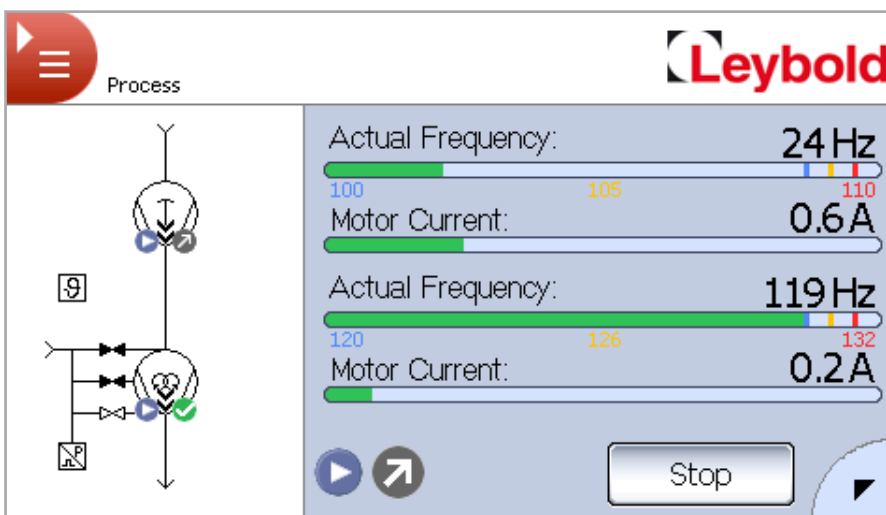

Fig. 4.10 Screw stage ready, Roots stage runs up

The run-up is shown on the display. The following displays are for the 2-stage DRYVAC, the displays for the single stage DRYVAC are similar, just without the Roots pump symbols. The current values are examples.

At the DRYVAC DVR 5000 the screw pump runs up. After the screw pump has reached 90 % of the max. speed, the Roots pump starts up and accelerates to its nominal speed.

Operation

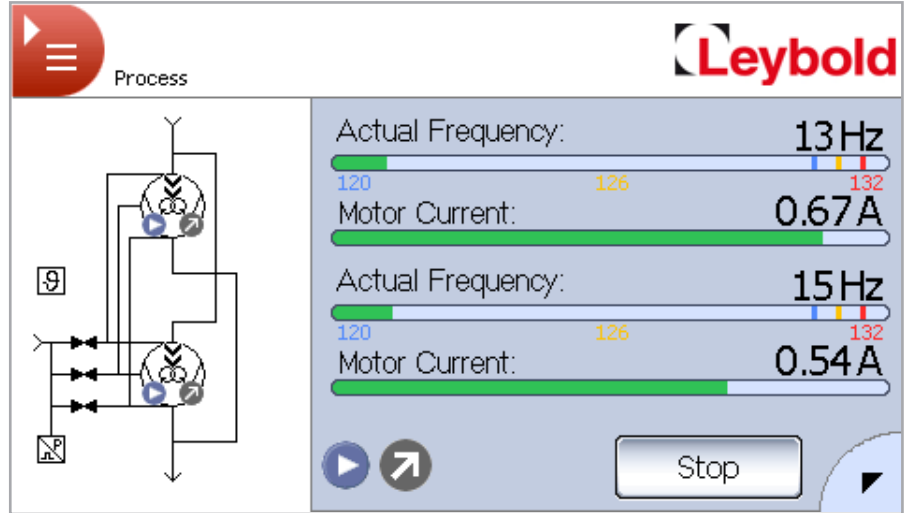

Fig. 4.11 DRYVAC DV 1200 runs up

In the case of the DRYVAC DV 1200, the controller ensures that both pump stages will be operated simultaneously. Should one of the two pump stages fail due to a malfunction, then the other pump stage is also automatically shutdown.

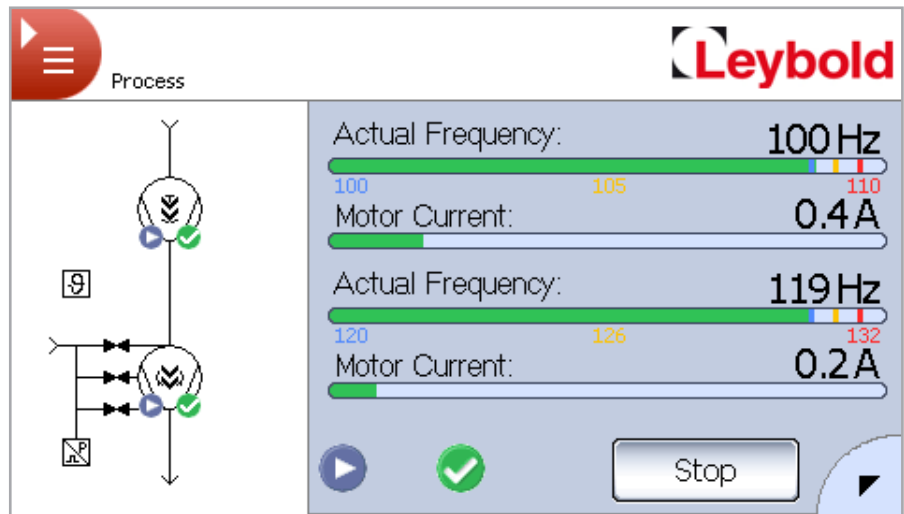

Fig. 4.12 DRYVAC DVR 5000 ready for operation

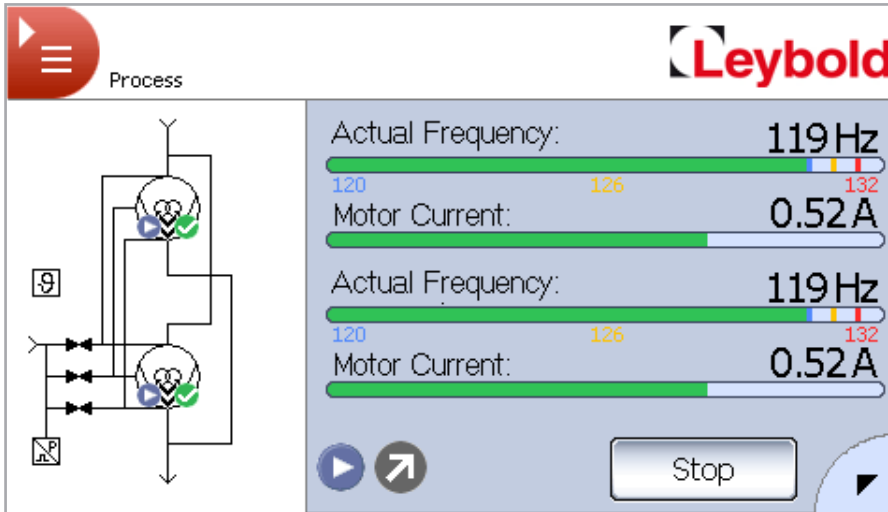

Fig. 4.13 DRYVAC DV 1200 ready for operation

4.3.1 The Display Icons

- | | | | |
|---|--|---|---------------------|
|  | Speed is reducing/process is shutting down |  | Roots pump |
|  | Speed is increasing/process is running up |  | Screw pump |
|  | Warning/warning threshold has been reached |  | Pump is running |
|  | Stop command is pending. Stop button was operated |  | Fault |
|  | Pump/process was started (Start command is present) |  | Communication fault |
|  | Valve is open, gas flow is possible | | |
|  | Valve is closed, no gas flow is possible | | |
|  | Process " Ready" has been reached, normal equipment status | | |
|  | Pressure sensor | | |
|  | Vacuum gauge head | | |

Operation

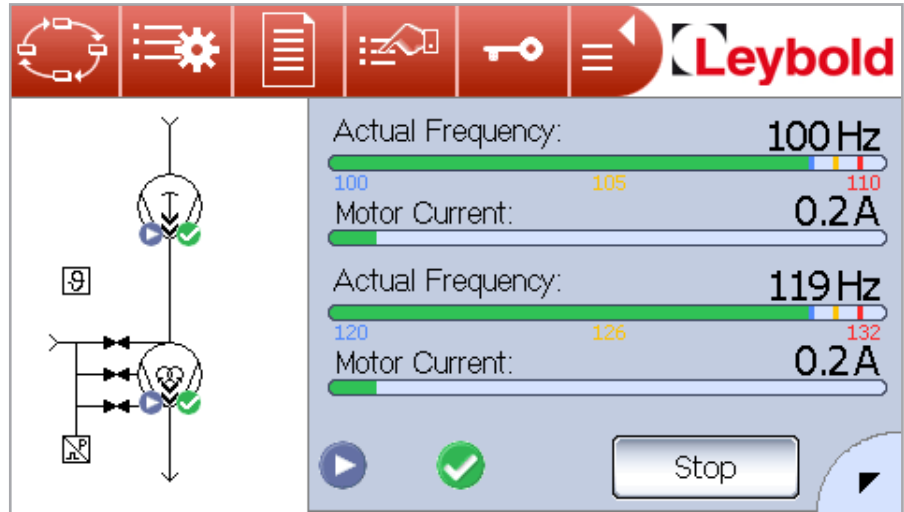

Fig. 4.14 Main screen

4.4 Operation

The pumps are operated either via remote control or the touch screen. On the remote control unit the start or stop buttons are dimmed and when pressed there will be no response.





4.4.1 Display Menu Items

From the toolbar at the top of the display you can select between 5 menu items and their submenus.

The main menu items are (from left to right):

PROCESS CONFIGURATION LISTS SETTINGS PASSWORD

The corresponding submenu items are:

	PROCESS	Process Logging Temperatures Pump data
	CONFIGURATION	Process Wizard Service mode
	LISTS	Alarm/warning
	SETTINGS	Time & Date Network USB Screensaver Language Info
	PASSWORD	Password level entry

While on the left-hand side of the display the process status is schematically displayed, you can read off on the right hand display side the specific values and set up any parameters.

For this click on the corresponding main menu and submenu items.

Explained in the following are the details and adjustment options for the individual menu items, some menu items are not available at the moment.

In the submenu item "Process" it is possible to change pump settings.

4.4.2 Password handling

Some of the functions activated from the main menu are saved by a password level. This level needs to be entered before the functions are available:

Without entering any password level it is possible to Start and Stop the vacuum process. It will not be allowed to change any settings for "Process" operation or enter the "Servicemode". "Wizard" cannot be accessed at the DRYVAC.

To activate the Password level input, press the key icon.

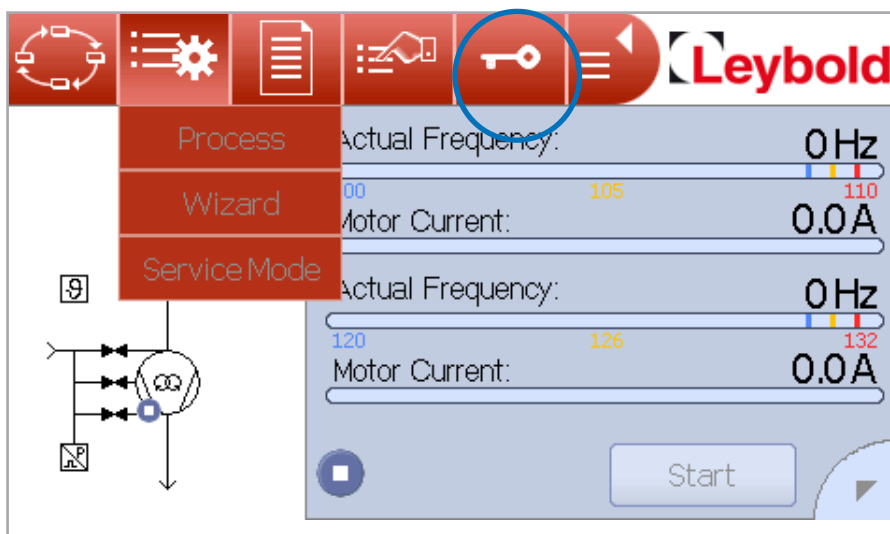

Fig. 4.15 Password input

The up coming window shows the actual User Level (0 = no login)

Operation



Fig. 4.16 Password input

For new login level press “Log-in” button. You will get into the enter mode to activate the new level:

“customizing” is the password for level 1 (the password is fixed at the moment) to activate all functions of the touchscreen. The level 1 password can be deactivated while pressing the “Log-out” button or switch OFF the mains supply.

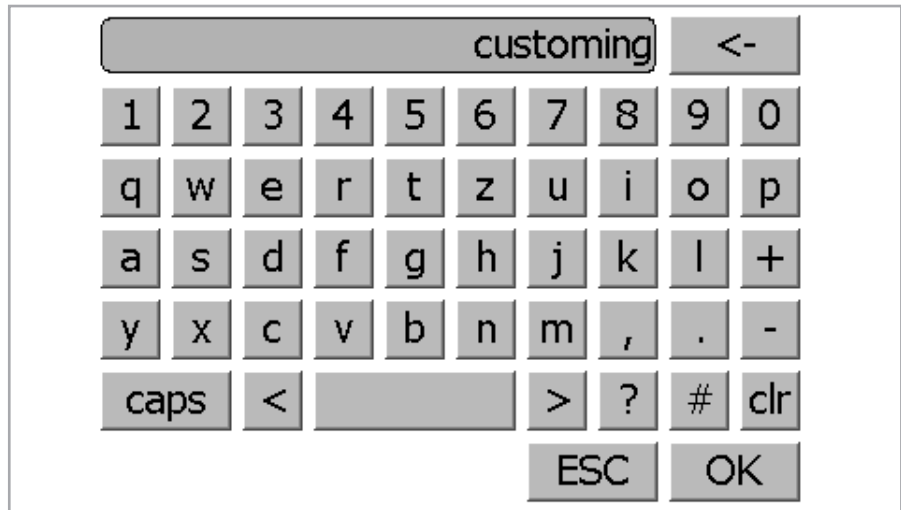

Fig. 4.17 Password input

4.4.3 Setting Pump Configurations

Under Configuration pressing on Process and then on Setpoints opens a menu for setting up the pump and valve configuration.

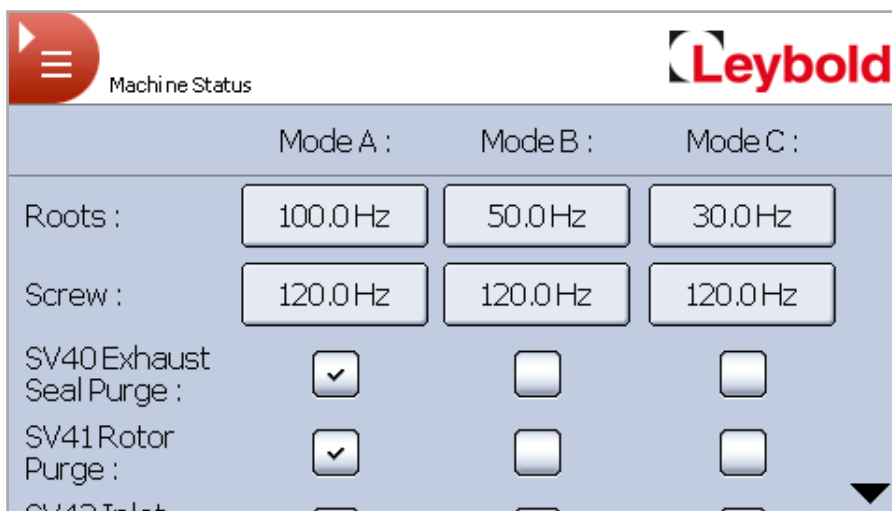

Fig. 4.18 Machine status

Under Configuration pressing on Process and then on Designer opens a menu for setting up the valves for certain operating conditions.

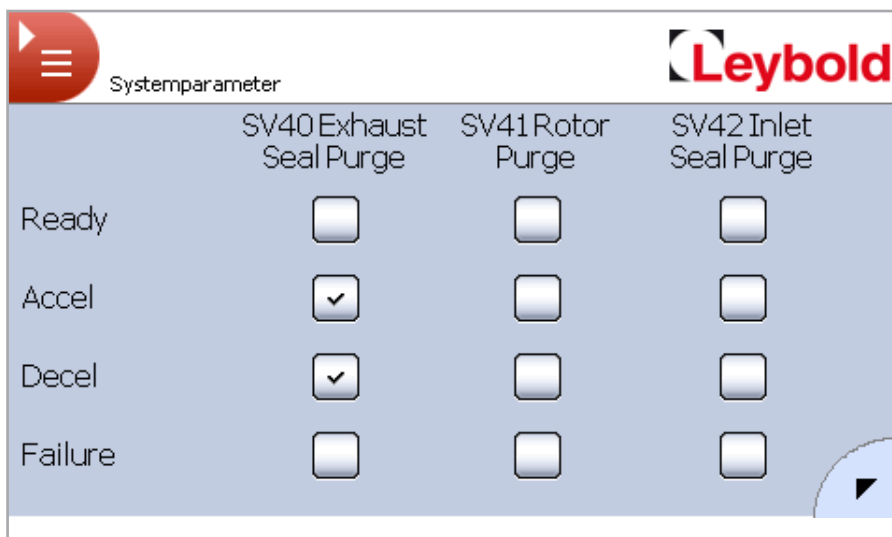

Fig. 4.19 System parameters

We recommend to consult with Leybold which pump configuration is sensible and permissible for your process. Wrong configurations, which may damage the pump, will nullify the warranty.

NOTICE



Pressing on the arrow at the bottom on the right-hand side and then on Limits displays the warning and error limits.

Operation

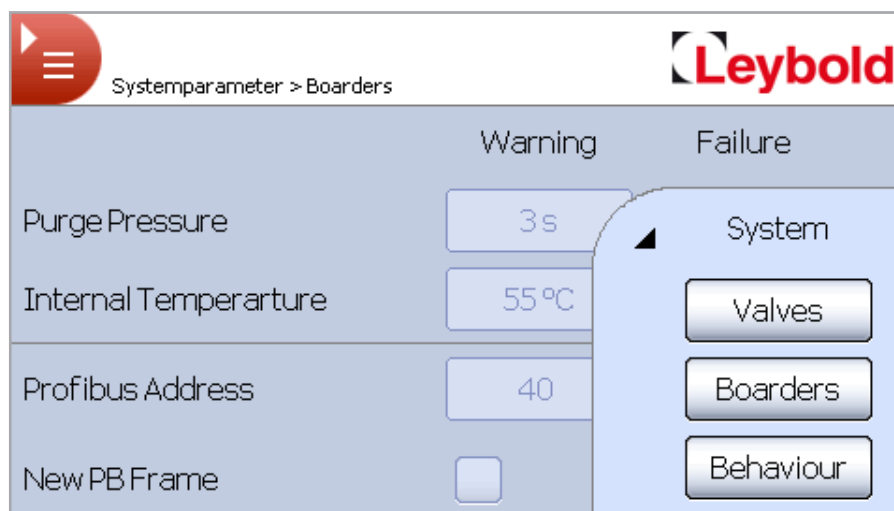

Fig. 4.20 System parameters limits

Moreover here the Profibus address can be entered (default = 40) and a new, detailed Profibus telegram can be selected, for telegram descriptions see Section 4.2.

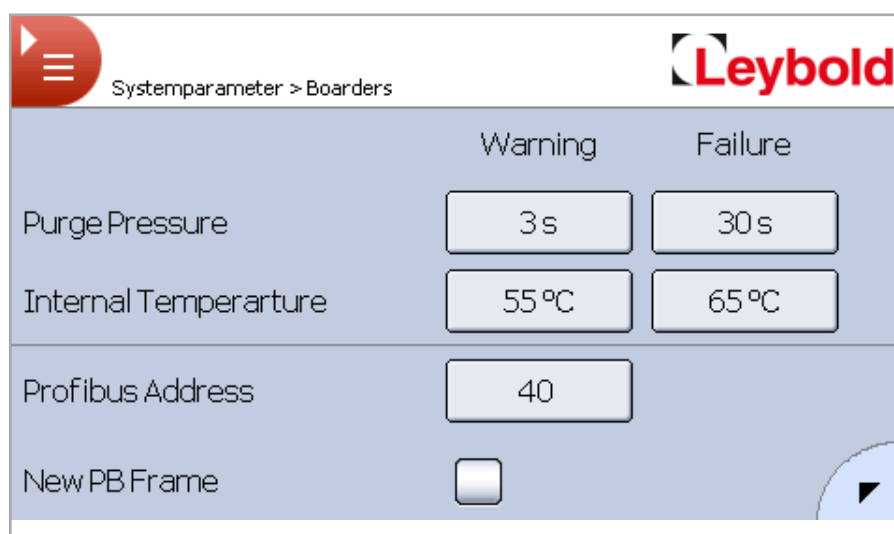

Fig. 4.21 System parameters limits

Pressing on the arrow at the bottom on the right-hand side and then on Behaviour opens a setup menu for the system behaviour. Here

- error handling can be changed.
- the point of time at which the Roots pump starts can be changed (at n % of the nominal speed; default is 90%).
- the piping volume can be set up. Depending on this value the purge valves are opened for some time when switching off the DRYVAC so as to fill the piping with nitrogen. When setting this value to 0, the purge valves remain closed.
- the status of the control location can be determined through LOCAL or the hardware inputs and outputs (HWIOs) or the Profibus (PB).
- the control rights can be assigned to the touch screen by pressing of LOCAL.

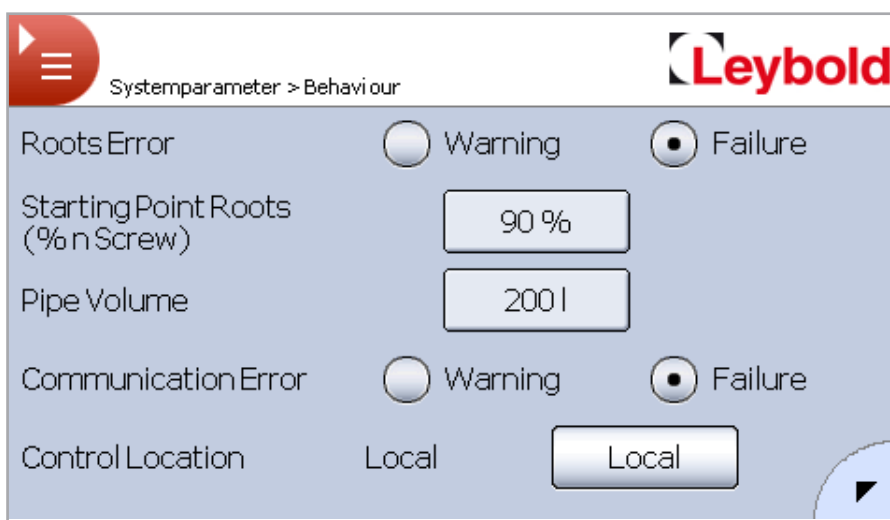

Fig. 4.22 Behaviour

4.4.4 Warning and Shut-off Thresholds

	Designation	Warning threshold	Warning display	Shut-off threshold	Fault display
Exhaust pressure (Pressure difference to ambient pressure)	PSH 200	–		250 +/- 50 mbar	
Purge gas supply pressure (optional)	PSL 220	–		2.4 bar(g)*	
Pump housing internal temperature	TSH 284	50 °C		–	

* selectable at the display if evaluated as warning or as fault

No	Time & Date		Device
1	13:43:01 15.06.11	✓◀✖	Screw
2	13:43:01 15.06.11	✓◀✖	Roots
3	13:42:59 15.06.11	▶✓✖	Screw
4	13:42:59 15.06.11	▶✓✖	Roots
5	13:42:45 15.06.11	▶✖	Screw

Control buttons: [Home] [Left] [-] [+] [Right] [Acknowledge] [Reset]

Fig. 4.23 Failure list

4.4.5 Failure list

In the submenu item LISTS > “Alarm/warning” warnings or alarms are displayed. Here the icons indicate the following:

- ▶ Message “is coming”.
- ◀ Message “is going” but has not yet been acknowledged.
- ▶ ✓ Message “is coming” and has been acknowledged.
- ◀ ✓ Message “is going” and has been acknowledged.
- ✓ ▶ Message has been acknowledged and will “go” only thereafter.

The five messages are displayed in combination with the status icon given below:



The Acknowledge button is only for documentation “I have seen the error/the warning”. It will not reset the error.

The error reset is initiated separately through the Reset button.

Depicted in the figure above is an example of an error message:

Line 5: the error message is coming in.

Line 3: the Acknowledge button has been operated, but the error is still pending.

Line 1: the Reset button has been operated, the error has been cancelled and was already acknowledged before.

Through the buttons - and + move to the in each case next five error messages.

Further to the right in the list, a description of the errors can be found.

For a list of error messages please refer to Section 6.

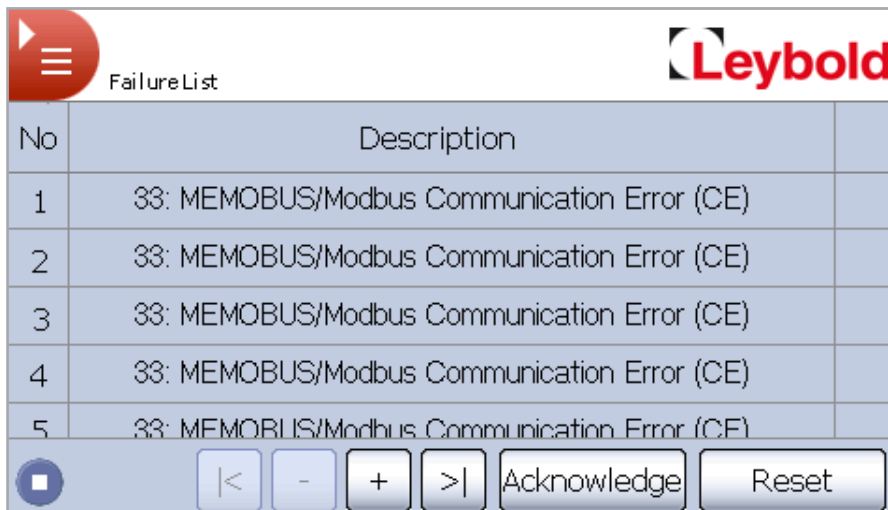

The screenshot shows a software interface titled "FailureList" with the Leybold logo in the top right corner. It features a table with two columns: "No" and "Description". The table contains five rows, all with the same description: "33: MEMOBUS/Modbus Communication Error (CE)". Below the table is a control bar with a play button, navigation arrows (left and right), minus and plus signs, and "Acknowledge" and "Reset" buttons.

No	Description
1	33: MEMOBUS/Modbus Communication Error (CE)
2	33: MEMOBUS/Modbus Communication Error (CE)
3	33: MEMOBUS/Modbus Communication Error (CE)
4	33: MEMOBUS/Modbus Communication Error (CE)
5	33: MEMOBUS/Modbus Communication Error (CE)

Fig. 4.24 Failure list: Description

Operation

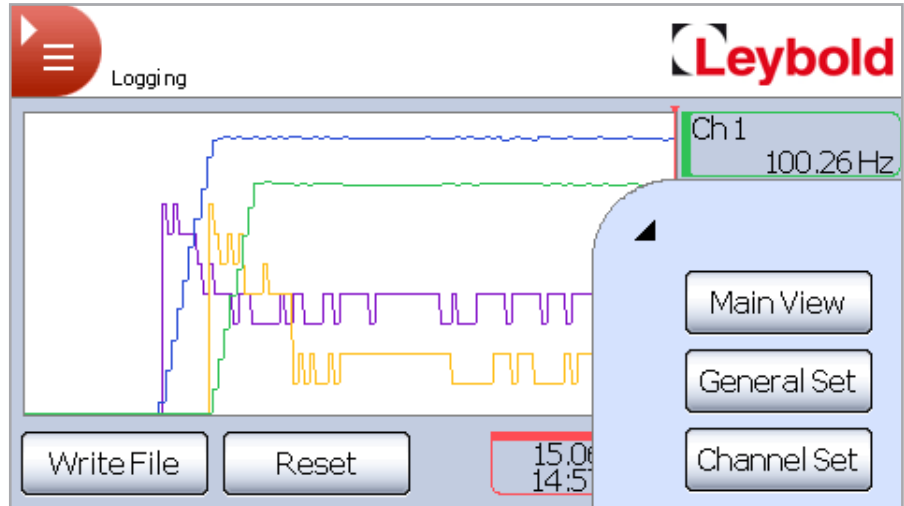

Fig. 4.25 Logging main screen

4.4.6 Logging

In the submenu Logging, up to 4 pre-set measured values can be recorded along a time axis. Instead of Ch1 to Ch4 names can be assigned to the values. "Write file" transfers the recorded data to a storage medium connected to the USB interface. "Reset" deletes the recorded data and permits a new recording. Internally, the data logger is always active.

The internal data memory is capable of storing only the amount of one graphic display. It has been designed by way of a ring memory, i.e. data which is newly measured will overwrite old no longer displayed values.

Operating the small triangle on the right at the bottom invokes the logging settings.

The red cursor line can be moved in the graphic display to the left and to the right and will then indicate the values measured at the selected point of time.

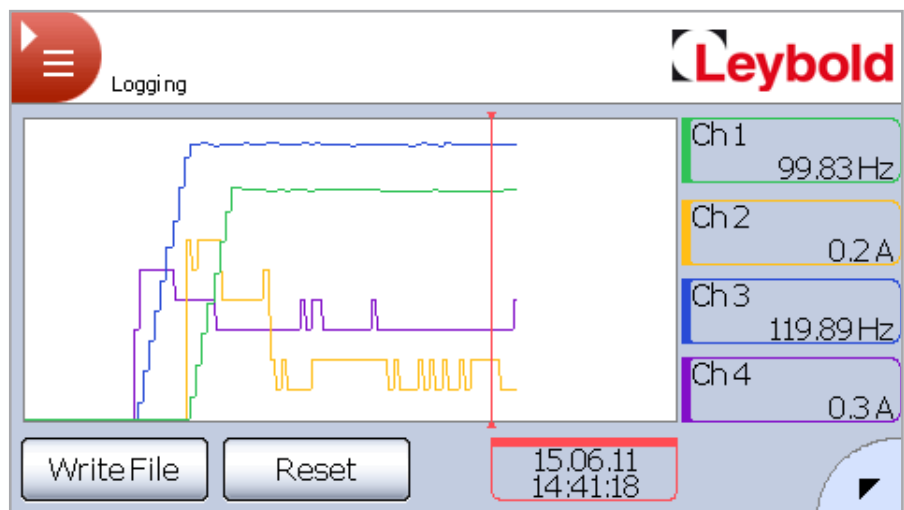

Fig. 4.26 Logging

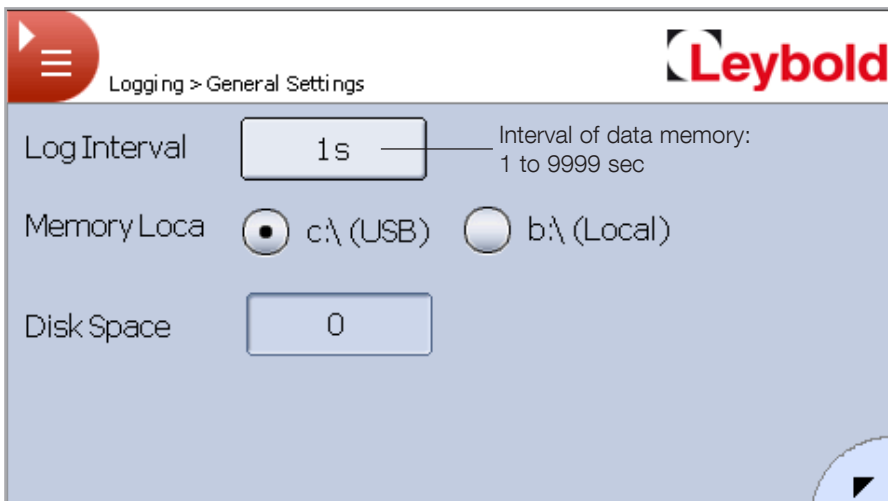

Fig. 4.27 Logging: general settings

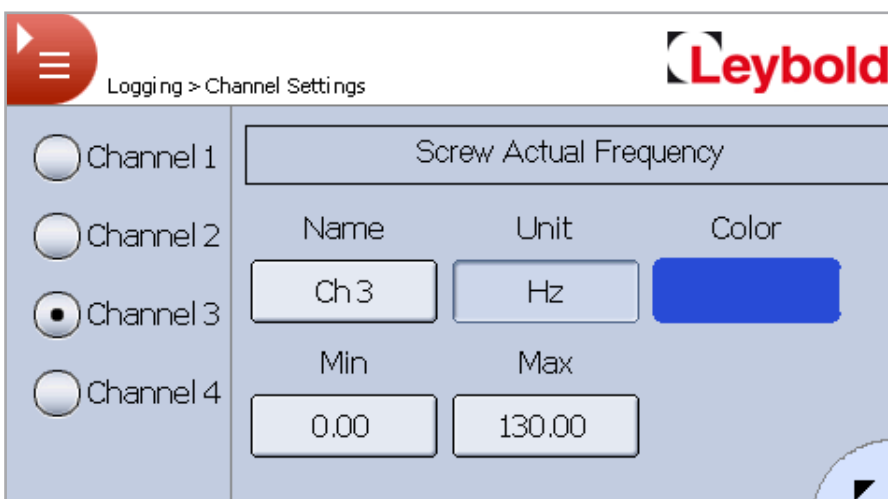

Fig. 4.28 Logging: channel settings

The 4 measurement channels can be renamed and the colour assignment can be changed. Moreover, the graphic display can be scaled. Changes in this menu will not affect the recorded measured values.

4.4.7 Settings

Time & Date



Fig. 4.29 SETTINGS > Time & Date

Network

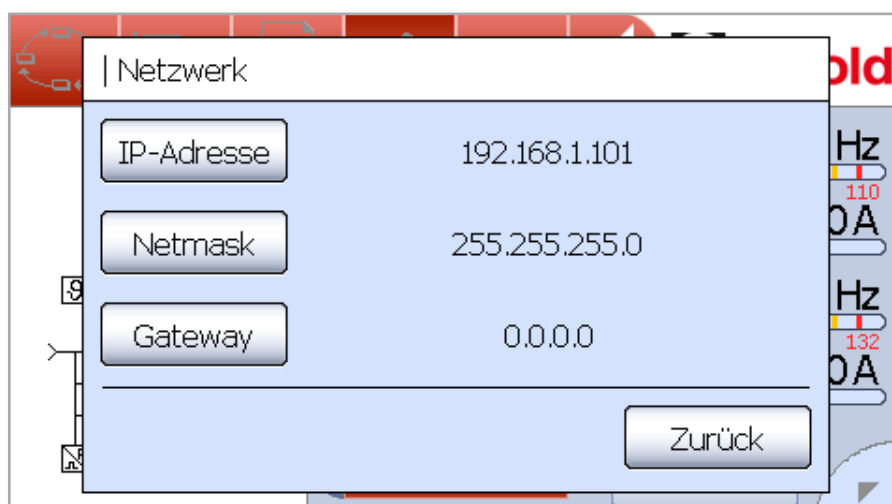

Fig. 4.30 SETTINGS > Network

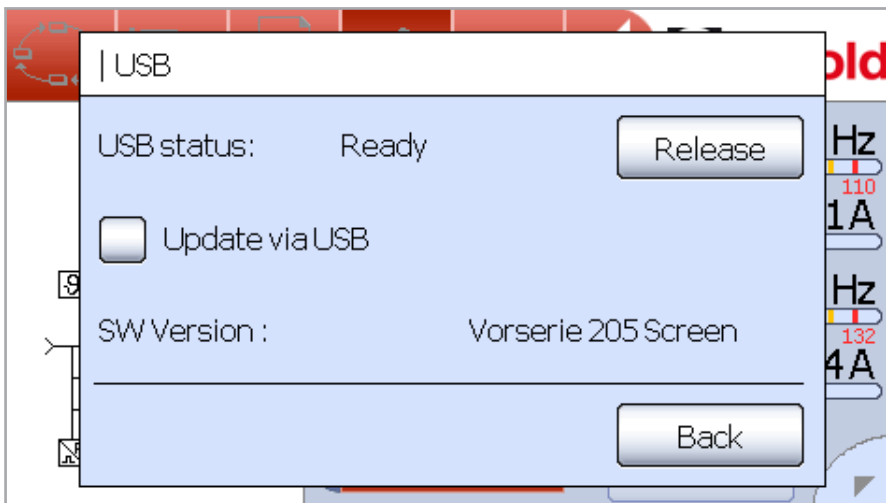

Fig. 4.31 SETTINGS > USB

USB – Software Update

Through the submenu item SETTINGS > USB it is possible to run software updates.

The USB interface is a master interface to which only memory media but no PC can be connected.

In order to access the USB interface, remove the front panel. The USB interface is provided on a short extension cable.

Insert the memory stick (with all update files) into the front USB interface connector.

Wait for “USB Status:” to switch from “Remove” to “Ready”.

Check the checkbox “Update via USB”.

Should the display not change within approximately 1 minute to “Ready”, then please first start the file “USB Format” and follow the instructions. This program will then format of the USB memory stick so that it will be compatible to the DRYVAC.

After approximately 10 to 20 seconds a white boot window will be displayed.

When the white boot window has started, never switch off the power supply at the touch panel or at the pump.

After having successfully loaded the files, the bottommost line will display the text: “RESTART MACHINE” and the green system LED on the front panel will flash.

Now switch the mains power off, remove the memory stick and switch on again. Thereafter this system should boot up again.

NOTICE



NOTICE



Operation

Should starting of the system end with the error message “Error with update, can’t open boot block” then you will have to repeat the process once more!

Fit the front panel again.

The Ethernet interface is provided for future applications.

Screensavers

Through the submenu item SETTINGS > Screensaver one of two screensavers is enabled:

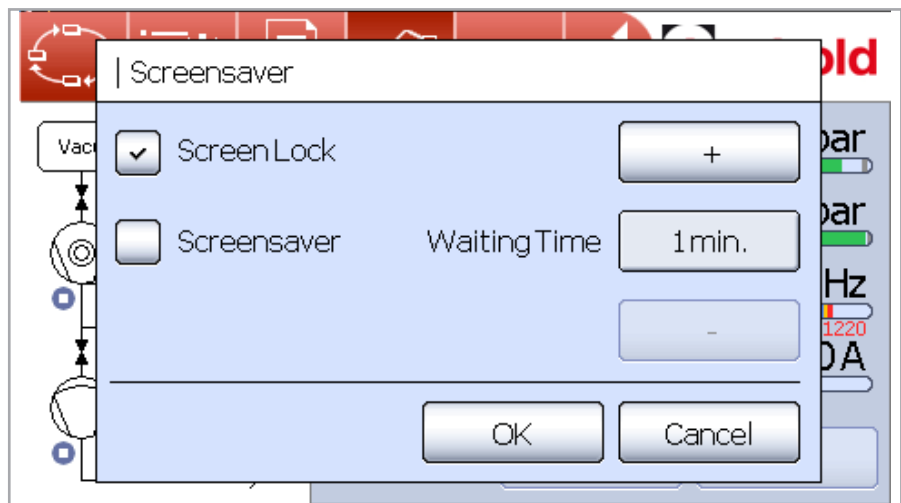

Fig. 4.32 SETTINGS > Screensaver

- “Screen lock“: for protection against invoking touch panel functions inadvertently. Checking the checkbox “Screen lock” will - after the pre-set time has elapsed - lock the menu and switching functions. Entries can only be made once more after unlocking the display through pressing the buttons “1” to “4” in the correct sequence.

The displayed measured values are updated when “Screen lock“ is running.



Fig. 4.33 Unlock screensaver

- “Screensaver“: this extends the service life of the display.
Checking the checkbox “Screensaver“ switches the display off after a pre-set time span has elapsed. The yellow LED on the front panel indicates that the DRYVAC is running.
The display is re-enabled by operating the buttons “1” to “4” in the correct-sequence.
In case of an error, the screensaver function is automatically disabled.

Language

see Section 4.3.

Info

The submenu item SETTINGS > Info will indicate the loaded software version and the current number of operating hours of the DRYVAC.

4.5 Shut-off and Venting

When operation is finished switch the pump off. Proceed as follows

- Isolate the pump from the chamber but keep it running.
- When pumping **condensable media** (water, for example) continue to operate the pump at a gas throughput, which is as high as possible for at least 30 minutes to dry it.
- Run the pump for at least 15 minutes with purge gas to ensure that it is free of process gases and dry.
- Switch off the pump.

Low purge gas flow during shut-off may damage the pump.

The pump must only be vented such that **atmospheric pressure is never exceeded.**

If the pump has previously pumped hazardous gases observe Safety Information in Section 0.4 and those in the Safety Booklet.

Open the pump only in the completely vented state and only as short as possible. Otherwise humidity will collect on the inner surfaces. This will then, during subsequent evacuation, result in significantly longer pumpdown times until attaining the desired ultimate pressure.

If during longer downtimes the system shall remain conditioned for a rapid pumpdown, we recommend to vent in the system with dry nitrogen to atmospheric pressure and maintain it in this condition without opening it.

DANGER



Operation

Process pump recovery after pump failure

In the event of a process pump stopping during a process step there is risk that the pump could contain hazardous materials, the following procedure should be followed in order to minimise the risk to people and property.



If the pump has previously pumped hazardous gases observe Safety Information in Section 0.4.

- Interlock the process valve to close when the process pump stops.
- Vent the system with the relevant purge gas to atmospheric pressure.
- Purge the system for at least 15 minutes by opening all installed purge gas valves. With no purge gas connected to the pump, use a gas flow from the process side or a separate gas cylinder to purge the pump for at least 15 minutes.
- In no event, drain the lubricant.
- Shut off the purge.
- Disconnect the pump exhaust and inlet and fit a metal ISO / NW blanking plate.
- Disconnect the purge gas supply and seal.
- The pump can now be removed to a workshop for decontamination and repair, see Section 5.1.

4.6 Removing from Service

Shut off and vent the pump system as described above.

Clean the pump system of any substances which may lead to corrosion. (e.g. by extended purge).

Flood it with nitrogen or dry purge gas, add desiccant and seal it.

Drain cooling water

Remove the cooling water from the pump system.

Remove the cooling water hoses and quick couplings from the pump and drain the cooling water. Blow out the cooling water coils with compressed air or Nitrogen (**max. 4 bar**). Blow into the cooling water inlet port only.

Also when storing the pump for longer periods of time the lubricant remains in the pump.

5 Maintenance

5.1 Leybold Service

Whenever you send us in equipment, indicate whether the equipment is contaminated or is free of substances which could pose a health hazard. If it is contaminated, specify exactly which substances are involved. You must use the form we have prepared for this purpose.

A copy of the form has been reproduced at the end of these Operating Instructions: "Declaration of Contamination for Compressors, Vacuum Pumps and Components". Another suitable form is available from www.leybold.com/ -> Documents -> Download Documents.

Attach the form to each pump.

This statement detailing the type of contamination is required to satisfy legal requirements and for the protection of our employees.

We must return to the sender any equipment which is not accompanied by a contamination statement.

Contamination

Form

5.2 Maintenance Intervals

See the table for the recommended maintenance intervals for the pumps. We recommend a service contract with Leybold.

We recommend to inspect the pump system and all components after approximately 6 months under the process conditions. The inspection of the components shall let corrosion attacks become apparent at an early stage and indicate possible deposits of process dust. Depending on the findings, changed maintenance and replacement intervals can become necessary for specific components.

Service work	Interval
Check the oil level	1 year
Oil change for synthetic oil	1 year
Oil change for PFPE	not required
Replace the filter cartridge in the pressure reducer	1 year
Check the water hoses	1 year
Check the purge gas hoses	1 year
Complete overhaul in the service centre	depending on the specific operating conditions
Leak search on the entire pump system	after all maintenance and assembly work and upon request

CAUTION



5.3 Exchanging the Lubricant

Notice safety information 0.3 to 0.5.

The oil-fill port must be sealed air-tight. In the presence of a vacuum, the entry of air may cause oil-containing gas to enter the pumping chamber via the impeller seals.

When using PFPE as intended, PFPE is not subject to ageing. For this reason, it will not have to be exchanged. For safety reasons we recommend not to change the PFPE, since in the event of damage like mechanical failures, for example, hazardous decomposition products may form. Only topping up PFPE will make sense and is possible should the lubricant level be too low after improper transportation, for example.

Change the synthetic oil more frequently when pumping corrosive vapours or large amounts of dust.

WARNING



Before removing the oil-drain or oil-fill plug always **switch off the pump first** and vent to atmospheric pressure.

When the pump has become warm during operation the casing and the oil temperature may exceed 80 °C.

Leave the pump to cool down. Always wear protective gloves also to protect yourself against aggressive residues in the oil.

Remove the top and lateral covers. Note the ground wire. Unscrew the oil-drain plugs and the oil-fill plugs and drain the oil.

Clean the sealing surface and firmly reinstall the oil-drain plugs using a gasket which is in perfect condition. Wipe off any oil residues from the casing.

Fill in new oil at a pump temperature of 15 °C to 25 °C. For this use a clean funnel.

Make sure to use the right kind of oil. Only use Leybold oil.

Please consult us if you intend to run the pump with other oils or special lubricants.

Observe the correct oil fill levels for the shutdown (standing still) pump.

NOTICE



If the oil level is too low, the bearings and gearwheels are not lubricated adequately; if it is too high, oil may enter the pumping chamber.

Clean the oil-fill port and reinstall the plug using a gasket which is in perfect condition. Wipe off any oil residues from the casing.

Manually tighten the oil-fill plugs (tightening torque of approximately 10 – 15 Nm). Mount all covers before starting operations again.

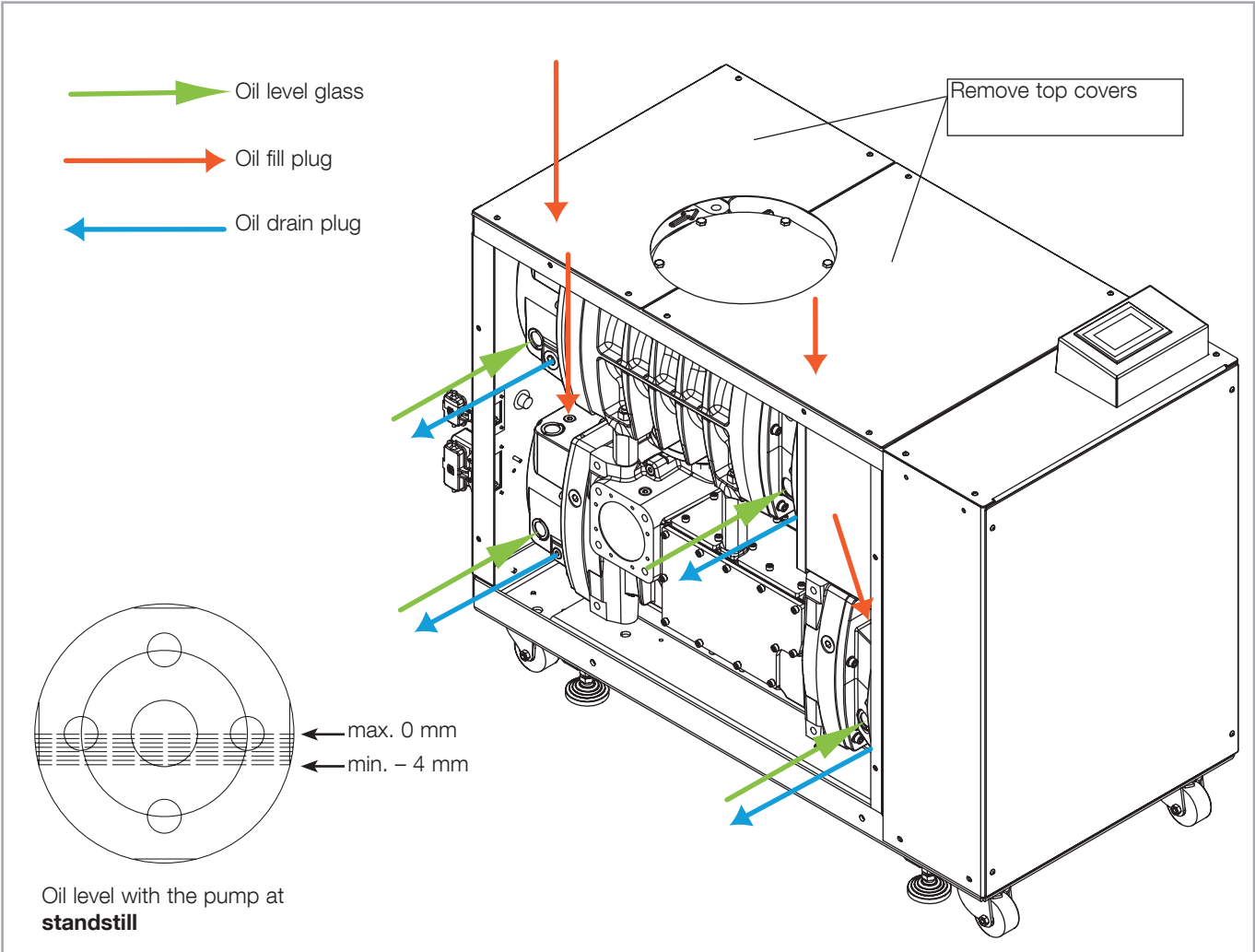

Fig. 5.1 Oil change DRYVAC DV 5000-i

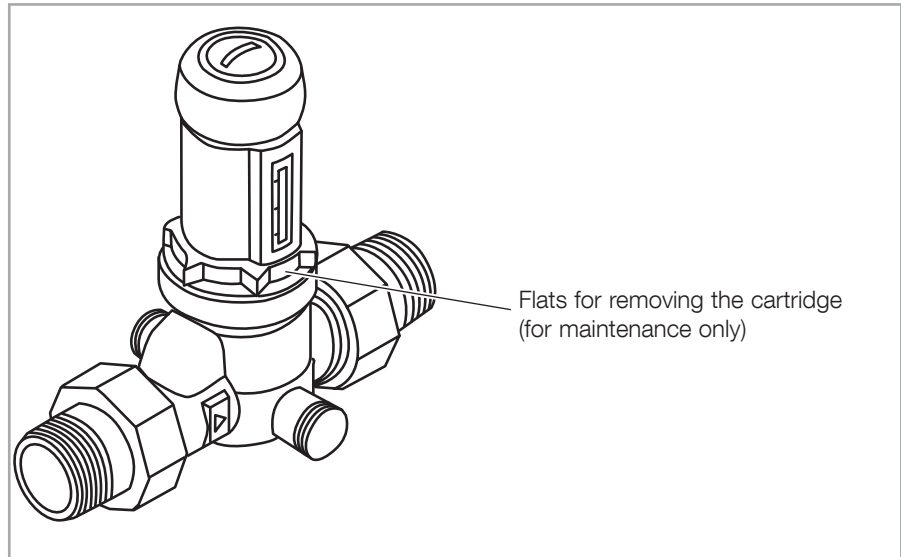

Fig. 5.2 Water pressure reducer (schematic drawing, different types are used in the DRYVAC)

5.4 Cleaning the Filter Insert in the Cooling Water Pressure Reducer

Shut off the cooling water supply and discharge.

Unscrew the cartridge.

For this, a 27 mm hexagon pipe wrench is required. The adjustment knob can be pulled off should the inside of the wrench be too narrow.

Clean the filter insert with plain cold water.

Screw the cartridge (thread: 39x1.5) back in, tightening torque 20 Nm.

Open the water supply and discharge again, check leak tightness and pressure setting.

5.5 Replacing the Filter Cartridge in the Purge Gas Pressure Reducer

Notice safety information in Section 0.

CAUTION



The filter cartridge in the purge gas module pressure reducer must be replaced annually.

See Fig. 3.5.

For replacing, unscrew the metal protection basket with cup from the pressure reducer. Unscrew the mounting component and detach the used filter cartridge. Fit the parts using a new filter cartridge again.

Maintenance

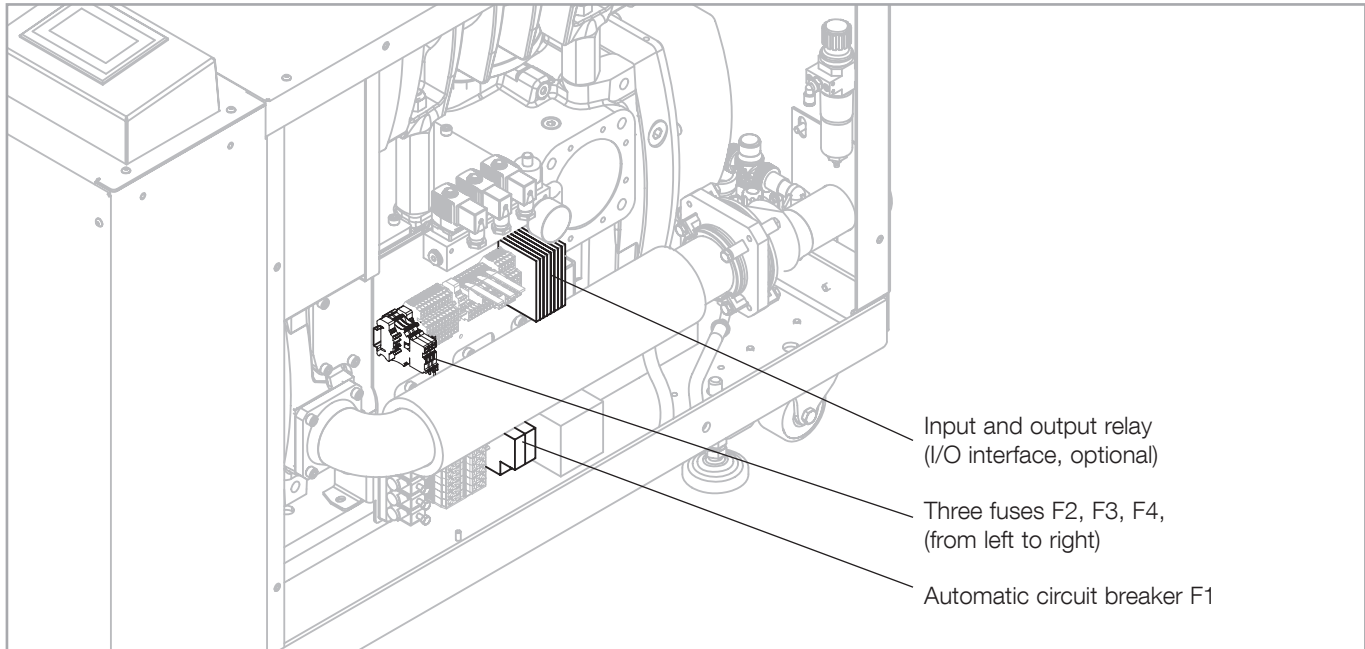

Fig. 5.3 DRYVAC DVR 5000: fuses

5.6 Fuse Replacement

The DRYVAC is equipped with three replaceable fuses as well as an automatic circuit breaker F1.

Fuse	for
F2 2 AT	Valves SV 40-42, pressure switch PSL
F3 0.5 AT	Display, Profibus
F4 0.5 AT	I/O Interface

The holders for the three fuses are equipped with LEDs which light up in the case of a blown fuse.

CAUTION



Note the safety information provided in Section 0.

Deviating with respect to the safety information provided in Section 0 it is recommended to power up to test the fuses. Since then voltage carrying parts become accessible, such work must only be done by a trained electrician in accordance with VDE 0105 (DIN EN 50110-1). Please also take note of the national regulations which apply in the country where the equipment is being installed. Moreover, also make sure that the pump cannot start up once the side panel cover is open.

6 Troubleshooting

All Alarm and fault messages for the DRYVAC DVR 5000 start with “Screw” or “Booster”, so that they can be assigned to the correct pump. The information in brackets, e.g. “Uv1” corresponds to the display of the integrated frequency converter.

6.1 Fault Messages of a Pump Stage

When an fault occurs the pump will be switched off.

No.	Display	Possible cause	Corrective Action
2	Undervoltage (Uv1)	Input power phase loss. The main circuit pump input power is wired incorrectly. There is a problem with the voltage from the drive input power The power has been interrupted. The input power transformer is not large enough and voltage drops after switching on power. Internal circuitry has become worn.	Correct the wiring. Check the mains voltage. Check the mains voltage. Correct the voltage to within range listed in this manual. Correct the mains supply voltage. Check the capacity of the input power transformer. Leybold Service
3	Control Power Supply Under-voltage (Uv2)	The wiring for the control power supply is damaged.	Check control wiring. Leybold Service if fault reoccurs.
4	Soft Charge Circuit Fault (Uv3)	Internal fault	Leybold Service
6	Ground Fault (GF)	Motor insulation is damaged. A damaged motor cable is creating a short circuit. Internal FC fault	Check the insulation resistance of the motor. Check the motor cable. Leybold Service
7	Overcurrent (oC)	The acceleration or deceleration times are too short. Motor insulation is damaged. A damaged motor cable is creating a short circuit. Internal FC fault	Leybold Service Check the insulation resistance of the motor. Check the motor cable. Leybold Service
8	Overvoltage (ov)	Deceleration time is too short. Surge voltage entering from the mains supply voltage. Mains supply voltage is too high.	Leybold Service Check the mains supply voltage.
9	Heatsink Overheat (oH)	Cooling water temperature is too high. Internal cooling fan is stopped.	Check the cooling water condition Leybold Service

Troubleshooting

Fault Messages of a Pump Stage (Continued)

No.	Display	Possible cause	Corrective Action
10	Heatsink Overheat (oH1)	Cooling water temperature is too high. Internal cooling fan is stopped. The internal cooling fan has reached its performance life or has malfunctioned.	Check the cooling water condition Leybold Service Leybold Service
11	Motor Overload (oL1)	Pump load too high	Reduce load of the pump.
12	Drive Overload (oL2)	Pump load too high Cycle times are too short during acceleration and deceleration.	Reduce load of the pump.
13	Overtorque Detection 1 (oL3)	Pump load too high Parameter settings are not appropriate for the type of load.	Reduce load of the pump Leybold Service
14	Overtorque Detection 2 (oL4)	Parameter settings are not appropriate for the type of load.	Leybold Service
15	Dynamic Braking Transistor (rr)	The braking transistor or the control circuit is damaged.	Leybold Service
16	Braking Resistor Overheat (rH)	Deceleration time is too short.	
17/ 18/ 19/ 20	External Fault at Input Terminal S3 (EF3)/ S4 (EF4)/ S5 (EF5)/ S6 (EF6)		Check wiring.
25	Input Phase Loss (PF)	There is phase loss in the pump mains power. There is excessive fluctuation in the mains voltage. There is poor balance between voltage phases. The main circuit capacitors are worn.	Check for wiring errors in the mains circuit. Correct the wiring. Stabilize drive input power. Leybold Service
26	Output Phase Loss (LF)	Frequency converter fault	Leybold Service
27	Motor Overheat (PTC input) (oH3)	Too few cooling water Pump load too high	Ensure sufficient cooling water supply. Reduce load of the pump

Fault Messages of a Pump Stage (Continued)

No.	Display	Possible cause	Corrective Action
28	Digital Operator Connection (oPr)	Internal fault	Leybold Service
29	EEPROM Write Error (Err)	Internal fault	Leybold Service
30	Motor Overheat (PTC input) (oH4)	Too few or too warm cooling water Pump load too high	Ensure sufficient cooling water supply. Reduce load of the pump.
33	MEMOBUS/Modbus Communication Error (CE)	A data error occurred due to noise.	Reduce noise to standard industrial values
34	Option Communication Error (bUS)	Communication error with optional board, e.g. relay board.	Check optional board.
37	Control fault (CF)	Internal fault	Leybold Service
39	PROFIBUS-DP Option External Fault (EF0)	Communication error with optional Profibus board	Check optional board.
40	PID Feedback Loss (FbL)		Leybold Service
41	Undertorque Detection 1 (UL3)	Motor turns, no load: Fault in drive chain.	Leybold Service
42	Undertorque Detection 2 (UL4)	Motor turns, no load: Fault in drive chain.	Leybold Service
43	High Slip Braking Overload (oL7)		Leybold Service
48	Hardware Fault (including oFx)	Internal fault	Leybold Service
54	Output Current Imbalance (LF2)		Leybold Service
55	Pullout Detection (Sto)		Check wiring. If no error is detected contact Leybold Service.
56	PG Disconnected (PGo)		Check wiring. If no error is detected contact Leybold Service.

Troubleshooting

Fault Messages of a Pump Stage (Continued)

No.	Display	Possible cause	Corrective Action
59	Too Many Speed Search Restarts (SEr)		Leybold Service
60	Low Speed Detected		Set higher speed.
61	Wrong Terminal Board		Check wiring. If no error is detected contact Leybold Service.
62	PT1000 Open	Open circuit is detected. Note "Wait" alarm.	Check Pt 1000 and connection cable, replace if required.
63	PT1000 Short Circuit	Short circuit is detected.	Check Pt 1000 and connection cable, replace if required
64	PT1000 Fault	Temperature measured with the Pt 1000 is too high. Note "Wait" alarm.	Check and improve cooling
65	PID Feedback Loss (FbH)	Frequency converter defective	Leybold Service
67	External Fault 2, Input Terminal S2 (EF2)	Exhaust pressure too high. Exhaust pressure switch defective. Wiring fault	Open all shutoff devices in the exhaust, clean exhaust, install exhaust line with sufficient diameter. Check exhaust pressure switch, replace if required. Check wiring.
68 to 105	div.	Internal faults.	Switch DRYVAC off and on again. If the fault is still displayed contact Leybold Service and state the fault number and displayed text.
113 to 117	div. acc. to options	Internal faults.	Switch DRYVAC off, check installed options and switch DRYVAC on again. If the fault is still displayed contact Leybold Service and state the fault number and displayed text.

6.2 Alarm Messages of a Pump Stage

The pump continues running when an alarm (warning) occurs.

No.	Display	Possible cause	Corrective Action
129	Undervoltage (Uv)	There is a problem with the voltage from the drive input power The input power transformer is not large enough and voltage drops after switching on power. Internal circuitry has become worn.	Check the mains voltage. Correct the voltage to within range listed in this manual. Correct the mains supply voltage. Check the capacity of the input power transformer. Leybold Service
130	Overvoltage (ov)	Deceleration time is too short. Surge voltage entering from the mains supply voltage. Mains supply voltage is too high.	Leybold Service Check the mains supply voltage.
131	Heatsink Overheat (oH)	Cooling water temperature is too high. Internal cooling fan is stopped.	Check the cooling water condition Leybold Service
132	Drive Overheat (oH2)	Cooling water temperature is too high. Pump load too high Cycle times are too short during acceleration and deceleration.	Check the cooling water condition Reduce load of the pump.
133	Overtorque 1 (oL3)	Pump load too high Parameter settings are not appropriate for the type of load.	Reduce load of the pump Leybold Service
134	Overtorque 2 (oL4)	Parameter settings are not appropriate for the type of load.	Leybold Service
135	Run Commands Input Error (EF)		Input new run command.
136	Drive Baseblock (bb)	The software base block function is assigned to one of the digital inputs and the input is off. The frequency converter does not accept Run commands.	Check the digital inputs function selection. Check link between SC and S6.
137 to 140	External Fault, Input Terminal S3 (EF3)/ S4 (EF4)/ S5 (EF5)/ S6 (EF6)		Check wiring.

Troubleshooting

Alarm Messages of a Pump Stage (Continued)

No.	Display	Possible cause	Corrective Action
143	Cooling Fan Error (FAN)		Check fuse F1.
144	Overspeed (oS)		Leybold Service
145	Excessive Speed Deviation (dEv)		Leybold Service
146	PG Disconnected (PGo)		Check wiring. If no error is detected contact Leybold Service.
147	Digital Operator Connection Fault (oPr)	Internal fault	Check wiring. If no error is detected contact Leybold Service.
148	MEMOBUS/Modbus Communication Error (CE)	A data error occurred due to noise.	Reduce noise to standard industrial values
149	Option Communication Error (bUS)	Communication error with optional board, e.g. relay board.	Check optional board.
150	Serial Communication Transmission Error (CALL)	A data error occurred due to noise.	Reduce noise to standard industrial values. Check wiring. If no error is detected contact Leybold Service.
151	Motor Overload (oL1)	Pump load too high	Reduce load of the pump.
152	Motor Overload (oL1)	Pump load too high Cycle times are too short during acceleration and deceleration.	Reduce load of the pump Leybold Service
154	Option Card External Fault (EF0)	Communication error with optional board, e.g. relay board.	Check optional board.
155	Motor Switch Command Input During Run (rUn)	When the pump is running the control does not accept a motor reverse command.	
157	Serial Communication Transmission Error (CALL)		Check wiring. If no error is detected contact Leybold Service.

Alarm Messages of a Pump Stage (Continued)

No.	Display	Possible cause	Corrective Action
158	Undertorque Detection 1 (UL3)	Motor turns, no load: Fault in drive chain	Leybold Service
159	Undertorque Detection 2 (UL4)	Motor turns, no load: Fault in drive chain.	Leybold Service
160	MEMOBUS/ Modbus Test Mode Fault (SE)	A data error occurred due to noise.	Reduce noise to standard industrial values.
162	Motor Overheat (oH3)	Too few or too warm cooling water Pump load too high	Ensure sufficient cooling water supply. Reduce load of the pump.
167	PID Feedback Loss (FbL)	Frequency converter defective	Leybold Service
168	PID Feedback Loss (FbH)	Frequency converter defective	Leybold Service
170	Drive Disabled (dnE)		Leybold Service
171	PG Disconnected (PGo)		Check wiring. If no error is detected contact Leybold Service.
172	SFS Stop		Leybold Service
173 to 176	PT1000 Alarm1 PTC and PT1000-Alarm1 PT1000 Alarm2 PTC and PT1000-Alarm2	Occurs when Pt 1000 temperature is too high. Cooling water supply is not sufficient. Cooling water lines are clogged. Ambient temperature is too high or cooling air flow is obstructed. Pump is operating in the wrong pressure range. Gas temperature is too high. Clearance between housing and rotors are too small due to - contamination - distortion of the pump Friction resistance is too high due to contaminated bearings and/or contaminated lubricant. Lubricant level is too high. Lubricant level is too low. Wrong lubricant filled in. Bearing is defective.	Check and improve cooling. Ensure sufficient cooling water supply. Decalcify cooling water lines. Install the pump at a suitable place or ensure a sufficient flow of cooling air. Check the pressure levels within the system. Check system. Clean pumping chamber. Affix and connect the pump free of tension. Drain lubricant down to the correct level. Top up lubricant to the correct level. Leybold service Leybold Service.

Troubleshooting

Alarm Messages of a Pump Stage (Continued)

No.	Display	Possible cause	Corrective Action
180	High Current Alarm (HCA)		Check operating conditions.
186	External Fault (Input Terminal S2) (EF2)	Exhaust pressure too high. Exhaust pressure switch defective. Wiring fault	Open all shutoff devices in the exhaust, clean exhaust, install exhaust line with sufficient diameter. Check exhaust pressure switch, replace if required. Check wiring.
187	External Fault Safe Disable Input (HbbF)	Wiring fault	Check if jumper H1-HC is plugged in.
193	Wait	Condition for Pt 1000 Fault is reached. If the "Pt 1000 Open" threshold is reached within 10 seconds, then "Wait" changes to "Pt 1000 open", else it changes to "Pt 1000 fault". The fault is different to standard faults. There is no error code available and also no entry in the fault history. This ensures that only the faults "Pt 1000 open" and "Pt 1000 fault" can be seen or traced. As soon "Wait" is occurring the frequency converter stops with RUN to coast.	
197	Pre CE Alarm	Alarm is active for the time P5-01 before H5-09 elapsed during Memobus Communication error.	
198	External Alarm during delay of MFDI set in S2	"Forerunner" for Alarm 186. Waiting time until alarm 186 is displayed.	
200	C-Lim Alarm	Drive was running at or above the Final Current Limit for a too long time.	Leybold Service

6.3 Alarm and Fault Messages DRYVAC

No.	Display	Possible cause	Corrective Action
	Alarm Purge pressure switch: Value too low	Purge pressure too low	Check purge gas source, seal leaks, open valves.
	Fault Purge pressure switch: Value too low	Purge pressure too low	Check purge gas source, seal leaks, open valves.
	Alarm Housing temperature: Value too high	Ambient temperature > 40°C Cooling water temperature too high Mains voltage too high	Check pump ambient temperature. Check cooling water temperature and flow. Check mains voltage.

Troubleshooting

6.4 Pump Malfunctions

Malfunction	Possible cause	Corrective Action
Pump does not start up. Fault 67 or a Pt 1000 fault is displayed.	Motor incorrectly connected.	Connect motor correctly.
	Overtemperature switch or motor stator defective.	Leybold Service.
	Pressure switch is defective.	Replace the pressure switch.
	Lubricant is too thick.	Exchange the lubricant or warm up lubricant and pump.
	Motor rotor defective.	Leybold Service.
	Pump has seized: defective impellers, bearings or toothed gears.	Leybold Service.
Pump is extremely loud.	Bearing damage.	Repair pump.
	Thick particle deposits.	Clean pump, respectively perform maintenance.
	Defective silencer.	Repair silencer.
	High gas throughput with the discharge line open, without silencer.	Install discharge line or silencer.
Power consumption of the motor is too high. Pump is too loud.	Like „Pump gets too hot“.	Like malfunction „Pump gets too hot“.
	Incorrect mains voltage for the motor.	Connect the motor to the correct mains voltage.
	Motor stator defective.	Leybold Service.
	Motor rotor defective.	Leybold Service.
	Distances between housing and rotors is too small due to - contamination - distortion of the pump	Clean pumping chamber. Affix and connect the pump free of tensions.
	Bearing or gear damage.	Leybold Service, shutdown pump immediately.
	Pistons make contact with the housing.	Leybold Service, shutdown pump immediately.
	Rotor is running untrue.	Leybold Service, shutdown pump immediately.
	Oil slinger disc makes contact with the gear housing or the oil pipe.	Leybold Service.
	Oil pump is blocked or defective.	Leybold Service, shutdown pump immediately.

Troubleshooting

Malfunction	Possible cause	Corrective Action
Pump is losing lubricant.	Lubricant leak is apparent: Oil drain plug is leaky. Oil level glasses leaky. Gear cover is leaky. Puddle under the motor, leak in the seal. No lubricant leak is apparent: See malfunction „Lubricant in the pump chamber“.	Drain lubricant, firmly screw in a new oil drain plug with the gasket, fill in correct lubricant quantity Leybold Service. Replace the O-ring of the gear cover. Leybold Service, shutdown pump immediately. See malfunction „Lubricant in the pump chamber“.
Oil gets too dark.	Oil has been used up. Pump gets too hot.	Exchange the oil. See malfunction „Pump gets too hot“; after remedy of the malfunction, exchange the oil.
Lubricant in the pump chamber.	Lubricant level is too high. Lubricant is ejected from the system. Pump is not standing horizontally. Pump has a gas leak towards the outside. Pump has an internal leak. Piston rings are defective.	Drain the lubricant down to the correct level. Check system. Place the pump correctly. Run a leak search and pinpoint leaks. If the leak is not at the oil-fill or oil-drain plugs, return the pump to the Leybold Service. Leybold Service. Leybold Service.
Pump does not attain its pumping speed.	Intake screen is clogged. Motor incorrectly connected. Motor stator defective. Motor rotor defective. Vacuum pump system has a gas leak. Impeller play is too great. Bearing defective.	Clean intake screen. Connect motor correctly. Leybold Service. Leybold Service. Detect leak and seal it. Leybold Service. Leybold Service.

Troubleshooting

Malfunction	Possible cause	Corrective Action
No display	Fuse F3 defective (LED lights). Circuit breaker F1 has tripped.	Replace fuse 0.5 A (slow blow). Leybold Service
Valves SV40-42 don't work.	Fuse F2 defective (LED lights). PLC defective.	Replace fuse 2 A (slow blow). Leybold Service
Pressure switch PSL doesn't work.	Fuse F2 defective (LED lights). PLC defective.	Replace fuse 2 A (slow blow). Leybold Service
Profibus doesn't work.	Fuse F3 defective (LED lights). Circuit breaker F1 has tripped.	Replace fuse 0.5 A (slow blow). Leybold Service
I/O Interface (option) doesn't work.	Fuse F4 defective (LED lights). Circuit breaker F1 has tripped.	Replace fuse 0.5 A (slow blow). Leybold Service
Fan doesn't work	Circuit breaker F1 has tripped. Fan defective	Leybold Service Leybold Service

Wearing Parts / Disposal

7 Wearing Parts

Plug screws M16x1.5 with gasket (6 pieces) ES110003750
(oil fill plugs)

Filter cartridge for purge gas pressure reducer E110000850

Pressure reducing cartridge, including filter, for cooling water unit E6519936

8 Waste Disposal

The equipment may have been contaminated by the process or by environmental influences. In this case the equipment must be decontaminated in accordance with the relevant regulations. We offer this service at fixed prices. Further details are available on request.

Contaminated parts can be detrimental to health and environment.

Before beginning with any work, first find out whether any parts are contaminated. Adhere to the relevant regulations and take the necessary precautions when handling contaminated parts.

Separate clean components according to their materials, and dispose of these accordingly. We offer this service. Further details are available on request.

When sending us any equipment, observe the regulations given in Section "5.1 Leybold Service".

Disposal of Waste Oil

Owners of waste oil are entirely self-responsible for proper disposal of this waste.

Waste oil from vacuum pumps must not be mixed with other substances or materials.

Waste oil from vacuum pumps (Leybold oils which are based on mineral oils) which are subject to normal wear and which are contaminated due to the influence of oxygen in the air, high temperatures or mechanical wear must be disposed of through the locally available waste oil disposal system.

Waste oil from vacuum pumps which is contaminated with other substances must be marked and stored in such a way that the type of contamination is apparent. This waste must be disposed of as special waste.

European, national and regional regulations concerning waste disposal need to be observed. Waste must only be transported and disposed of by an approved waste disposal vendor.

PFPE from vacuum pumps may be regenerated, if required, and provided the quantities are large enough. For this, please contact us for assistance.

Contamination

WARNING



EU Declaration of Conformity

(Translation of original Declaration of Conformity)

The manufacturer: Leybold GmbH
Bonner Strasse 498
D-50968 Köln
Germany

herewith declares that the products specified and listed below which we have placed on the market, comply with the applicable EU Directives. This declaration becomes invalid if modifications are made to the product without agreement of Leybold GmbH.

Product designation: Screw vacuum pump DRYVAC
Type designation: DV450, DV650, DVR5000, DV1200
Part numbers: 112045VXX-Z, 112065VXX-Z, 112500VXXX-Z, 112120VXX-Z
XXX=01-10; 15-999, Z=1-9

The products complies to the following Directives:

Machinery Directive (2006/42/EC)

The safety objectives of the Low Voltage Directive 2014/35/EU were complied with in accordance with Appendix 1 No. 1.5.1 of Machinery Directive 2006/42/EC.

Electromagnetic Compatibility (2014/30/EU)

The following harmonized standards have been applied:

EN 1012-2:1996+A1:2009	Compressors and vacuum pumps - Safety requirements Part 2: Vacuum pumps
EN 61010-1:2010	Safety requirements for electrical equipment for measurement, control, and laboratory use — Part 1: General requirements
EN 61326-1:2013	Electrical equipment for measurement, control and laboratory use — EMC requirements — Part 1: General requirements Emissions: Group 1, Class A Immunity: Industrial electromagnetic environment

Documentation officer: Herbert Etges
T: +49(0)221 347 0
F: +49(0)221 347 1250
documentation@leybold.com

Cologne, September 01, 2016

Cologne, September 01, 2016



ppa. Martin Tollner
VP / Head of Product Lines



ppa. Dr. Monika Mattern-Klosson
Head of Quality & Business Process Management

Document No.: 300320018-001-A6

All DRYVAC-i pumps have been certified by the TÜV Rheinland of North America according to the requirements of

- UL 61010-1: 2012
- CAN/CSA-C22.2 No.61010-1-12

The components are in compliance to the tested standards.

- TÜVus Certificate No. CU 72140399 01/02

The TÜV Rheinland of North America is a “Nationally Recognized Testing Laboratory” (**NRTL**) for the USA and Canada.

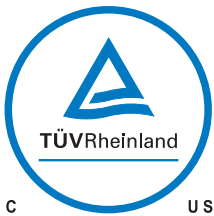

This product has been certified to the requirements of CAN/CSA-C22.2 No. 61010-1-12, or a later version of the same standard incorporating the same level of testing requirements.

Declaration of Contamination of Compressors, Vacuum Pumps and Components

The repair and / or servicing of compressors, vacuum pumps and components will be carried out only if a correctly completed declaration has been submitted. Non-completion will result in delay. The manufacturer can refuse to accept any equipment without a declaration.

A separate declaration has to be completed for each single component.

This declaration may be completed and signed only by authorized and qualified staff.

Customer/Dep./Institute : _____ Address : _____ _____ Person to contact: _____ Phone : _____ Fax: _____ End user: _____	Reason for return: <input checked="" type="checkbox"/> applicable please mark Repair: <input type="checkbox"/> chargeable <input type="checkbox"/> warranty Exchange: <input type="checkbox"/> chargeable <input type="checkbox"/> warranty <input type="checkbox"/> Exchange already arranged / received Return only: <input type="checkbox"/> rent <input type="checkbox"/> loan <input type="checkbox"/> for credit Calibration: <input type="checkbox"/> DKD <input type="checkbox"/> Factory-calibr. <input type="checkbox"/> Quality test certificate DIN 55350-18-4.2.1
--	--

A. Description of the Leybold product:

Material description : _____
 Catalog number: _____
 Serial number: _____
 Type of oil (ForeVacuum-Pumps) : _____

Failure description:

Additional parts: _____

Application-Tool: _____

Application- Process: _____

B. Condition of the equipment

	No ¹⁾	Yes	No
1. Has the equipment been used	<input type="checkbox"/>	<input type="checkbox"/>	<input type="checkbox"/>
2. Drained (Product/service fluid)	<input type="checkbox"/>	<input type="checkbox"/>	<input type="checkbox"/>
3. All openings sealed airtight	<input type="checkbox"/>	<input type="checkbox"/>	<input type="checkbox"/>
4. Purged	<input type="checkbox"/>	<input type="checkbox"/>	<input type="checkbox"/>

If yes, which cleaning agent _____
 and which method of cleaning _____

¹⁾ If answered with "No", go to D. ←

Contamination :

	No ¹⁾	Yes
toxic	<input type="checkbox"/>	<input type="checkbox"/>
corrosive	<input type="checkbox"/>	<input type="checkbox"/>
flammable	<input type="checkbox"/>	<input type="checkbox"/>
explosive ²⁾	<input type="checkbox"/>	<input type="checkbox"/>
radioactive ²⁾	<input type="checkbox"/>	<input type="checkbox"/>
microbiological ²⁾	<input type="checkbox"/>	<input type="checkbox"/>
other harmful substances	<input type="checkbox"/>	<input type="checkbox"/>

C. Description of processed substances (Please fill in absolutely)

1. What substances have come into contact with the equipment ?

Trade name and / or chemical term of service fluids and substances processed, properties of the substances
 According to safety data sheet (e.g. toxic, inflammable, corrosive, radioactive)

	Tradename:	Chemical name:
a)		
b)		
c)		
d)		

2. Are these substances harmful ? No Yes
3. Dangerous decomposition products when heated ? No Yes
- If yes, which ? _____

²⁾ Components contaminated by microbiological, explosive or radioactive products/substances will not be accepted without written evidence of decontamination.

D. Legally binding declaration

I / we hereby declare that the information supplied on this form is accurate and sufficient to judge any contamination level.

Name of authorized person (block letters) : _____

Date

signature of authorized person

firm stamp

24 V interface 42

A

Abatement 33

Atmospheric humidity 11

Atmospheric pressure 7, 23, 30, 37, 69, 70

B

Bellows 31-33

C

Check valve 16, 38, 39, 40

Circuit breaker 86

Compressed air 70

Condensate 7, 17, 33, 37

Contamination 22, 71, 87

Cooling water 8, 10, 11, 15, 17, 27, 34-36, 70-81, 83

Crane eyes 21, 25

D

Deposits 29, 33, 71, 84

Dimensional drawing 20

Discharge flange 23

Display 51, 55, 56, 74-83

E

Exhaust 17, 27, 31, 33, 39, 40, 61, 78, 82

Exhaust lines 33, 35, 51

Exhaust pressure 61, 78, 82

F

Fan 27, 80, 86

Feet 8, 14, 15, 16, 25, 26, 27

Fluorine 17, 23, 43, 87

Frequency converter 76, 78, 81

Fuse 74, 86

G

Gas ballast 11, 15, 19, 22

Gauge 38

Grounding 27, 41

GSD file 24, 43

H

Housing 41, 46, 47, 49, 83

Housing extraction 33

I

Intake flange 15, 17, 23

Intake line 14, 15, 32

Intake screen 14, 21, 85

L

Language selection 52

Leak search 11, 32, 71, 85

Liquid 14, 33

Logging 56, 64, 65

Lubricant 12, 21, 22, 81, 84, 85

Lubricant level 81, 85

M

Main switches 51

Media 43

N

Nitrogen 39, 40, 70

Noise 13, 22

Nozzle 23, 38

O

Oil 28, 39, 40, 71, 84, 85, 87

Oil level 28, 85

Operating mode 45, 46, 47, 50

P

Password 56-58

PFPE 12, 14, 16, 21, 22, 24-26, 28, 71, 87

PLC 16, 86

Potential equalisation 41

Pressure gauge 37

Pressure reducer 34, 35, 37, 71-73, 87

Pressure relief valve 17, 34

Pressure switch 37, 38, 74, 78, 82-84, 86

Profibus 16, 24, 42-45, 47, 48, 60, 61, 74, 77, 86

Pt 1000 39, 40, 78, 82, 84

Pumping speed curves 18, 19

purge gas 7, 11, 14, 16, 22, 23, 37, 38,

Purge gas 6, 7, 11, 14, 16, 17, 22, 23, 27, 37-40, 43, 51, 61, 69-71, 73, 83, 87

R

Rotor purge 23

S

Safety relief valve 39, 40

Screensaver 56, 68, 69

Shut-off Thresholds 61

Silencer 7, 13, 22, 24, 33, 84

T

Temperature Switch 39, 40

Touchscreen 16, 17, 51, 52, 58

U

USB interface 64, 67

V

Venting 69

Vibration 31, 32

Sales and Service

Germany

Leybold GmbH

Sales, Service, Support Center (3SC)
Bonner Strasse 498
D-50968 Cologne
T: +49-(0)221-347 1234
F: +49-(0)221-347 31234
sales@leybold.com
www.leybold.com

Leybold GmbH

Sales Area North

Branch Office Berlin
Industriestrasse 10b
D-12099 Berlin
T: +49-(0)30-435 609 0
F: +49-(0)30-435 609 10
sales.bn@leybold.com

Leybold GmbH

Sales Office South

Branch Office Munich
Karl-Hammerschmidt-Strasse 34
D-85609 Aschheim-Dornach
T: +49-(0)89-357 33 9-10
F: +49-(0)89-357 33 9-33
sales.mn@leybold.com
service.mn@leybold.com

Leybold Dresden GmbH

Service Competence Center

Zur Wetterwarte 50, Haus 304
D-01109 Dresden
Service:
T: +49-(0)351-88 55 00
F: +49-(0)351-88 55 041
info.dr@leybold.com

Europe

Belgium

Leybold Nederland B.V.

Belgisch bijkantoor

Leuvensesteenweg 542-9A
B-1930 Zaventem
Sales:
T: +32-2-711 00 83
F: +32-2-720 83 38
sales.zv@leybold.com
Service:
T: +32-2-711 00 82
F: +32-2-720 83 38
service.zv@leybold.com

France

Leybold France S.A.S.

Parc du Technopolis, Bâtiment Beta
3, Avenue du Canada
F-91940 Les Ulis cedex
Sales and Service:
T: +33-1-69 82 48 00
F: +33-1-69 07 57 38
info.ctb@leybold.com
sales.ctb@leybold.com

Leybold France S.A.S.

Valence Factory
640, Rue A. Bergès
B.P. 107
F-26501 Bourg-lès-Valence Cedex
T: +33-4-75 82 33 00
F: +33-4-75 82 92 69
marketing.vc@leybold.com

Great Britain

Leybold UK LTD.

Unit 9
Silverglade Business Park
Leatherhead Road
Chessington
Surrey (London)
KT9 2QL
Sales:
T: +44-13-7273 7300
F: +44-13-7273 7301
sales.in@leybold.com
Service:
T: +44-13-7273 7320
F: +44-13-7273 7303
service.in@leybold.com

Italy

Leybold Italia S.r.l.

Via Trasimeno 8
I-20128 Mailand
Sales:
T: +39-02-27 22 31
F: +39-02-27 20 96 41
sales.mi@leybold.com
Service:
T: +39-02-27 22 31
F: +39-02-27 22 32 17
service.mi@leybold.com

Netherlands

Leybold Nederland B.V.

Floridadreef 102
NL-3565 AM Utrecht
Sales and Service:
T: +31-(30) 242 63 30
F: +31-(30) 242 63 31
sales.ut@leybold.com
service.ut@leybold.com

Switzerland

Leybold Schweiz AG, Pfäffikon

Churerstrasse 120
CH-8808 Pfäffikon
Warehouse and shipping address:
Riedthofstrasse 214
CH-8105 Regensdorf
Sales:
T: +41-44-308 40 50
F: +41-44-302 43 73
sales.zh@leybold.com
Service:
T: +41-44-308 40 62
F: +41-44-308 40 60
service.zh@leybold.com

Spain

Leybold Spain, S.A.

C/. Huelva, 7
E-08940 Cornellà de Llobregat
(Barcelona)
Sales:
T: +34-93-666 43 11
F: +34-93-666 43 70
sales.ba@leybold.com
Service:
T: +34-93-666 46 11
F: +34-93-685 43 70
service.ba@leybold.com

Headquarter

Leybold GmbH

Bonner Strasse 498
D-50968 Cologne
T: +49-(0)221-347-0
F: +49-(0)221-347-1250
info@leybold.com

America

USA

Leybold USA Inc.

5700 Mellon Road
USA-Export, PA 15632
T: +1-724-327-5700
F: +1-724-325-3577
info.ex@leybold.com
Sales:
T: +1-724-327-5700
F: +1-724-333-1217
Service:
T: +1-724-327-5700
F: +1-724-325-3577

Brazil

Leybold do Brasil

Rod. Vice-Prefeito Hermenegildo Tonolli,
nº. 4413 - 6B
Distrito Industrial
Jundiá - SP
CEP 13.213-086
Sales and Service:
T: +55 11 3395 3180
F: +55 11 99467 5934
sales.ju@leybold.com
service.ju@leybold.com

Asia

P. R. China

Leybold (Tianjin)

International Trade Co. Ltd.
Beichen Economic
Development Area (BEDA),
No. 8 Western Shuangchen Road
Tianjin 300400
China
Sales and Service:
T: +86-22-2697 0808
F: +86-22-2697 4061
F: +86-22-2697 2017
sales.tj@leybold.com
service.tj@leybold.com

India

Leybold India Pvt Ltd.

No. 82(P), 4th Phase
K.I.A.D.B. Plot
Bommasandra Industrial Area
Bangalore - 560 099
Indien
Sales and Service:
T: +91-80-2783 9925
F: +91-80-2783 9926
sales.bg@leybold.com
service.bg@leybold.com

Japan

Leybold Japan Co., Ltd.

Headquarters
Shin-Yokohama A.K.Bldg., 4th floor
3-23-3, Shin-Yokohama
Kohoku-ku, Yokohama-shi
Kanawaga 222-0033
Japan
Sales:
T: +81-45-471-3330
F: +81-45-471-3323
sales.yh@leybold.com

Leybold Japan Co., Ltd.

Tsukuba Technical Service Center
1959, Kami-yokoba
Tsukuba-shi, Ibaraki-shi 305-0854
Japan
Service:
T: +81-29 839 5480
F: +81-29 839 5485
service.iik@leybold.com

Malaysia

Leybold Malaysia

Leybold Singapore Pte Ltd.

No. 1 Jalan Hi-Tech 2/6
Kulim Hi-Tech Park
Kulim, Kedah Darul
Aman 09000
Malaysia
Sales and Service:
T: +604 4020 222
F: +604 4020 221
sales.ku@leybold.com
service.ku@leybold.com

South Korea

Leybold Korea Ltd.

3F. Jellzone 2 Tower
Jeongja-dong 159-4
Bundang-gu Sungnam-si
Gyeonggi-do
Bundang 463-384, Korea
Sales:
T: +82-31 785 1367
F: +82-31 785 1359
sales.bd@leybold.com
Service:
623-7, Upsung-Dong
Cheonan-Si
Chungcheongnam-Do
Korea 330-290
T: +82-41 589 3035
F: +82-41 588 0166
service.cn@leybold.com

Singapore

Leybold Singapore Pte Ltd.

8 Commonwealth Lane #01-01
Singapore 149555
Singapore
Sales and Service:
T: +65-6303 7030
F: +65-6773 0039
sales.sg@leybold.com
service.sg@leybold.com

Taiwan

Leybold Taiwan Ltd.

No 416-1, Sec. 3
Chunghsin Rd., Chutung
Hsinchu County 310
Taiwan, R.O.C.
Sales and Service:
T: +886-3-500 1688
F: +886-3-583 3999
sales.hc@leybold.com
service.hc@leybold.com