

High Vacuum Pumps

TURBOVAC / TURBOVAC MAG

Turbomolecular Pumps

DIP / OB

Oil Diffusions Pumps

COOLVAC

Cryo Pumps

COOLPOWER

Cold Heads

COOLPAK

Compressor Units

240.00.02

Excerpt from the Leybold Full Line Catalog 2016

Catalog Part High Vacuum Pumps

Edition: Fall 2016

Contents

High Vacuum Pumps

Turbomolecular Pumps TURBOVAC / TURBOVAC MAG	6
General	
General to TURBOVAC Pumps	6
Applications for TURBOVAC Pumps	12
Accessories for TURBOVAC Pumps	13
Products	
Turbomolecular Pumps with Hybrid (magnetic/mechanical) Rotor Suspension	
General to TURBOVAC i / iX Pumps.	14
with integrated Frequency Converter	22
with integrated Frequency Converter and integrated Vacuum System Controller	22
Special Turbomolecular Pumps.	34
Turbomolecular Pumps with Mechanical Rotor Suspension	
without Compound Stage	36
with or without Compound Stage	
with Frequency Converter for Attaching or Separate	60
with Compound Stage	
with integrated Frequency Converter	64
Turbomolecular Pumps with Magnetic Rotor Suspension	
MAG INTEGRA	
with integrated Frequency Converter	
with and without Compound Stage	68
with separate Frequency Converter	
with Compound Stage	78
Accessories	
Electronic Frequency Converters	
for Turbomolecular Pumps with Mechanical Rotor Suspension	86
for Turbomolecular Pumps with Magnetic Rotor Suspension.	92
Vibration Absorber	96
Air Cooling Unit	
for TURBOVAC ClassicLine Pumps	96
for TURBOVAC SL Pump	97
Flange Heater for CF High Vacuum Flanges	97
Fine Filter	98
Securing Collar for Octal Socket Plugs	98
Solenoid Venting Valve	98
Power Failure Venting Valve.	98
Power Failure Venting Valve, electromagnetically actuated	99
Purge Gas and Venting Valve	99
for ClassicLine and SL Pump	100
Adapter Set for Seal Gas and Venting Valve for the SL pumps	100
Gas Filter to G 1/4" for Purge Gas and Venting Valve.	100
Accessories for Serial Interfaces RS 232 C and RS 485 C	101
Miscellaneous	
Services	102

Oil Diffusion Pumps DIP, LEYBOJET, OB 104

General

Applications and Accessories for Oil Diffusion Pumps 104
Oil for Diffusion Pumps, for different fields of application 105
Oil for Diffusion Pumps, for different pump types 106

Products

DIP Pumps, Water-Cooled 110
LEYBOJET 630, Water-Cooled 114
Oil Booster OB 116

Accessories

Astrotorus Baffles 118
Temperature dependant Switching Components for Automatic Pump System Control 120
Monitoring Instruments 121
Power Controller 122
Adsorption Traps with Aluminium Oxide Insert 124

Cryo Pumps, Cold Heads and Compressor Units

COOLVAC / COOLPOWER / COOLPAK 125

General

Applications and Accessories
 Cryo Pumps 125
 Cryogenics 126
Cryo Pumps 127
Cold Heads 129
Refrigerating Capacity of Cryogenic Cold Heads 131
Compressor Units 132

Products

Cryo Pumps

Cryo Pumps with Fully Automatic Control
 iClassicLine
 COOLVAC 1500 iCL 134
 COOLVAC 2000 iCL, 3000 iCL 136
 COOLVAC 5000 iCL, 10000 iCL 140
 COOLVAC 18000 iCL, 30000 iCL, 60000 iCL 144
Cryo Pumps with Liquid Nitrogen Cooling of Radiation Shield and Baffle of Cryo Pump
 COOLVAC 30000 BL LN₂, 60000 BL LN₂ 147

Cryogenics

Cold Heads
 Pneumatically driven
 Single-Stage Cold Head COOLPOWER 50 and 140 T 150
 Dual-Stage Cold Heads COOLPOWER 7/25, 5/100 and 5/100 T 152
 Mechanically driven
 Single-Stage Cold Head COOLPOWER 250 MD and Dual-Stage Cold Head COOLPOWER 10 MD . 154

Compressor Units	
for pneumatically driven cold heads and pumps	
with water cooling	
COOLPAK 2000/2200	158
COOLPAK 6000 H/6200 H/6000 HD	160
for mechanically driven cold heads and pumps	
with water cooling	
COOLPAK 6000 HMD/6200 HMD	162
General Accessories for Compressor Units COOLPAK	164

Accessories

Cryo Pumps / Cryogenics

Controllers and Monitoring Units for Cryo Pumps.	166
COOLVAC iClassicLine, System Configuration	
Single Operation	170
Dual and Multiple Operation	171
Low Temperature Measurement Instrument MODEL 211S	173
Temperature Sensor	174

General to TURBOVAC Pumps

Turbomolecular vacuum pumps (TURBOVAC) are used in applications which require a clean high or ultrahigh vacuum like, for example, in research, development or in industrial fields like the semiconductor industry, analytical instrumentation or coating technology.

Principle of Operation

In principle, the turbomolecular pump is a turbine rapidly revolving in a housing where the rotor stages of the turbine

are equipped with a number of rotor blades. Located between the rotating rotor blades are stationary stator disks with blades arranged in the opposite direction. By means of a momentum transfer from the rotating rotor blades to the gas molecules their initially non-directional thermal motion is changed in to a directional motion from the inlet flange of the pump in the axial direction towards the forevacuum flange. In the molecular flow range (i.e. at pressures below 10^{-3} mbar (0.75×10^{-3} Torr)) the mean free path of the gas molecules is

larger than the spacing between the rotor and the stator blades (typically a few tenths of a millimetre). Correspondingly the molecules chiefly collide with the optically dense rotor blades, resulting in a highly efficient pumping action. In the laminar flow range (i.e. at pressures over 10^{-1} mbar (0.75×10^{-1} Torr)) the effect of the rotor is impaired by frequent collisions between molecules themselves. For this reason, a turbomolecular pump is not capable of pumping gases at atmospheric pressure.

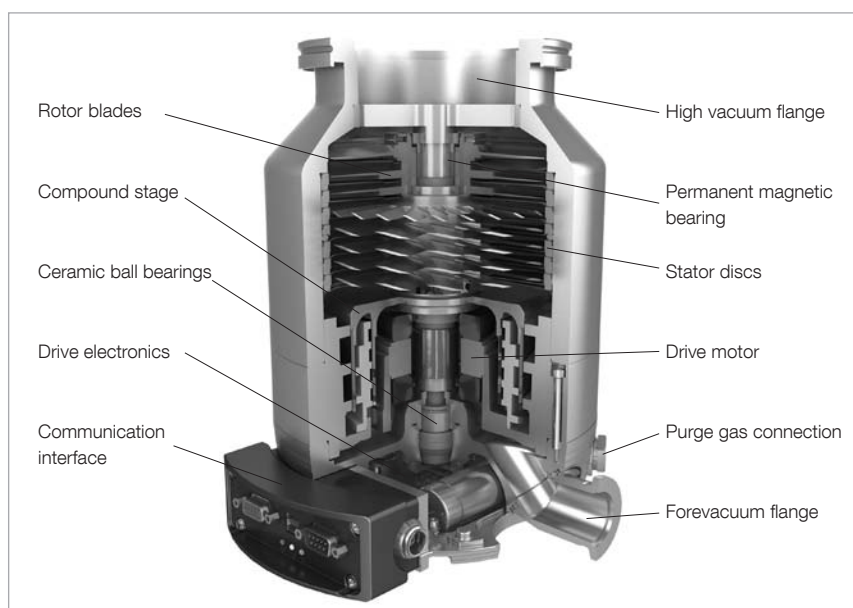

Sectional drawing of a turbomolecular pump (TURBOVAC i)

Rotor Bearing

Leybold offers different rotor bearing systems. A purely classic mechanical type of rotor bearing (TURBOVAC) or a magnetic rotor bearing (TURBOVAC MAG) and also

a hybrid bearing (TURBOVAC i / iX) where the bearing on the forevacuum side is a ceramic ball bearing lubricated for life and where the bearing on the high vacuum side is implemented by way of a non-wearing magnetic bear

ing. Typical for all these types of bearing is that they do not require any lubricating oil which under circumstances like standstill of the pump might diffuse back into the vacuum chamber due to the lack of any pumping action.

Drive Electronics/Control Unit

Driving and monitoring the turbomolecular pump requires an electronic frequency converter (inverter). The frequency converter delivers the driving voltage and the output frequency for the motor and also automatically monitors the system. Optimum running up of the pump rotor is attained by a steadily increasing voltage and frequency feed. After attaining the nominal speed, the start-up current is reduced in a controlled manner to the level necessary for normal operation.

Characteristic Quantities

Pumping speed (volume flow rate)

The pumping speed "S" is the conveyed volume flow through the intake opening of the pump. It is dependent on the type of gas so that for this reason the nominal pumping speed, i.e. the maximum attainable pumping speed of the pump is commonly stated for air, respectively nitrogen. In the field of high vacuum engineering it is common to state the pumping speed in the unit of measurement [l/s]. The pumping speed is a nonlinear function of the inlet pressure $S = S(p_1)$

The frequency converter and the motor of the TURBOVAC have been designed for a minimal drop of speed even at high intake pressures. This ensures the highest possible gas throughput also in the transition range from molecular to viscous flow

Depending on the given system and installation conditions, the control unit may be supplemented by a comprehensive range of optional accessories facilitating easy integration within existing installations.

Gas throughput

Gas throughput "Q", unit of measurement [mbar x l/s] is linked to the pumping speed through the inlet pressure.

$$Q = Q(p_1) = p_1 \times S(p_1).$$

Compression

Compression "K" is defined as the ratio between the pressure on the forevacuum side of the turbomolecular pump and the pressure on the high vacuum side.

$$K = K(p_{VV}) = p_{VV}/p_{HV}$$

Compression is dependent on the type of gas.

Forevacuum Pump

Since turbomolecular pumps are not capable of compressing directly against atmospheric pressure their operation will always require a sufficiently rated forevacuum pump. For the classic rotor arrangement with rotor blades, generally two-stage rotary vane pumps (TRIVAC) will be suitable. In some cases also single-stage rotary vane vacuum pumps (SOGEVAC BI) or scroll vacuum pumps (SCROLLVAC). In the case of the wide range variant where the rotor is equipped with an additional compression stage (compound stage) also diaphragm vacuum pumps (DIVAC) may be used.

Ultimate pressure (base pressure)

The ultimate pressure " p_{ult} " of a turbomolecular pump which can be baked out is defined through the ratio between forevacuum pressure and compression ratio which is attained in a test chamber 48 hours after a 24-hour bake-out (degassing) of the measurement arrangement.

$$p_{ult} = p_{FV}/K_0.$$

The maximum attainable ultimate pressure depends among other things on the cleanliness of the apparatus, the type of forevacuum pump used, the types of seals used for the high vacuum flange and the bake-out conditions.

TURBOVAC Product Line

The TURBOVAC pumps are turbomolecular pumps with mechanical rotor suspension which are used in the pressure range from 10^{-1} mbar (0.75×10^{-1} Torr) to 10^{-10} mbar (0.75×10^{-10} Torr). Pumping speeds for air vary from $35 \text{ l} \times \text{s}^{-1}$ (inlet flange diameter = 40 mm (1.57 in.)) to $1,150 \text{ l} \times \text{s}^{-1}$ (inlet flange diameter = 250 mm (9.84 in.)).

Besides a variant with extremely reliable ceramic ball bearings on the forevacuum and the high vacuum side, Leybold also offers a line of turbomolecular pumps equipped with hybrid bearings which on the forevacuum side are equipped with a ceramic ball bearing and on the high vacuum side with a permanent magnetic bearing (TURBOVAC i line).

Owing to their compact design and ease of operation, these pump lines are

used in all high vacuum and ultrahigh vacuum fields of application. In particular, the TURBOVAC pumps are running very successfully in mass spectrometers, in CD, DVD and hard disk production units, in the manufacture of large area optical coatings, in non-corrosive semiconductor production processes and in laboratories as well as research institutes

The most important advantages of the TURBOVAC product line are:

- Oil-free pumps for the generation of clean high and ultra-high vacuum conditions
- Highest performance in any orientation
- Highest degree of operating reliability
- Easy to operate
- Compact design



TURBOVAC (T) 350 iX

TURBOVAC MAG Product Line

The TURBOVAC MAG pumps are turbomolecular pumps with magnetic rotor suspension which are used in the pressure range from 10^{-1} mbar (0.75×10^{-1} Torr) to 10^{-10} mbar (0.75×10^{-10} Torr). Pumping speeds for air vary from $300 \text{ l} \times \text{s}^{-1}$ (inlet flange diameter = 100 mm (3.94 in.)) to $2,200 \text{ l} \times \text{s}^{-1}$ (inlet flange diameter = 250 mm (12.6 in.)).

The TURBOVAC MAG pumps are mostly installed in areas that require noise-free and vibration-free operation, have to be free of hydrocarbons and require long maintenance intervals. Electron beam microscopy, analytical technology and R & D are also important areas of application for these pumps.

The most important advantages of the TURBOVAC MAG product line are:

- Hydrocarbon-free pumps for the generation of clean high and ultra-high vacuum conditions
- High performance in any orientation
- High degree of operating reliability
- Extremely low vibration
- Almost maintenance-free



TURBOVAC MAG 2200 iPL

Use of Turbomolecular Pumps in Analytical Instruments

All modern analytical methods for gas, liquid and plasma analysis – like for example GC-MS, LC-MS and ICP-MS – rely on mass spectrometers and for this reason require adequate high vacuum conditions. Also in electron microscopes and many surface analysis instruments the production of a high vacuum is essential. In over 90% of all high vacuum applications, the turbomolecular pump has been found to be ideal. Thanks to the hydrocarbon-free vacuum, most simple operation, compact design and almost maintenance-free operation it has in most cases displaced above all the diffusion pump.

On the basis of decades of experience and in cooperation with research facilities and the manufacturers of analytical instruments, Leybold has continually optimized its products.



TURBOVAC MAG W 600 IP

Through the TURBOVAC wide range series, a further improvement has been attained, making available to users in the area of analytical engineering highly flexible and reliable products.

Owing to the modular concept the user may adapt the vacuum system precisely to his requirements. The components can be integrated perfectly and thus find the most cost-effective system configuration. Through the introduction of the TURBOVAC multi inlet series, Leybold has, based on special customer requirements, achieved a major step ahead for analytical instruments.

Two or more analysis chambers can be pumped down simultaneously by a single multi-inlet pump. These pumps have been tailored for pumping speed and gas throughput in order to attain a higher detection sensitivity of analytical systems, for a smaller footprint and an increased sample throughput, for example. The benefits for the customers are the extreme compactness of the vacuum systems without sacrificing performance density, simple installation, stable vacuum connections and, compared to the use of discrete individual pumps, significantly lower investment costs for the entire system. The cartridge solution, moreover, allows for an innovative and cost-effective design of the customer's system and during servicing a simple replacement of the active unit without involved assembly work and leak searching.

Cartridge benefits, which convince

- Higher effective pumping speed
- No losses in conductance
- Compact vacuum system
- Easy pump replacement without having to disassemble the highly sensitive mass spectrometer chambers

The benefits for the customers are reflected by the efficiency of the analytical instruments:

- Increase in detection sensitivity
- Smaller analytical systems
- Increase in sample throughput
- Reduction of system costs
- Lower maintenance costs

In combination with backing pumps like the SOGEVAC, TRIVAC or SCROLLVAC, Leybold is able to offer the best vacuum system optimized for all major applications in the area of analytical instrumentation.



TURBOVAC i Multi Inlet

Use of Turbomolecular Pumps in the Area of Coating Systems

Coating of optical and magnetic storage media, optical components as well as architectural glass requires high vacuum conditions. This is the only way to ensure that the formed layers will be uniform and adhere to the substrate.

The way in which the vacuum is generated has a significant impact on the quality of the coating. By pumping the vacuum chamber down to pressures in the range of 10^{-6} mbar (0.75×10^{-6} Torr), interfering gas and water molecules are removed from the processing chamber. In the case of sputtering the coating process is run in the pressure range between 10^{-3} and 10^{-2} mbar (0.75×10^{-3} and $0.75 \times$

10^{-2} Torr), and in the case of evaporation coating, pressures below 10^{-4} mbar (0.75×10^{-4} Torr) are utilized.

The turbomolecular pump meets all requirements of the customers as to a hydrocarbon-free vacuum, very simple operation, compact design and almost maintenance-free operation in an almost ideal manner. The range of pumps from Leybold includes pumps with flange diameters ranging from 40 mm to 250 mm (1.57 in. to 9.84 in.) nominal width.

Thus the right pump is available for each application, be it coating of data memories (CD, DVD, hard discs), coat

ing of tools and coating of precision lenses in the area of optical components, displays or architectural glass.

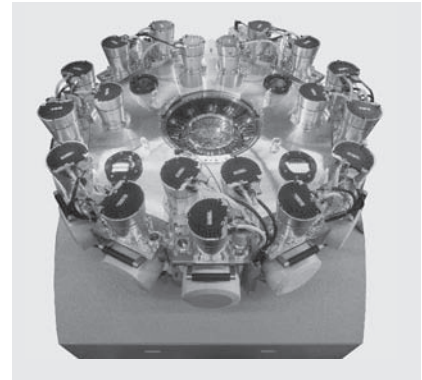

Entire high vacuum equipment of a CD/DVD coating system with TURBOVAC TW 250 S pumps

Use of turbomolecular pumps in research and development

In many applications in which new ideas shall be transformed into technical processes, vacuum technology is a basic requirement for being able to implement these processes at all.

In the field of research and development, all types of turbomolecular pumps from Leybold are being used. Since the application

requirements differ widely, for example are being used. Since the application requirements differ widely, for example between university basic research, industrial development, in research and in large laboratories, the right component or the matching system can be put together from the comprehensive range of equipment being offered.

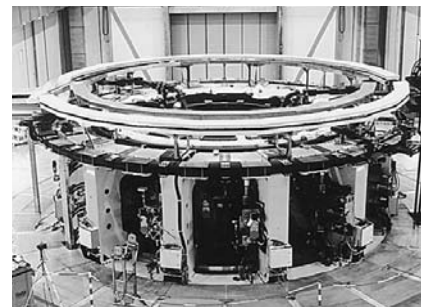

Nuclear fusion technology

Applications for TURBOVAC Pumps

Pumps														
	TURBOVAC 50	TURBOVAC 151, 361 (C)	TURBOVAC 600 C	TURBOVAC 1000 C	TURBOVAC 1100 C	TURBOVAC SL 80	TURBOVAC 90 i, (T) 250/350/450 i	TURBOVAC 90 iX, (T) 250/350/450 iX	MAG W 300/400/600/700 iPL	MAG W 1300/1600/1700/2200 iPL	MAG W 1601/2201 iPL	MAG W 300/400/600/700 P		
Applications														
Analytical Instruments														
Leak detectors	■	■			■	■		■	■			■		■
Mass spectrometers	■	■			■	■		■	■	■			■	■
Gas chromatography (GC-MS)	■	■			■	■		■	■	■			■	■
Liquid chromatography (LC-MS)	■	■			■	■		■	■	■			■	■
Quadrupol time of flight (Q-TOF)						■		■	■	■			■	■
Matrix assisted laser desorption time of flight (MALDI-TOF)	■					■		■	■	■			■	■
Inductively coupled plasma mass spectrometry (ICP-MS)	■					■		■	■	■			■	■
Electron beam microscopy	■				■	■	■		■	■			■	■
Coating														
Data storage / optical		■				■	■		■	■	■	■		■
Data storage / magnetic			■	■	■		■	■		■	■	■	■	■
Flat panel displays			■	■	■				■	■	■	■	■	■
Optical coating		■	■	■	■		■	■		■	■	■	■	■
Large area coating				■	■					■	■			
Decorative coating				■	■		■			■	■			
Metallization				■	■		■			■	■			
Wear protection			■	■	■					■	■			
Metallurgy				■	■					■	■			
R & D (Research and Development)														
Surface analysis				■		■	■		■	■			■	■
UHV / XHV systems		■	■	■	■	■	■	■		■	■		■	■
Particle accelerators		■		■	■					■	■		■	■
Fusion experiments			■	■	■					■	■		■	■
Space simulation			■	■	■					■	■		■	■
Semiconductor Processes														
Load locks and transfer chambers	■	■	■	■	■	■	■	■		■	■	■	■	■
Etch										■	■	■	■	■
PECVD						■				■	■	■	■	■
PVD										■				■
Ion implantation														

Accessories for TURBOVAC Pumps

Pumps	TURBOVAC 50	TURBOVAC 151, 361 (C)	TURBOVAC 600 C	TURBOVAC 1000 C	TURBOVAC 1100 C	TURBOVAC SL 80	TURBOVAC 90 i, (T) 250/350/450 i	TURBOVAC 90 iX, (T) 250/350/450 iX	MAG W 300/400/600/700 iP	MAG W 1300/1600/1700/2200 iP(L)	MAG W 300/400/600/700 P
Accessories											
Integrated Frequency Converter						■	■	■	■	■	■
External Frequency Converter				■							
External Frequency Converter and Power Supply	■	■	■	■	■						■
Power Supply				■	■	■	■	■			
Mounting Kit		■	■			■	■	■			
Inlet screen / Splinter guard				■	■	■	■	■	■	■	■
Vibration absorber	■	■	■	■	■	■	■	■			■
Air cooling unit	■	■	■	■	■	■	■	■			■
Water cooling kit	■				■	■	■	■	■		■
Flange heaters for CF flanges	■	■	■	■	■	■	■	■			■
Venting valve	■	■	■	■	■	■		■			■
Purge gas valve					■	■	■	■	■	■	■
Purge gas and venting valve		■	■	■	■				■	■	
Power failure venting valve		■	■	■	■	■	■	■	■	■	■
Electronic brake module								■			■
Relais box						■	■	■			
Accessories for serial interfaces		■	■	■	■	■	■	■	■	■	■
Control Software for TURBOVAC		■	■	■	■	■	■	■	■	■	■

High Vacuum Pumps

General to TURBOVAC i / iX Pumps

Turbomolecular Pumps with Hybrid Rotor Suspension (mechanical/magnetic)

TURBOVAC i, iX / T i, T iX

The TURBOVAC i / iX series is a modular line of turbomolecular vacuum pumps. With the integrated drive electronics (frequency converter) it forms a single unit.

In the development of the TURBOVAC i / iX special emphasis was placed on the maximum attainable pump performance in consideration of its footprint. The specially developed rotor/stator design, upon request with an additional compression stage, guarantees excellent performance data as to pumping speed, gas throughput and compression especially also for light gases.

In all pumps of this line, the bearing consists of a non-wearing permanent magnetic bearing on the high vacuum side and an oil-free ceramic ball bearing which is lubricated for life on the forevacuum side. For this reason, the usually required standard maintenance involving an oil change is no longer necessary. The ceramic ball bearing is replaceable on-site, should this be required.

The pumps are equipped as standard with a venting and purge gas facility for directly connecting a venting valve, purge gas valve or purge gas throttle to the pump.

Owing to the many possible combinations (electronics, pump stage design, housing and the range of accessories) the TURBOVAC i / iX can be flexibly adapted to the specific application in each case.

For example, in comparison with the TURBOVAC i, the TURBOVAC iX is equipped with an integrated vacuum system control unit which drives accessory components like vacuum gauge, valves, fans and forevacuum pumps. Moreover, numerous optionally available communication interfaces facilitate easy integration within your installation.

The pump stage design (rotor, stator and Holweck stage) can be selected specifically in consideration of the respective process requirements and offers variants for highest possible gas throughput, pumping speed and/or compression in single or multi-chamber systems. Equally comprehensive is the range of housing and flange variants being offered where the vacuum connections can be adapted flexibly to the on-site installation conditions. The comprehensive range of accessories completes the TURBOVAC i / iX line thereby extending the fields of application for these pumps.

Advantages to the User

- High pumping performance from a compact size
- Cost-effective price-to-performance ratio
- Highly reliable, maintenance-free bearing concept without oil lubrication
- Owing to the overall modular concept, individually adaptable to the respective conditions and requirements
- Variety of housings and flange options
- Easy and easily adaptable installation, any mounting position
- Easy process integration due to the numerous interfacing options
- Flexible accessory options (power supply, cooling, heating, venting, installation etc.)

Overview of Variants

Electronics Variants

All pumps are equipped with integrated drive electronics with a 24 V/48 V power supply which controls the amount of drive power and which monitors all pump functions.

The individual requirements with regard to communication interfaces and the functional scope of the driving options for accessory components can be covered through a number of different electronics variants.



Left: TURBOVAC i with standard interface

Centre: **TURBOVAC i** with Anybus interface extension

Right: **TURBOVAC iX** with integrated vacuum system control unit and Anybus interface extension

Electronics Variants

TURBOVAC i (Standard)

Cost-effective solution equipped with basic functions and interfaces.

- Internal 24/48 V DC frequency converter
- Status LEDs
- Accessory connection for up to 2 controllable accessory components
- User-friendly interfaces (USB, RS 485, 15-pin digital I/O)



Standard interface USB, RS 485 and 15-pin digital I/O for TURBOVAC i

TURBOVAC i (Anybus interface extension)

Features like TURBOVAC I, additionally:

- User-friendly interfaces (USB, 15-pin digital I/O) and Anybus interface instead of the RS 485 for further interface options: RS 232, Profibus, Ethernet/IP (further interfaces upon request)

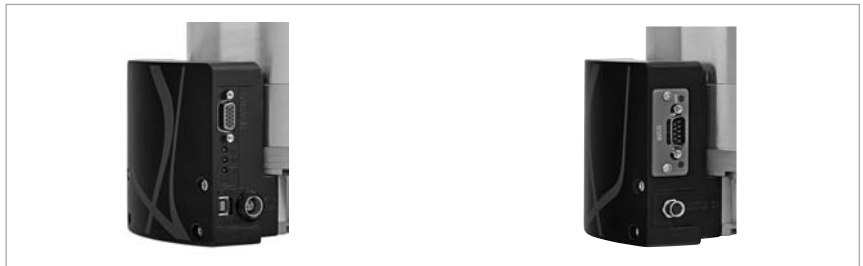

Anybus interface expansion for TURBOVAC i

TURBOVAC iX (Vacuum system control unit)

With integrated vacuum system control unit and Anybus interface extension.

Features like TURBOVAC i (Anybus interface extension), additionally:

- 3 outputs for controlling vacuum pump accessories
- 1 vacuum gauge head connection for powering and data recording of vacuum gauge heads and application of pressure data for pump system control
- Flexibly programmable software, for customising the configuration of the control connections



Integrated vacuum system control unit of the TURBOVAC iX

Performance Variants



TURBOVAC i, iX

The standard variant for UHV applications and compact pump system solutions. Owing to the additional Holweck compression stage it delivers a high pumping speed and a high compression especially for light gases, and due to its high forevacuum tolerance it is suited for operation in connection with diaphragm or scroll forevacuum pumps.



TURBOVAC T i, T iX

The "T" version with its classic rotor design without additional compression stage is suited for deployment under more stringent process conditions and high gas loads. Compared to the standard variant it stands for faster run-up times, increased gas throughput and an improved tolerance with regard to pumping of particle or dust containing media.



TURBOVAC i Multi-Inlet

The variant with a special rotor design and two or more inlets as an efficient and compact vacuum solution for multi-chamber systems. It allows for a high degree of system integration and convinces compared to systems with discrete turbomolecular pumps through its lower weight and smaller footprint as well as an increased reliability of the entire vacuum system through the reliance on fewer components compared to similar systems equipped with discrete turbomolecular pumps.

Housing and Flange Variants

The optimised rotor geometry has been specially adapted to the industrial standard sizes for maximum pump performance. Housings with ISO-K as well as CF flanges are available. Moreover, the standard housings with an additional inlet stage are available upon request.

Multiple inlet stages can be implemented through the **TURBOVAC Multi-Inlet**. Here in addition to the special cartridge solution which facilitates easy replacement in the field, also custom housing and chamber solutions are offered for utmost system integration.

Flexibility

The forevacuum connection on all pumps is rotatable thereby facilitating flexible installation within existing systems making optimum use of the available space. Moreover, the required amount of installation space may be reduced by a detachable cable connected interface module



Left: TURBOVAC i with radial forevacuum flange
Right: TURBOVAC i with axial forevacuum flange

Accessories for TURBOVAC i, iX / T i, T iX

Power Supply

TURBO.POWER integra

- Plug-and-play power supply for fitting underneath the pump, 100-240 V
 - for TURBOVAC (T) 350 i(X) and TURBOVAC (T) 450 i(X) only
- Including short connecting cable to the pump
- Also for benchtop placement (TURBOVAC 90/250/350/450) with optional extension cable (1, 3, 5 m (3.5, 10.5, 17.5 ft))
- Requires a country-specific mains cord (EU, US, UK ...)



Pump control unit with Power Supply TURBO.CONTROL 300

- Control unit and power supply for rack installation
- With on/off switch for the turbo-molecular pump
- Status LEDs and status relays for monitoring the pump
- For remote control via interface
- Requires a connection cable to the pump (1, 3, 5 m (3.5, 10.5, 17.5 ft)) and country-specific mains cord (EU, US, UK ...)

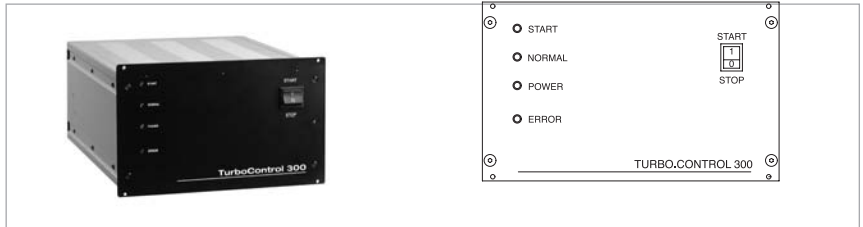

Connecting cables to the pump with bare wire ends of for customer specific power supply units



Relay Box

The relay box allows you to control via the 24 V DC output on the TURBOVAC i a mains powered electric consumer, like a backing pump, for example. Mains power and consumer are connected using mains power cords, the control voltage is connected through an M 8 connector.

- incl. connection cable with a M 8 plug, 2 m (7.0 ft) long



DC Pump Plug

for adapting the supply voltage by the customer.

- 24/48 V DC-In plug TURBOVAC i



Radial air cooler

for lateral installation on the pump, including connection plug

- Flexible positioning



Axial air cooler

For installation underneath the pump, including connection plug



Water cooling

for flexible installation on the pump (required for degassing the turbomolecular pump)



Heating Collar

for degassing the pump

- Degassing temperature 100 °C (212 °F)
- Requires a country-specific mains cord (EU, US, UK ...)
- With optional relay box and accessory cable, automatic control via the electronics of the TURBOVAC i / iX is possible



Accessory Valves

- Power supply 24 V DC
- G 1/8" inlet (inside thread) and discharge (outside thread) connection
- Including O-ring and connecting cable with M 8 plug for connection to the accessory input on the TURBOVAC i / iX

Purge Gas Valve (for connection to the purge gas connection on the turbomolecular pump)

for controlling the admitted purge gas quantity

- The valve is closed when no power

Venting Valve (for connection the venting connection)

for venting the turbomolecular pump

- The valve is normally closed

Power Failure Venting Valve (for connection the venting connection)

for venting the turbomolecular pump

- The valve is normally open

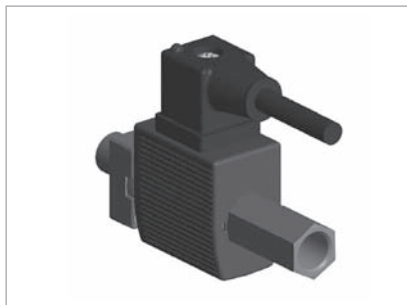

Purge Gas Throttle

for passively controlling the admitted purge gas quantity

- G 1/8" inlet (inside thread) and discharge (outside thread) connection
- Purge gas throttle 24 sccm



Air Filter

for connection to the valves or throttles

- Prevents contamination and clogging of valves and throttles
- G1/8"

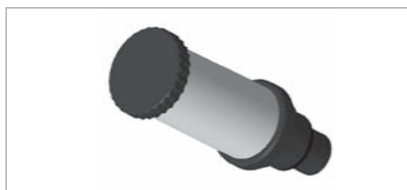

Y-Splitter

- Extends the M 8 accessory connection on the TURBOVAC i by a further connection for parallel driving of two accessory components. Here both accessory components are switched synchronously

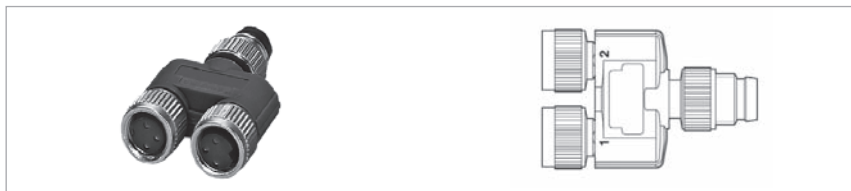

Installation and Mounting Accessories

Mounting kit for safe mounting of the pump

The mounting kits include:

ISO-K kit (100 und 160):

centering rings and clamps

ISO-F kit (100 und 160):

collar flange, outside ring, bolts and nuts

CF kit (100 und 160):

2 copper gaskets, bolts, nuts and washers



Mounting kits (left ISO-KF, centre ISO-F, right CF)

Centering Rings with Splinter Guard (DN 100 and 160 ISO-K/F)

Centering Rings with Inlet Screens (DN 100 and 160 ISO-K/F)

Splinter Guards (DN 100 und 160 CF)

Inlet Screens (DN 100 und 160 CF)

for protecting the pump against ingesting parts.

Inlet screen, 3.2 mm (0.01 ft) mesh

Splinter guard, 0.8 mm (0.003 ft) mesh

Note:

For ISO-K/F, both inlet screen and splinter guard have been integrated in the centering ring.



Vibration Absorber

(DN 100/160 ISO-K and 100/160 CF)

Prevents any possible vibration transfer from the pump to sensitive instrumentation or apparatus.



Software LEYASSIST *

Software for PC-based communication, control and monitoring of turbomolecular pumps via USB, RS 485 or RS 232 interface with automatic pump detection.

Functions

- Display of vacuum system status
- Trend configuration and report
- Configuring the accessory functions of the TURBOVAC i / iX
- Reading/writing of parameters
- Data logging
- Alarm/warning message logging
- Interface uses USB (with USB cable 2.0, Type A/B, 1.8 m (6.3 ft) long), RS 485 or RS 232 (with dongle)
 - Functions: reading/writing of parameters, control and data acquisition
- Automatic detection of connected Leybold pump type or instrument
- Different languages and with different user access levels are available

* included in delivery of TURBOVAC iX

Ordering Information

Software LEYASSIST for turbomolecular vacuum pumps

Part. No. 230439V01



Products

TURBOVAC
with Hybrid Rotor Suspension (mag/mech)

with integrated Frequency Converter

TURBOVAC 90 i, 250 i, (T) 350 i and (T) 450 i



TURBOVAC 90 i (left), 250 i (T), 350 i and (T) 450 i (right)

with integrated Frequency Converter and
integrated Vacuum System Controller

TURBOVAC 90 iX, 250 iX, (T) 350 iX and (T) 450 iX



TURBOVAC 90 iX (left), 250 iX, (T) 350 iX and (T) 450 iX (right)

Typical Applications

- Analytical technologies / Research & Development
- Mass spectrometers
- Electron microscopes
- Surface analysis
- X-ray-analysis
- Particle accelerators and synchrotrons
- Laboratory coating systems
- MBE (Molecular Beam Epitaxy)
- UHV systems
- Life Sciences
- Proton therapy
- Gamma sterilisation
- Production of high quality implants
- Industrial and Coating applications
- PVD- Physical Vapour deposition
- Optical coatings
- CD/DVD/Blu-Ray Disc production
- Thin film technologies, photovoltaics
- Load locks, transfer chambers, handling systems
- Electron beam welders
- Insulation vacuum and leak detection

Technical Features

TURBOVAC i

- Integrated electronic drive unit with 24/48 V DC supply
- Best in class pumping speed and compression especially for light gases
- Vacuum port design flexibility
- Installation in any orientation
- Superior reliability due to innovative pump and bearing design
- The only maintenance free hybrid mechanical TMP
- no need for oil changes
- On-site maintenance possibility (bearing exchange) to reduce service costs and time
- Widest range of interface options (USB, RS 485 and 15 pin digital I/O as standard)
- Optimized size/performance ratio on 100 and 160 flanges

TURBOVAC iX

- Integrated vacuum system controller with flexible interfaces and several accessory ports for control of cooling units, valves, gauges, forevacuum pumps etc.
- Flexible accessory program options for easy plug & play
- Flexibility to match different process and application requirements

TURBOVAC T i, T iX

- Variant without Compound Stage
- increased gas throughput
- Increased tolerance against dust and particles
- Improved run-up time

Advantages to the User

TURBOVAC i

- Best performance and functionality for your money
- Maximum user flexibility for easy system integration, operation and control
- Highest productivity and system uptime at lowest CoO (Cost of Ownership)
- Improved pump-down time and target pressures
- Superior pumping performance for light gases
- Down-sizing of vacuum system in terms of costs and dimensions (use of small forevacuum pumps)

TURBOVAC iX

- Easy plug & play pump system control
- Avoid extra costs for separate pump system control units and cabling

TURBOVAC T i, T iX

- Suitable for demanding process applications and high throughput operation
- Fast cycle operation and pump down possible

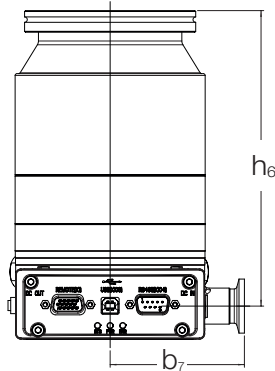
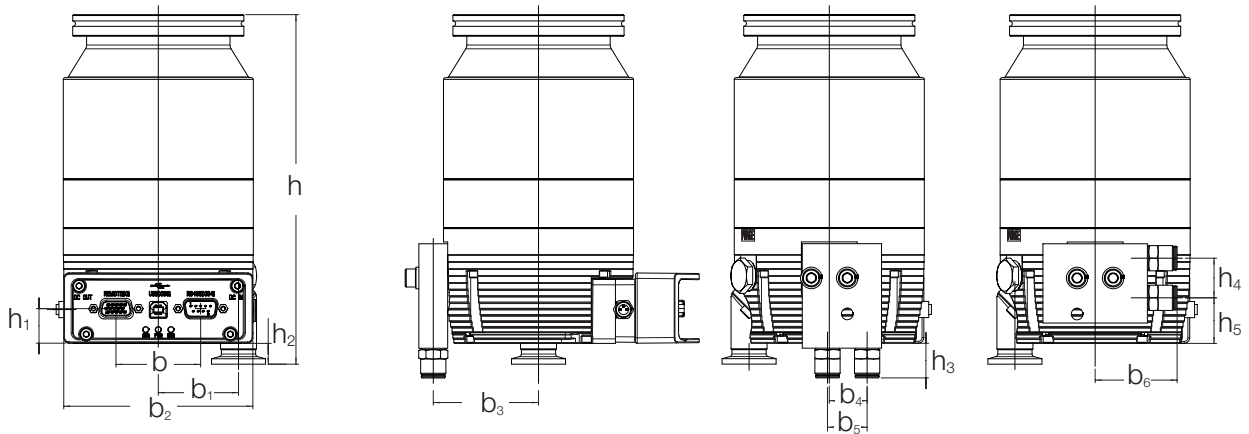

Typ	DN		a	a ₁	b	b ₁	b ₂	b ₃	b ₄
TURBOVAC 90 i	ISO-K	mm (in.)	-	-	47 (1.85)	45 (1.77)	105 (4.13)	58 (2.28)	21 (0.83)
	CF	mm (in.)	-	-	47 (1.85)	45 (1.77)	105 (4.13)	58 (2.28)	21 (0.83)
TURBOVAC 250 i	ISO-K	mm (in.)	49 (1.93)	47 (1.85)	20 (0.79)	75 (2.95)	81 (3.19)	89 (3.50)	47 (1.85)
	CF	mm (in.)	49 (1.93)	-	20 (0.79)	75 (2.95)	81 (3.19)	89 (3.50)	47 (1.85)
	DN		b ₅	b ₆	b ₇	d	d ₁	h	h ₁
TURBOVAC 90 i	ISO-K	mm (in.)	22 (0.87)	46 (1.81)	75 (2.95)	110 (4.33)	-	194 (7.64)	19 (0.75)
	CF	mm (in.)	22 (0.87)	46 (1.81)	75 (2.95)	110 (4.33)	-	194 (7.64)	19 (0.75)
TURBOVAC 250 i	ISO-K	mm (in.)	105 (4.13)	54 (2.13)	57 (2.24)	130 (5.12)	131 (5.16)	196 (7.32)	19 (0.75)
	CF	mm (in.)	105 (4.13)	54 (2.13)	52 (2.05)	151.5 (5.96)	131 (5.16)	205 (8.07)	19 (0.75)
	DN		h ₂	h ₃	h ₄	h ₅	h ₆	h ₇	
TURBOVAC 90 i	ISO-K	mm (in.)	12 (0.47)	19 (0.75)	22 (0.87)	25 (0.98)	164 (6.46)		
	CF	mm (in.)	12 (0.47)	19 (0.75)	22 (0.87)	25 (0.98)	164 (6.46)		
TURBOVAC 250 i	ISO-K	mm (in.)	36 (1.41)	39 (1.54)	19 (0.75)	38 (1.50)	19 (0.75)		
	CF	mm (in.)	36 (1.41)	39 (1.54)	19 (0.75)	38 (1.50)	19 (0.75)		

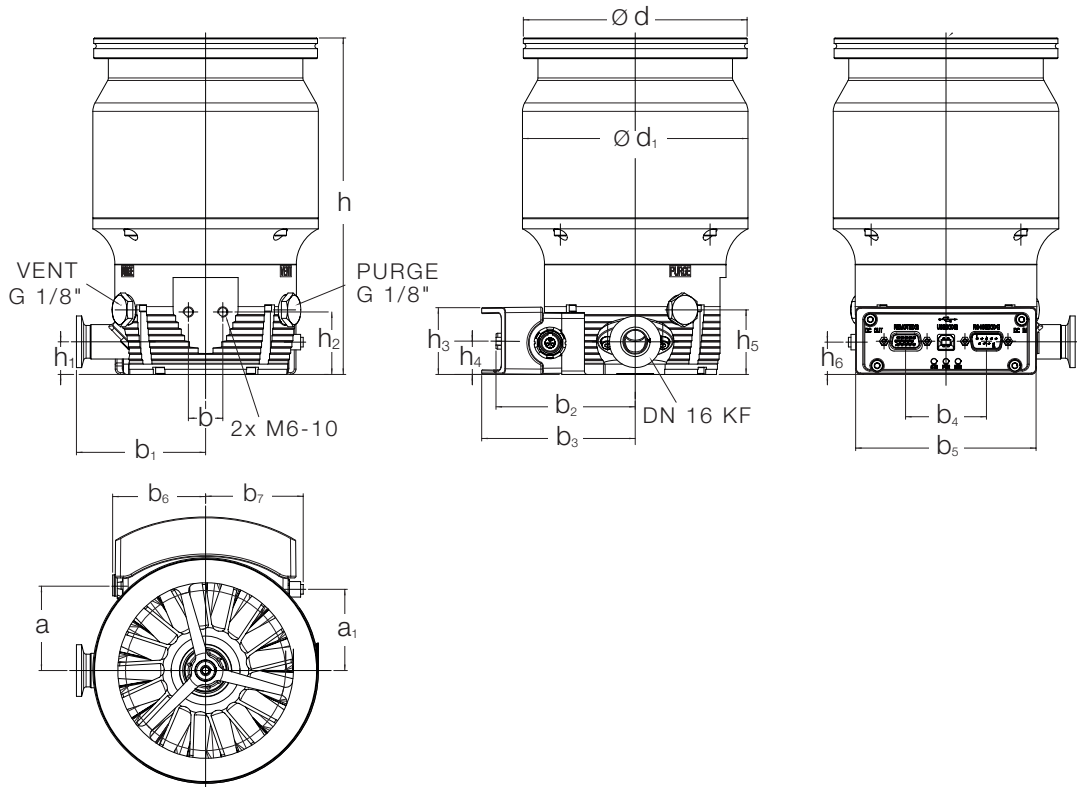

Dimensional drawing for the TURBOVAC pumps, 90 i top and 250 i bottom

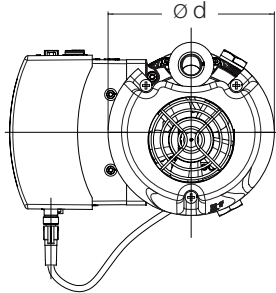
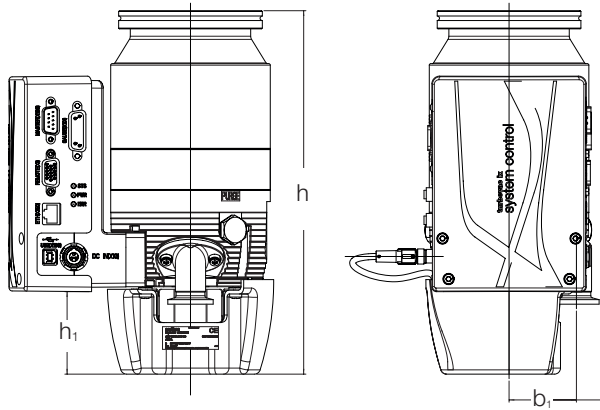

Typ	DN		a	a ₁	a ₂	b	b ₁	b ₂	b ₃
TURBOVAC 90 IX	ISO-K	mm (in.)	-	-	-	-	45 (1.77)	-	-
	CF	mm (in.)	-	-	-	-	45 (1.77)	-	-
TURBOVAC 250 IX	ISO-K	mm (in.)	92 (3.62)	75 (2.95)	93 (3.66)	20 (0.79)	75 (2.95)	120 (4.72)	110 (4.33)
	CF	mm (in.)	92 (3.62)	75 (2.95)	93 (3.66)	20 (0.79)	75 (2.95)	120 (4.72)	110 (4.33)
	DN		d	d ₁	h	h ₁	h ₂	h ₃	h ₄
TURBOVAC 90 IX	ISO-K	mm (in.)	110 (4.33)	-	240 (9.45)	55 (2.16)	-	-	-
	CF	mm (in.)	110 (4.33)	-	240 (9.45)	55 (2.16)	-	-	-
TURBOVAC 250 IX	ISO-K	mm (in.)	130 (5.12)	131 (5.16)	196 (7.72)	19 (0.75)	36 (1.42)	199 (7.83)	57 (2.24)
	CF	mm (in.)	151,5 (5.96)	131 (5.16)	205 (8.07)	19 (0.75)	36 (1.42)	208 (8.19)	66 (2.60)
	DN		h ₅	h ₆	h ₇	h ₈	h ₉		
TURBOVAC 90 IX	ISO-K	mm (in.)	-	-	-	-	-	-	-
	CF	mm (in.)	-	-	-	-	-	-	-
TURBOVAC 250 IX	ISO-K	mm (in.)	38 (1.50)	64 (2.52)	47 (1.85)	23 (0.91)	23 (0.91)		
	CF	mm (in.)	38 (1.50)	64 (2.52)	47 (1.85)	23 (0.91)	23 (0.91)		

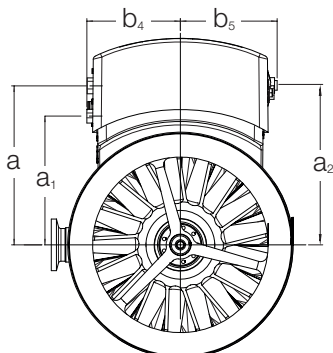
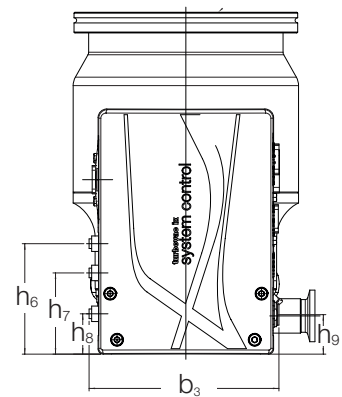
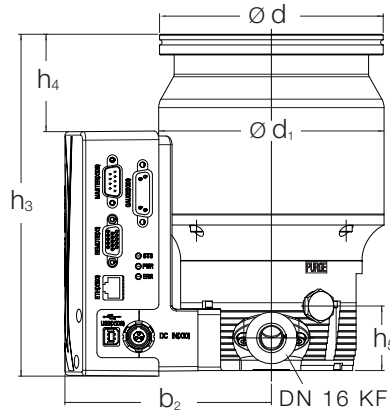
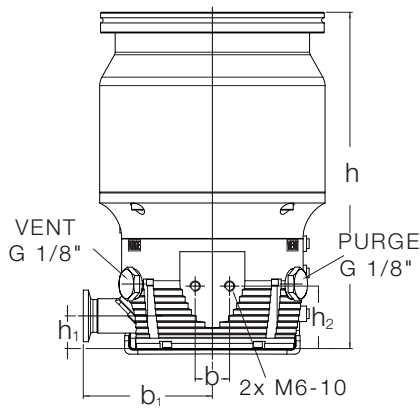

Dimensional drawing for the TURBOVAC pumps, 90 IX top and 250 IX bottom

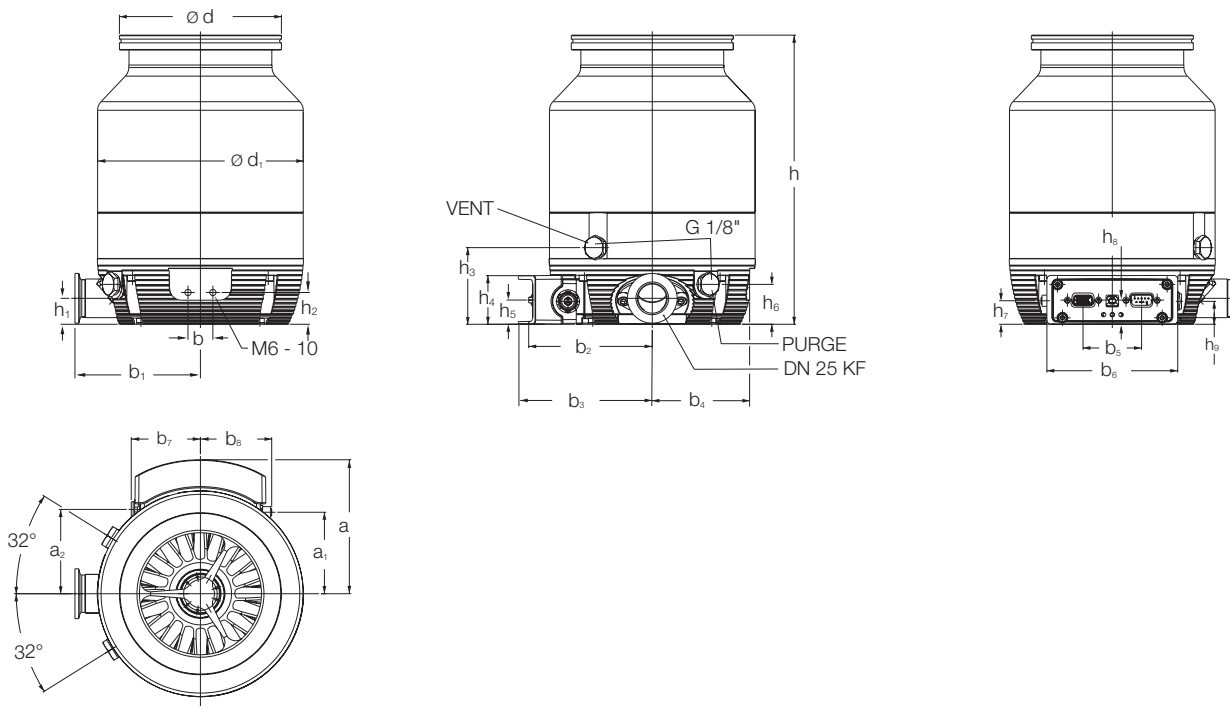

Type	DN		a	a ₁	a ₂	b	b ₁	b ₂	b ₃	b ₄
TURBOVAC (T) 350 i	ISO-K	mm (in.)	107.5 (4.23)	65.4 (2.57)	67.6 (2.66)	20 (0.79)	100.7 (3.96)	99.2 (3.91)	107.5 (4.23)	78.1 (3.07)
	CF	mm (in.)	107.5 (4.23)	65.4 (2.57)	67.6 (2.66)	20 (0.79)	100.7 (3.96)	99.2 (3.91)	107.5 (4.23)	78.1 (3.07)
TURBOVAC (T) 450 i	ISO-K	mm (in.)	107.5 (4.23)	65.4 (2.57)	67.6 (2.66)	20 (0.79)	100.7 (3.96)	99.2 (3.91)	107.5 (4.23)	78.1 (3.07)
	CF	mm (in.)	107.5 (4.23)	65.4 (2.57)	67.6 (2.66)	20 (0.79)	100.7 (3.96)	99.2 (3.91)	107.5 (4.23)	78.1 (3.07)
	DN		b ₅	b ₆	b ₇	b ₈	d	d ₁	h	h ₁
TURBOVAC (T) 350 i	ISO-K	mm (in.)	47 (1.85)	105 (4.13)	55.5 (2.19)	57.2 (2.25)	130 (5.12)	165 (6.5)	232 (9.13)	20.8 (0.82)
	CF	mm (in.)	47 (1.85)	105 (4.13)	55.5 (2.19)	57.2 (2.25)	180 (7.09)	165 (6.5)	245 (9.65)	20.8 (0.82)
TURBOVAC (T) 450 i	ISO-K	mm (in.)	47 (1.85)	105 (4.13)	55.5 (2.19)	57.2 (2.25)	130 (5.12)	165 (6.5)	216 (8.5)	20.8 (0.82)
	CF	mm (in.)	47 (1.85)	105 (4.13)	55.5 (2.19)	57.2 (2.25)	180 (7.09)	165 (6.5)	222 (8.74)	20.8 (0.82)
	DN		h ₂	h ₃	h ₄	h ₅	h ₆	h ₇	h ₈	h ₉
TURBOVAC (T) 350 i	ISO-K	mm (in.)	25.5 (1.0)	61.5 (2.42)	39 (1.54)	19.4 (0.76)	32 (1.26)	19 (0.75)	18.8 (0.74)	18.4 (0.72)
	CF	mm (in.)	25.5 (1.0)	61.5 (2.42)	39 (1.54)	19.4 (0.76)	32 (1.26)	19 (0.75)	18.8 (0.74)	18.4 (0.72)
TURBOVAC (T) 450 i	ISO-K	mm (in.)	25.5 (1.0)	61.5 (2.42)	39 (1.54)	19.4 (0.76)	32 (1.26)	19 (0.75)	18.8 (0.74)	18.4 (0.72)
	CF	mm (in.)	25.5 (1.0)	61.5 (2.42)	39 (1.54)	19.4 (0.76)	32 (1.26)	19 (0.75)	18.8 (0.74)	18.4 (0.72)

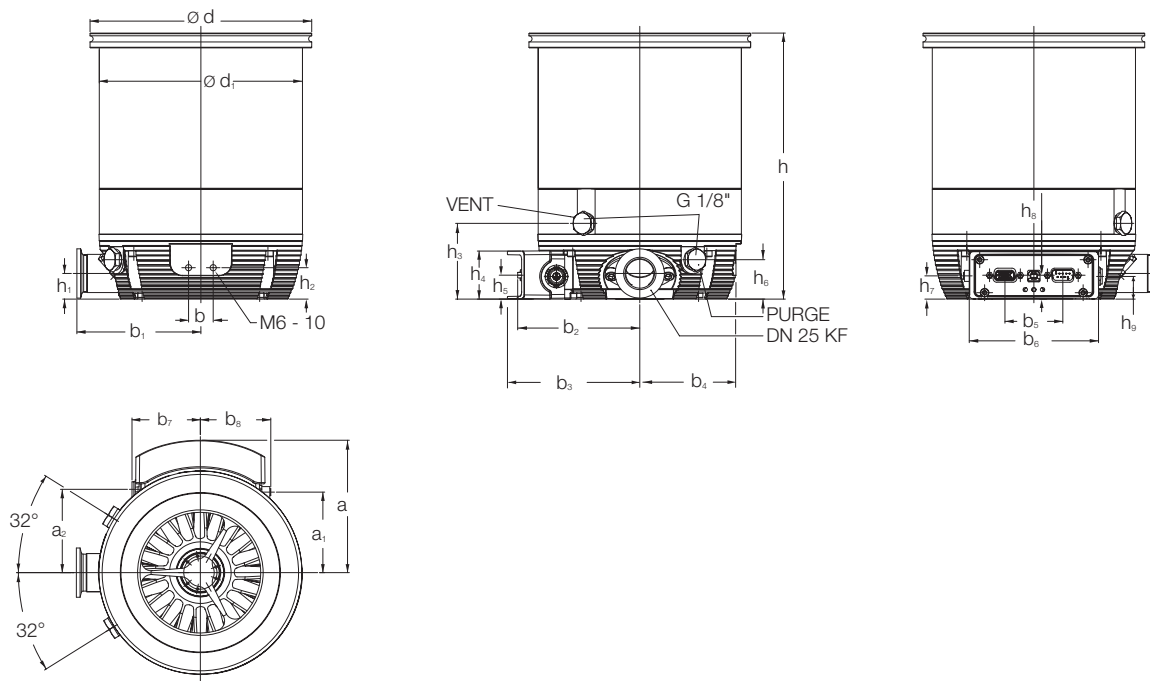

Dimensional drawing for the TURBOVAC (T) pumps, 350 i top and 450 i bottom

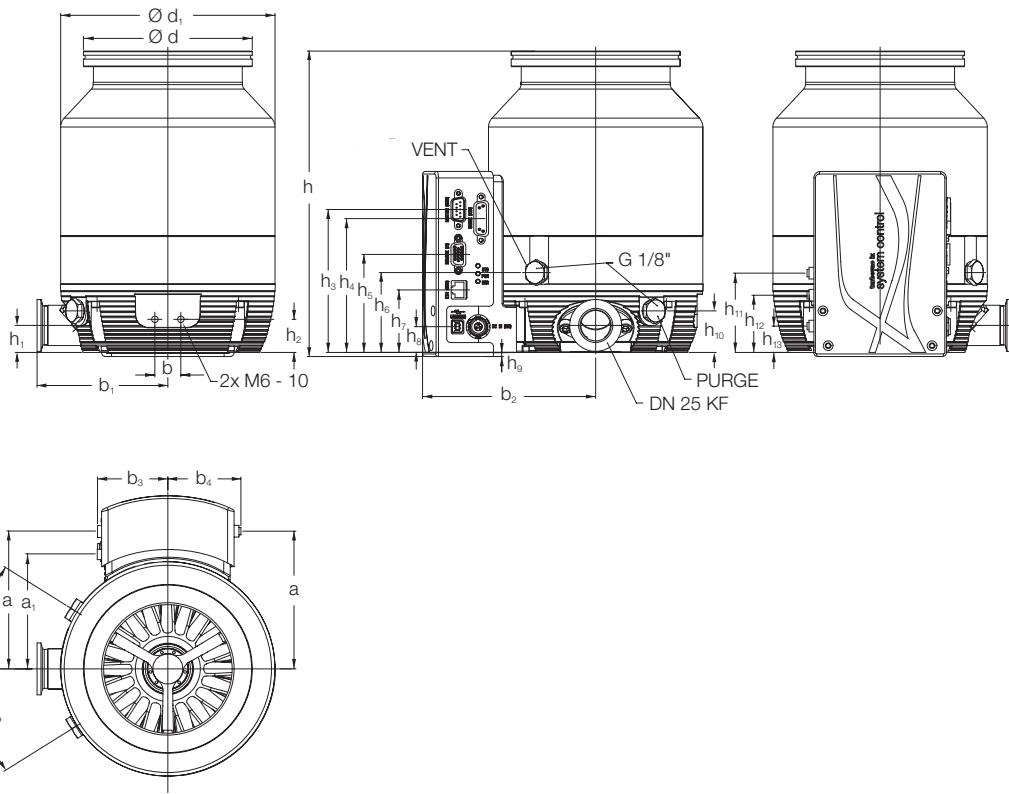

Type	DN		a	a ₃	b	b ₁	b ₂	b ₃	b ₄	
TURBOVAC (T) 350 IX	ISO-K	mm (in.)	111 (4.37)	78 (3.07)	20 (0.79)	101 (3.98)	138 (5.43)	54 (2.13)	56 (2.2)	
	CF	mm (in.)	111 (4.37)	78 (3.07)	20 (0.79)	101 (3.98)	138 (5.43)	54 (2.13)	56 (2.2)	
TURBOVAC (T) 450 IX	ISO-K	mm (in.)	111 (4.37)	78 (3.07)	20 (0.79)	101 (3.98)	138 (5.43)	54 (2.13)	56 (2.2)	
	CF	mm (in.)	111 (4.37)	78 (3.07)	20 (0.79)	101 (3.98)	138 (5.43)	54 (2.13)	56 (2.2)	
	DN		d	d ₁	h	h ₁	h ₂	h ₃	h ₄	h ₅
TURBOVAC (T) 350 IX	ISO-K	mm (in.)	130 (5.12)	165 (6.5)	235 (9.25)	21 (0.83)	26 (1.02)	110 (4.33)	103 (4.06)	76 (2.99)
	CF	mm (in.)	180 (7.09)	165 (6.5)	248 (9.76)	21 (0.83)	26 (1.02)	110 (4.33)	103 (4.06)	76 (2.99)
TURBOVAC (T) 450 IX	ISO-K	mm (in.)	130 (5.12)	165 (6.5)	219 (8.62)	21 (0.83)	26 (1.02)	110 (4.33)	103 (4.06)	76 (2.99)
	CF	mm (in.)	180 (7.09)	165 (6.5)	225 (8.86)	21 (0.83)	26 (1.02)	110 (4.33)	103 (4.06)	76 (2.99)
	DN		h ₆	h ₇	h ₈	h ₉	h ₁₀	h ₁₁	h ₁₂	h ₁₃
TURBOVAC (T) 350 IX	ISO-K	mm (in.)	62 (2.44)	48 (1.89)	20 (0.79)	3 (0.12)	32 (1.26)	64 (2.52)	47 (1.85)	23 (0.91)
	CF	mm (in.)	62 (2.44)	48 (1.89)	20 (0.79)	3 (0.12)	32 (1.26)	64 (2.52)	47 (1.85)	23 (0.91)
TURBOVAC (T) 450 IX	ISO-K	mm (in.)	62 (2.44)	48 (1.89)	20 (0.79)	3 (0.12)	32 (1.26)	64 (2.52)	47 (1.85)	23 (0.91)
	CF	mm (in.)	62 (2.44)	48 (1.89)	20 (0.79)	3 (0.12)	32 (1.26)	64 (2.52)	47 (1.85)	23 (0.91)

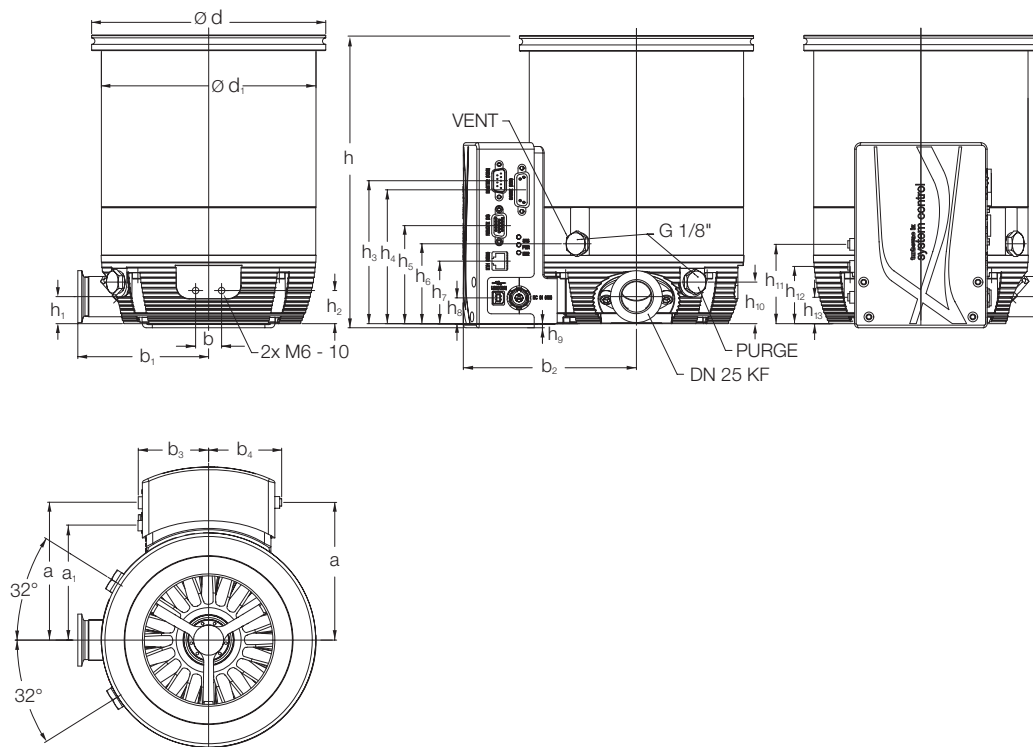

Dimensional drawing for the TURBOVAC (T) pumps, 350 IX top and 450 IX bottom

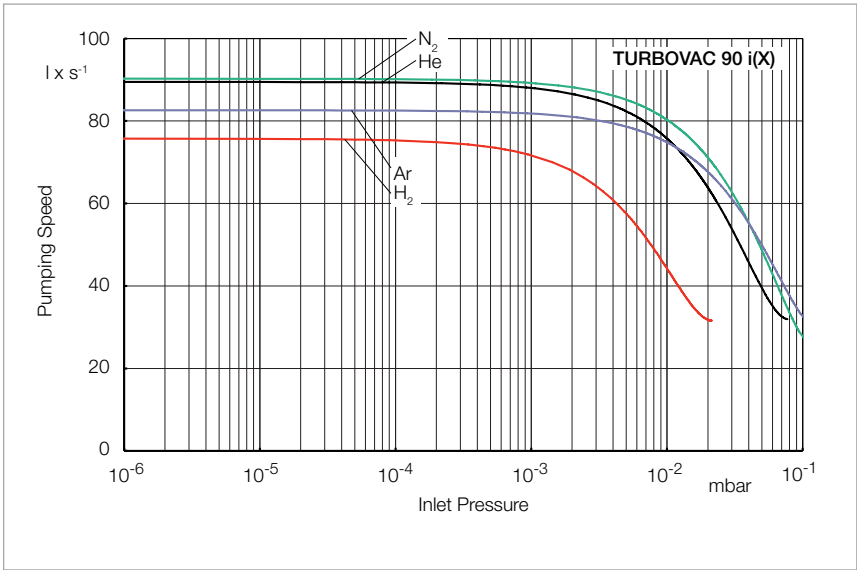

Pumping speed as a function of the inlet pressure for the TURBOVAC 90 i

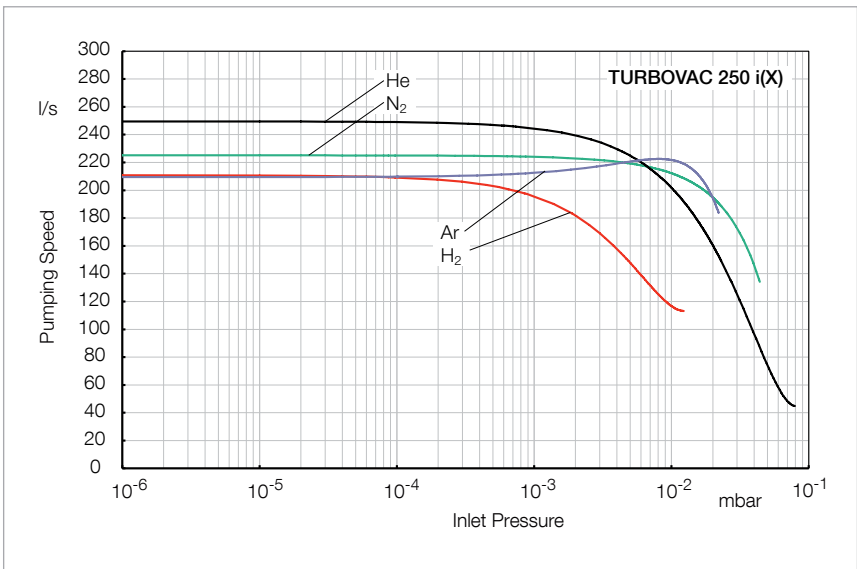

Pumping speed as a function of the inlet pressure for the TURBOVAC 250 i

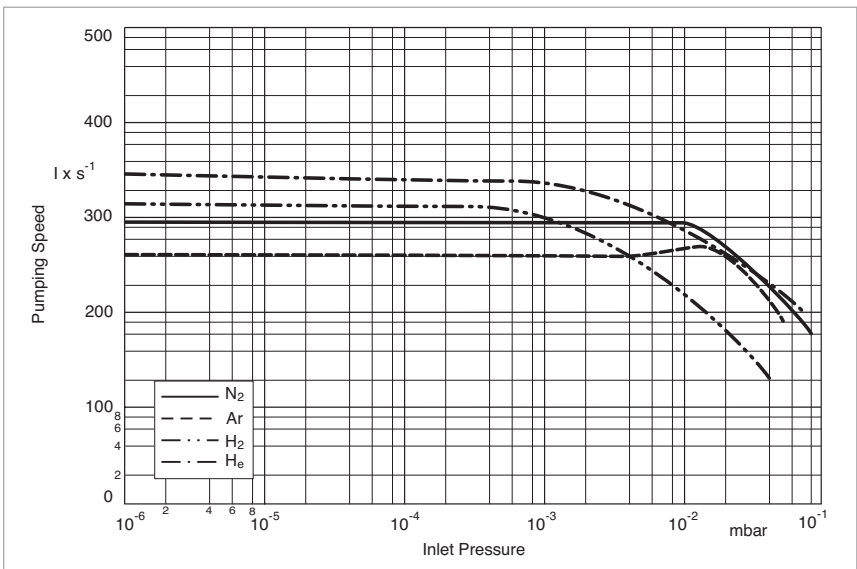

Pumping speed as a function of the inlet pressure for the TURBOVAC 350 i

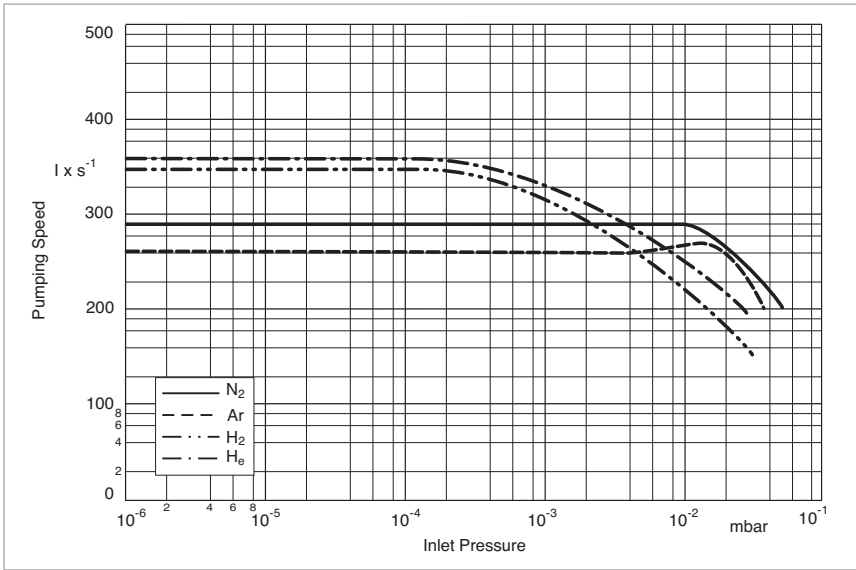

Pumping speed as a function of the inlet pressure for the TURBOVAC T 350 i

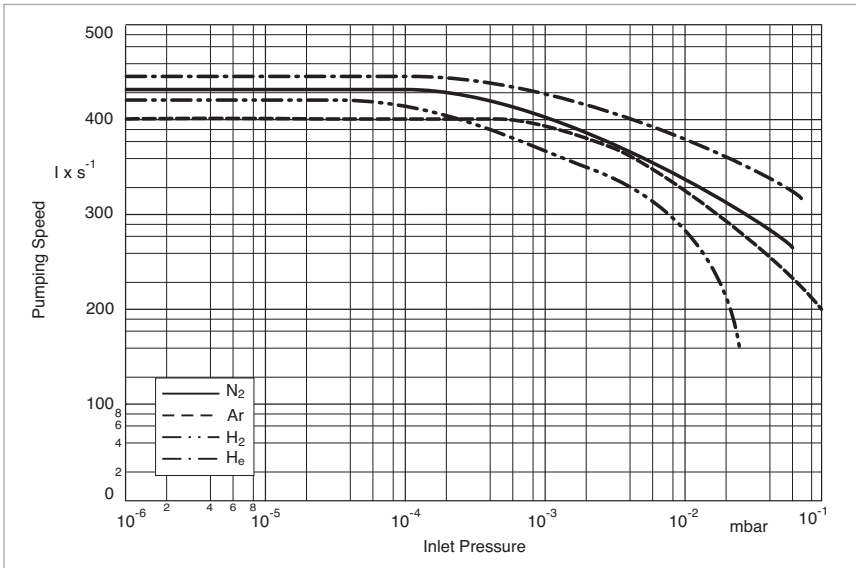

Pumping speed as a function of the inlet pressure for the TURBOVAC 450 i

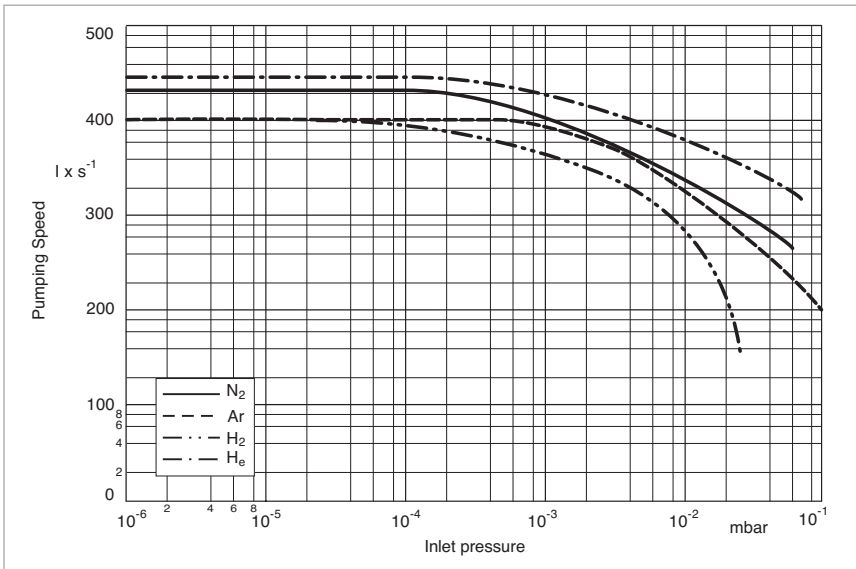

Pumping speed as a function of the inlet pressure for the TURBOVAC T 450 i

Technical Data

TURBOVAC

		90 i/iX	250 i/iX	350 i/iX	450 i/iX	T 350 i/iX	T 450 i/iX
High-vacuum connection	DN	63 ISO-K 63 CF	100 ISO-K 100 CF	100 ISO-K 100 CF	160 ISO-K 160 CF	100 ISO-K 100 CF	160 ISO-K 160 CF
Forevacuum connection	DN	16 ISO-KF	16 ISO-KF	25 ISO-KF	25 ISO-KF	25 ISO-KF	25 ISO-KF
Pumping speed							
N ₂	l x s ⁻¹	90	225	290	430	290	430
Ar	l x s ⁻¹	83	210	260	400	260	400
He	l x s ⁻¹	90	250	360	440	360	440
H ₂	l x s ⁻¹	78	210	350	420	320	400
Gas throughput							
N ₂	mbar x l x s ⁻¹	10	6	4.5	4.5	11.5	115
Ar	mbar x l x s ⁻¹	3	3	2	2	6	6
He	mbar x l x s ⁻¹	11	6	8	8	20	20
H ₂	mbar x l x s ⁻¹	11	>10	8	8	20	20
Compression ratio							
N ₂		1 x 10 ¹¹	1 · 10 ¹¹	1 x 10 ¹¹	1 x 10 ¹¹	1 x 10 ¹⁰	1 x 10 ¹⁰
Ar		1 x 10 ¹¹	1 · 10 ¹¹	1 x 10 ¹¹	1 x 10 ¹¹	1 x 10 ¹¹	1 x 10 ¹¹
He		-	-	1 x 10 ⁸	1 x 10 ⁸	1 x 10 ⁶	1 x 10 ⁶
H ₂		5 x 10 ⁷	2 · 10 ⁷	1 x 10 ⁶	1 x 10 ⁶	1 x 10 ⁴	1 x 10 ⁴
Ultimate pressure with 2-stage oil-sealed rotary vane vacuum pump ISO-K / CF flange		mbar (Torr)					
		< 8 x 10 ⁻⁸ / < 5 x 10 ⁻¹⁰ (< 6 x 10 ⁻⁸ / < 3.75 x 10 ⁻¹⁰)					
Max. forevacuum pressure							
N ₂	mbar (Torr)	14 (10.5)	14 (10.5)	10 (7.5)	10 (7.5)	0.5 (0.375)	0.5 (0.375)
Recommended forevacuum pumps							
	TRIVAC	D 2,5 E / D 4 B	D 2,5 E / D 4 B	D 4 B	D 4 B	D 16 B	D 16 B
	SCROLLVAC	SC 5 D	SC 5 D / 15 D	SC 5 D / 15 D	SC 5 D / 15 D	SC 15 D / 30 D	SC 15 D / 30 D
	DIVAC	1.4 HV3	3.8 HV3	3.8 HV3	3.8 HV3	-	-
Operating speed	min ⁻¹ (rpm)	72 000	72 000	60 000	60 000	60 000	60 000
Speed adjustment range	%	62 to 100	62 to 100	50 to 100	50 to 100	50 to 100	50 to 100
Run-up time, approx.	min	1.5	2	5.5	5.5	3.5	3.5
Ambient temperature during operation		°C					
		+5 to +45					
		(°F)					
		(+41 to +113)					
during storage		°C					
		-15 to -70					
		(°F)					
		(+5 to -94)					
Cooling							
standard		Convection					
optional		Air or water					
Cooling water connection alternatively		Plug connection for 6 x 1 hose G 1/8" Screw-in thread					
Cooling water consumption	l/h	30 to 60	30 to 60	50 to 100	50 to 100	50 to 100	50 to 100
Permissible cooling water pressure	bar(g)	3 to 6					
Permissible cooling water temperature	°C	+15 to +35					
	(°F)	(+59 to +95)					
Noise level							
with convection cooling	db(A)	< 41	< 41	< 44	< 44	< 44	< 44
with radial cooler	db(A)	< 44	< 44	< 47	< 47	< 47	< 47
with axial cooler	db(A)	< 49	< 49	< 49	< 49	< 49	< 49

**Additional Technical Data for
the Frequency Converter
(i Version)**

TURBOVAC

		90 i	250 i	350 i	450 i	T 350 i	T 450 i
Technical Data for the integrated Drive Electronics							
Supply voltage	V DC	24/48 ±10%					
Max. current consumption	A	10 at 24 V DC					
Max. power consumption	W	240					
Power consumption at ultimate pressure	W	20					
Type of protection	IP	40					
Interfaces		RS 485, USB, 15-pin digital I/O					
Other interfaces		Upon request					
Accessory connection		1 pcs. M 8 connector, 24 V DC					
Weight ISO-K / CF	kg (lbs)	3.1 / 4.8 (6.8 / 10.6)	4 / 6,6 (8.8 / 14.5)	7.5 / 11.5 (16.5 / 25.4)	7.7 / 12.5 (17.0 / 27.6)	7.0 / 11.0 (15.4 / 14.3)	7.2 / 12.0 (15.9 / 26.5)

**Additional Technical Data for
the Frequency Converter
(iX-Version)**

TURBOVAC

		90 iX	250 iX	350 iX	450 iX	T 350 iX	T 450 iX
Technical Data for the integrated Drive Electronics and Vacuum System Controller							
Supply voltage	V DC	24/48 ±10%					
Max. current consumption	A	10 at 24 V DC					
Max. power consumption	W	240					
Power consumption at ultimate pressure	W	20					
Type of protection	IP	40					
Interfaces		USB+, 15 pin Standard, Anybus (either RS 485, RS 232, Profibus, ...)					
Accessory connections		3 pcs. M 8 connector, 24 V DC					
Max. load for the 24 V DC output (cooler or valve supply)	V / W	24 / max. 12					
Gauge head connection		15-way Sub-D					
Weight ISO-K / CF	kg (lbs)	3.6 / 5.3 (7.9 / 11.7)	4,5 / 7,1 (9.9 / 15.6)	8.0 / 12.0 (17.6 / 26.5)	8.2 / 13.0 (18.1 / 28.7)	7.5 / 11.5 (16.5 / 25.4)	7.7 / 12.5 (17.0 / 27.6)

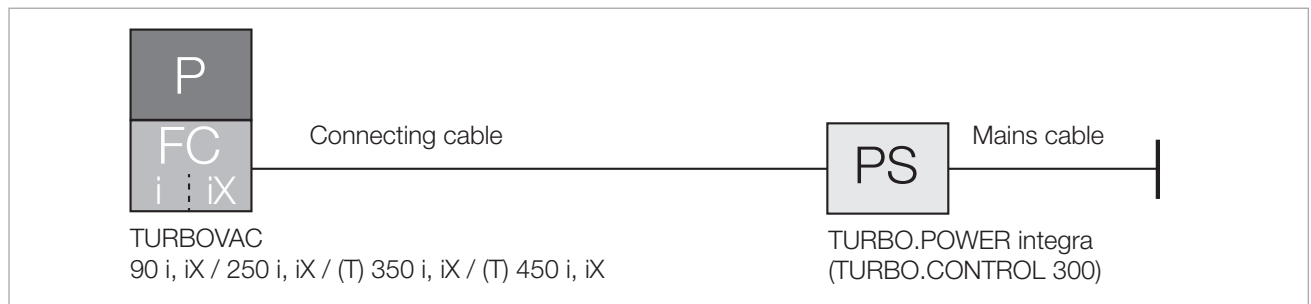

Ordering Information

TURBOVAC

	Wide Range				Classic	
	90 i	250 i	350 i	450 i	T 350 i	T 450 i
	Part No.	Part No.	Part No.	Part No.	Part No.	Part No.
TURBOVAC with integrated frequency converter, RS 485, USB+ and 15-Pin digital I/O interface DN 63 ISO-K	810031V1000	—	—	—	—	—
DN 63 CF	810041V1000	—	—	—	—	—
DN 100 ISO-K	—	820051V1000	830051V1000	—	830050V1000	—
DN 100 CF	—	820061V1000	830061V1000	—	830060V1000	—
DN 160 ISO-K	—	—	—	830071V1000	—	830070V1000
DN 160 CF	—	—	—	830081V1000	—	830080V1000
other interfaces	Upon request					

	Wide Range				Classic	
	90 iX	250 iX	350 iX	450 iX	T 350 iX	T 450 iX
	Part No.	Part No.	Part No.	Part No.	Part No.	Part No.
TURBOVAC with integrated frequency converter, and vacuum system controller, RS 485, USB+ and 15-Pin digital I/O interface DN 63 ISO-K	810031V3300	—	—	—	—	—
DN 63 CF	810041V3300	—	—	—	—	—
DN 100 ISO-K	—	820051V3300	830051V3300	—	830050V3300	—
DN 100 CF	—	820061V3300	830061V3300	—	830060V3300	—
DN 160 ISO-K	—	—	—	830071V3300	—	830070V3300
DN 160 CF	—	—	—	830081V3300	—	830080V3300
other interfaces	Upon request					

Ordering Information

TURBOVAC (T)

90 i, iX / 250 i, iX / 350 i, iX / 450 i, iX

Mandatory Accessories	PIPS	Part No.
Power supply TURBO.POWER integra, including 0.3 (1.1 ft) long cable		800100V0003
Mains cable, 3 m (10.5 ft)		
EU plug		800102V0002
UK plug		800102V0003
US plug 5-15P, 115 V		800102V1002
Cable pump - TURBO.POWER integra		
1 m (3.5 ft)		800096V0100
3 m (10.5 ft)		800096V0300
5 m (17.5 ft)		800096V0500
Mounting kit TURBOVAC		
DN 63 ISO-K		800134V0010
DN 100 ISO-K		800134V0020
DN 160 ISO-K		800134V0030
DN 100 ISO-K to ISO-F		800134V0025
DN 160 ISO-K to ISO-F		800134V0035
DN 63 CF		800134V0011
DN 100 CF		800134V0021
DN 160 CF		800134V0031
Forevacuum pumps TRIVAC D 4 B and TRIVAC D 16 B see Catalog Part "Oil Sealed Vacuum Pumps"		
Forevacuum pumps SCROLLVAC SC 5 D, SCROLLVAC SC 15 D and DIVAC 3.8 HV3 see Catalog Part "Dry Compressing Vacuum Pumps"		
Accessories, optional	P	Part No..
Power supply, cable, other accessories		
Power supply and control unit TURBO.CONTROL 300		800100V0001
Cable pump - TURBO.CONTROL 300		
1 m (3.5 ft)		800092V0100
3 m (10.5 ft)		800092V0300
5 m (17.5 ft)		800092V0500
Extension cable - only in combination with connecting cable 1m (3.5 ft)		
10 m (35 ft)		800092V1000
20 m (70 ft)		800092V2000

Ordering Information

TURBOVAC (T)

90 i, iX / 250 i, iX / 350 i, iX / 450 i, iX

Accessories, optional	P	Part No.
24/48 V DC In plug TURBOVAC		800090V0000
USB-Kabel 2.0, Typ A/B, 1.8 m (6.3 ft) long		800110V0108
Y cable M 8		800110V0020
Relaybox for forevacuum pump, 1-phase, 10 A		800110V0030
Start stop switch		800110V0021
Cooling		
Air cooler		
TURBOVAC 90 i(X)		
radial		800136V0007
axial		800136V0008
TURBOVAC 250 i(X)		
radial		800136V0009
axial		800136V0008
TURBOVAC 350/450 i(X)		
radial		800136V0005
axial		800136V0006
Water cooling TURBOVAC i(X), connection thread G 1/8"		800135V0005
Water cooling TURBOVAC i(X), connection thread G 1/4"		800135V0006
Venting and purge gas		
Venting valve, 24 V DC, G 1/8"		800120V0012
Power failure venting valve, 24 V DC, G 1/8"		800120V0022
Purge gas valve, 24 V DC, G 1/8", 24 sccm		800120V0013
Purge gas throttle, 24 sccm		800120V0014
Air filter, G 1/8"		800110V0022
Heating		
Flange heater (needs mains cable, see above)		
DN 63 CF, 230 V		800137V0003
DN 63 CF, 115 V		800137V0004
DN 100 CF, 230 V		800137V0005
DN 100 CF, 115 V		800137V0006
DN 160 CF, 230 V		800137V0007
DN 160 CF, 115 V		800137V0008
Installation		
Vibration absorber		
DN 100 ISO-K		800131V1100
DN 160 ISO-K		500073
DN 100 CF		500071
DN 160 CF		500072
Centering ring		
with fine inlet screen, 0.8 mm (0.03") mesh		
DN 63 ISO-K/F		800133V0012
DN 100 ISO-K/F		800133V0022
DN 160 ISO-K/F		800133V0032
with coarse inlet screen, 3.2 mm (0.13") mesh		
DN 63 ISO-K/F		800133V0011
DN 100 ISO-K/F		800133V0021
DN 160 ISO-K/F		800133V0031
Fine Inlet screen, 0.8 mm (0.03") mesh		
DN 63 CF		800132V0012
DN 100 CF		800132V0022
DN 160 CF		800132V0032
Coarse inlet screen, 3.2 mm (0.13") mesh		
DN 63 CF		800132V0011
DN 100 CF		800132V0021
DN 160 CF		800132V0031
Included in the Delivery of the Pump		
High and forevacuum flanges are protective-capped		
The flange mounting components and the inlet screen are not included in the delivery		

Special Turbomolecular Pumps



TURBOVAC i Multi Inlet Cartridge

Precision is key when it comes to analytical instruments.

Outfitted with two or more inlets, the innovative turbopumps with integrated drive electronics provide extraordinary pumping performance and are adaptable to the system requirements of each instrument.

In combination with our support for the whole vacuum system design, it will result in the best possible level of pump system integration you have ever experienced.



The TURBOVAC 350-400 i Multi Inlet line has been especially developed to meet the requirements of analytical instruments and features an extremely high level of flexibility, allowing you to choose the number, height and position of the multiple vacuum ports. The result: a pump that is perfectly fitted to your specific performance needs and installation requirements.

Additionally, we offer the support and experience in vacuum system design which opens a wide range of possibilities, from the adaptation of the pump housing to your vacuum chamber through to the design of a custom-built housing/chamber that meets your particular needs. Your benefit: optimum system integration of the pump(s) into your instrument and a reduced time to market.

Your Advantage

- Perfect integration of the pump(s) within your instrumentation
- Cutting of system costs
- Smaller size of the analytical system
- Reduction in the number of individual vacuum components
- Choice between cartridge and custom pump housing

In order to simplify installation, operation and control, all TURBOVAC i variants feature an integrated electronic drive with 24/48 V DC supply and a detachable operator interface with USB, RS 485 and digital I/O connections.

Performance

- Industry-leading pumping speed especially for light gases (up to 60 % higher than existing products)
- Optimized rotor diameter to provide maximum pumping performance
- > 40 l/s pumping speed at Interstage port 2

Flexibility

- Vacuum port design flexibility
 - Rotatable fore-vacuum port
 - Multiple interstage ports
 - High level of flexibility in terms of height and position of vacuum ports
- Unique cartridge solutions for optimized system integration with fast and simple field replacement
- Special pump housing solutions adapted to your instrument
- Complete vacuum system design including your vacuum chamber
- Variable rotor and Holweck design to adapt the performance to your application

Installation, operation and control

- Integrated 24/48 V DC drive electronics to avoid expensive cabling
- Widest range of communication interfaces: USB, RS 485 and remote 15 pin digital I/O as standard options
- Highly efficient motor
- Thermal isolation by design for optimized cooling of bearing and improved pump lifetime
- Simply-supported shaft reduces vibration
- Maintenance free upper passive magnetic bearing
- Oil free, lifetime lubricated lower mechanical ceramic ball bearing, field-replaceable

Outstanding performance

Thanks to its variable rotor and drag stage design, our new Multi Inlet product line provides the highest performance for all mass spectrometer applications. With increased pumping speed levels especially for light gases which are up to 60% higher than those

offered by other products currently on the market, it provides significant advantages for your instruments: lower pressures, improved detection sensitivity levels and higher sample throughput rates.

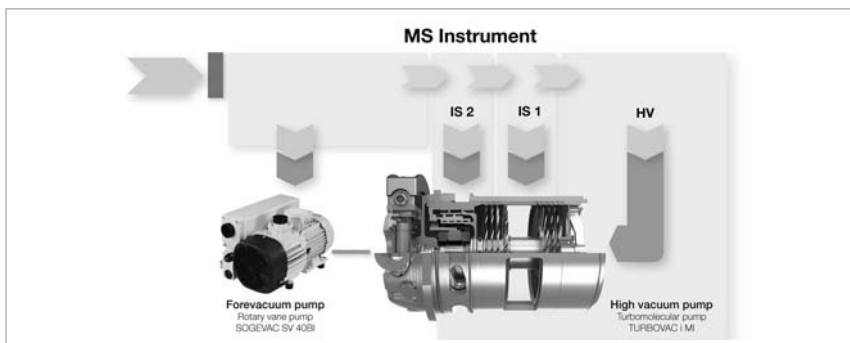
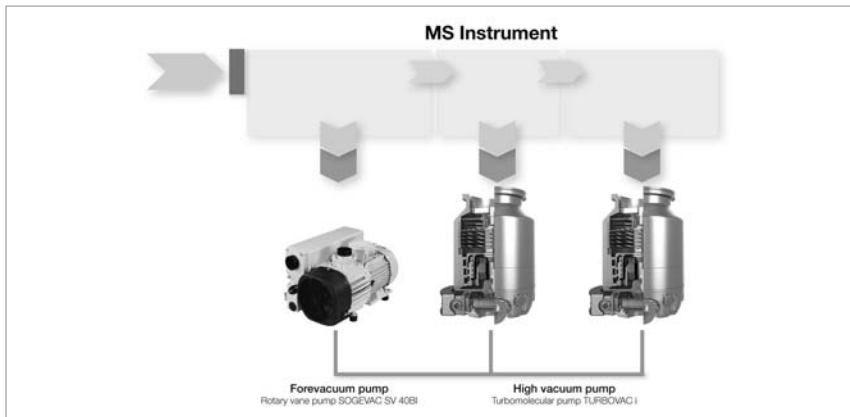

Superior reliability

The unique maintenance and oil free hybrid bearing system is characterized by its extreme reliability and durability – that's because we equipped it with an innovative lifetime lubrication system that never needs an oil change. The simply-supported shaft system results in a low vibration pump design which reduces noise, mechanical stress and negative impact on vibration sensitive applications. Optimized cool-

ing of the bearings is ensured through thermal isolation and the highly efficient motor. To protect the bearings from critical gases or particles, all pumps are equipped with a purge port. As a consequence, not only pump lifetime is increased significantly, but also system uptime as well as productivity. In combination with low costs of ownership, the operation of your vacuum system will be more efficient than ever.

Advantages to the User

- High gas throughput
- High effective pumping speed
- High efficiency for analytical instruments
- High detection sensitivity
- High sample throughput
- Free of hydrocarbons
- Hybrid bearing suspension for low vibration levels
- Space and weight saving
- Low component count
- Favourable price-to-performance ratio
- Installation and user friendly
- Practically maintenance free

Typical Applications

For example

- LC-MS (linking of a liquid chromatograph to a mass spectrometer)
- GC/MS (linking of a gas chromatograph to a mass spectrometer)
- TOF-MS (time-of-flight mass spectrometer)
- ICP-MS (inductively coupled plasma mass spectrometry)
- Helium leak detectors

Technical Features

- Dual Inlet (pumping down of two analysis chambers)
- Triple inlet (pumping down of three analysis chambers)
- High effective pumping speed

HV stage	up to 400 l/s
Interstage IS 1	up to 300 l/s
Interstage IS 2	up to 50 l/s
- Cartridge solutions (without pump housing) are available
- Compact vacuum system

Customized versions are available upon request

Mechanical Rotor Suspension without Compound Stage

TURBOVAC 50



Typical Applications

- Leak detectors
- Mass spectrometers
- Electron beam microscopy
- TV tube manufacturing
- Load locks and transfer chambers
- High vacuum chambers

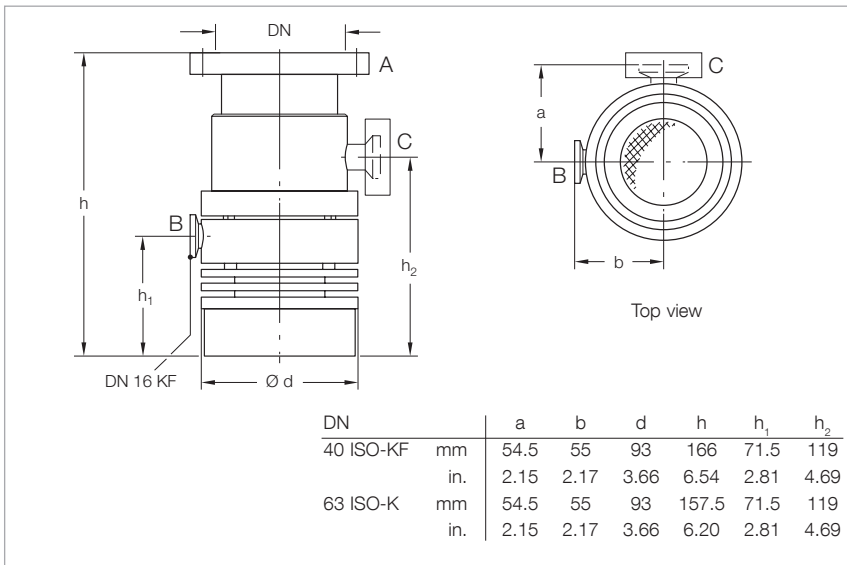

Dimensional drawing for the TURBOVAC 50

Technical Features

- Small footprint
- Installation in any orientation
- Cooling by convection is sufficient for most applications
- Air and water cooling can be added easily
- Oil-free pump for generating clean high and ultra-high vacuum conditions

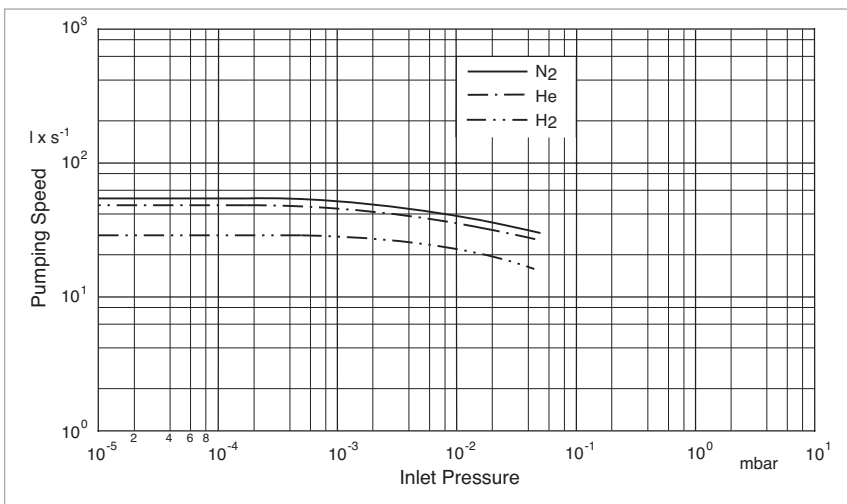

Pumping speed as a function of the inlet pressure (TURBOVAC 50 with flange DN 63 ISO-K)

Advantages to the User

- Space-saving
- Easy to integrate into complex vacuum systems
- Low operating costs
- Highly reliable operation also in processes loaded with particles

Technical Data

TURBOVAC 50

Connection			
Inlet	DN	40 ISO-KF • 40 CF	63 ISO-K • 63 ICF
Outlet	DN	16 ISO-KF	16 ISO-KF
Pumping speed			
N ₂	l x s ⁻¹	33	55
Ar	l x s ⁻¹	30	50
He	l x s ⁻¹	36	48
H ₂	l x s ⁻¹	28	30
Gas throughput			
N ₂	mbar · l x s ⁻¹	0.90	1.00
Ar	mbar · l x s ⁻¹	0.70	0.80
He	mbar · l x s ⁻¹	0.30	0.40
H ₂	mbar · l x s ⁻¹	0.25	0.30
Compression ratio			
N ₂		2 x 10 ⁶	2 x 10 ⁶
Ar		2 x 10 ⁶	2 x 10 ⁶
He		5 x 10 ²	5 x 10 ²
H ₂		2 x 10 ²	2 x 10 ²
Ultimate pressure	mbar (Torr)	< 5 x 10 ⁻⁸ (< 3.8 x 10 ⁻⁸)	< 5 x 10 ⁻⁸ (< 3.8 x 10 ⁻⁸)
Max. foreline pressure for N ₂	mbar (Torr)	1 x 10 ⁻¹ (7.5 x 10 ⁻²)	1 x 10 ⁻¹ (7.5 x 10 ⁻²)
Recommended forevacuum pump		TRIVAC D 2,5 E	TRIVAC D 2,5 E
Nominal rotation speed	min ⁻¹ (rpm)	72 000	72 000
Run-up time, approx.	min	2	2
Max. power consumption	W	45	45
Power consumption at ultimate pressure	W	15	15
Admissible ambient temperature	°C (°F)	+10 to +55 (+50 to +131)	+10 to +55 (+50 to +131)
Cooling			
standard		Convection	Convection
optional		Air / Water	Air / Water
Cooling water connection		10 mm hose nozzle	10 mm hose nozzle
Cooling water consumption	l x h ⁻¹	15 to 25	15 to 25
Permissible cooling water pressure	bar	3 to 7	3 to 7
Permissible cooling water temperature	°C (°F)	+10 to +35 (+50 to +95)	+10 to +35 (+50 to +95)
Weight	kg (lbs)	2.0 (4.4)	2.0 (4.4)



Technical Data

TURBOTRONIK NT 10

Mains connection	50/60 Hz	100-120 or 200-240 V
Max. power consumption	W	45
Max. output voltage	V	3 x 150
Max. output current	A	6
Protection rating	IP	20
Admissible ambient temperature	°C (°F)	0 to +40 (+32 to +104)
Dimensions (W x H x D)	mm (in.)	106 x 128 x 233 (4.17 x 5.04 x 9.17)
Weight, approx.	kg (lbs)	1.5 (3.3)

Ordering Information

TURBOVAC 50

TURBOVAC 50 without Compound Stage	P	Part No.	
DN 40 ISO-KF, convection DN 40 CF, convection DN 63 ISO-K, convection DN 63 CF, convection		854 00 853 99 854 01 854 02	
Mandatory Accessories		FC	PS
Electronic frequency converter TURBOTRONIK NT 10 with EURO plug, 180-240 V with US plug, 90-140 V		859 00 859 01	
Connecting cable converter – TURBOVAC 1.0 m (3.5 ft) 3.0 m (10.5 ft) 5.0 m (17.5 ft) 10.0 m (35.0 ft) 20.0 m (70.0 ft)		200 11 609 121 08 121 09 161 10 800150V2000	
Forevacuum pump TRIVAC D 2,5 E 220-240 V, 50 Hz; 230 V, 60 Hz; Schuko plug, EURO version 110-120 V, 200-240 V, 50/60 Hz; without plug, world version 110-120 V, 50/60 Hz; NEMA plug, US version 100 V, 50/60 Hz; NEMA plug, Japan version		140 000 140 001 140 002 140 003	
For further types, see Catalog Part “Oil sealed Vacuum Pumps”			

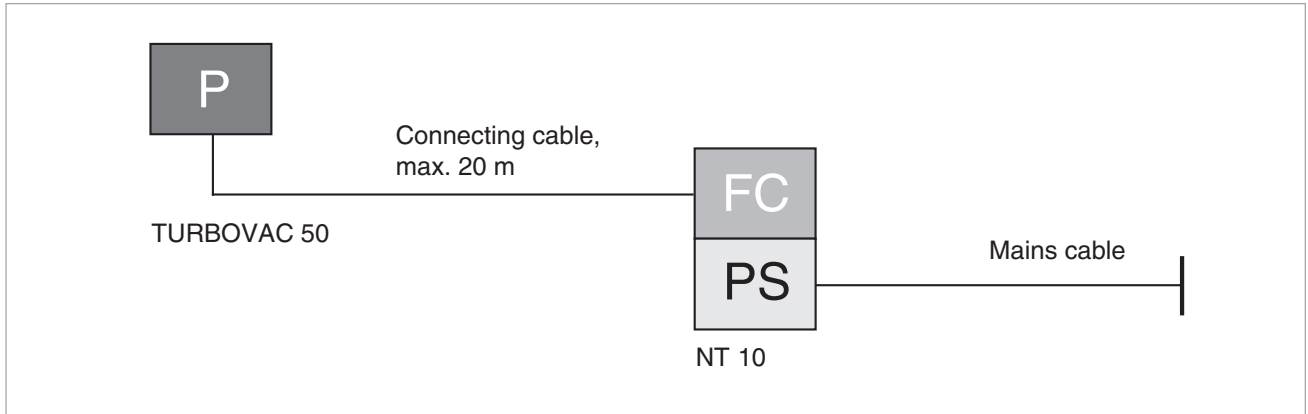

Ordering Information

TURBOVAC 50

Accessories, optional	Part No.
Air cooling unit 230 V AC 100 - 115 V AC	854 05 800152V0015
Water cooling kit (hose nozzles \varnothing 10 mm (0.4 in.))	800135V0003
Vibration absorber DN 63 ISO-K	800131V0063
Solenoid venting valve, normally closed 24 V DC, DN 16 ISO-KF	800120V0011
Power failure venting valve, normally open 24 V DC, DN 16 ISO-KF	800120V0021
Included in the Delivery of the Pump P	
Inlet screen, centering ring with FPM sealing ring, outer ring	ISO-K
Inlet screen, centering ring with FPM O-ring, clamping ring	ISO-KF
Centering ring with O-ring, clamping ring	Foreline Flange
Included in the Delivery of the Frequency Converter FC PS	
Mains cable	

Mechanical Rotor Suspension without Compound Stage

TURBOVAC 151, 151 C ClassicLine



Turbomolecular pumps without a purge gas facility are only suited for pumping of air or inert gases. They are not suited for pumping of aggressive or reactive gases.

TURBOVAC pumps with a "C" in the type designation are equipped with a purge gas facility.

The purge gas protects the bearing area and the motor of the TURBOVAC.

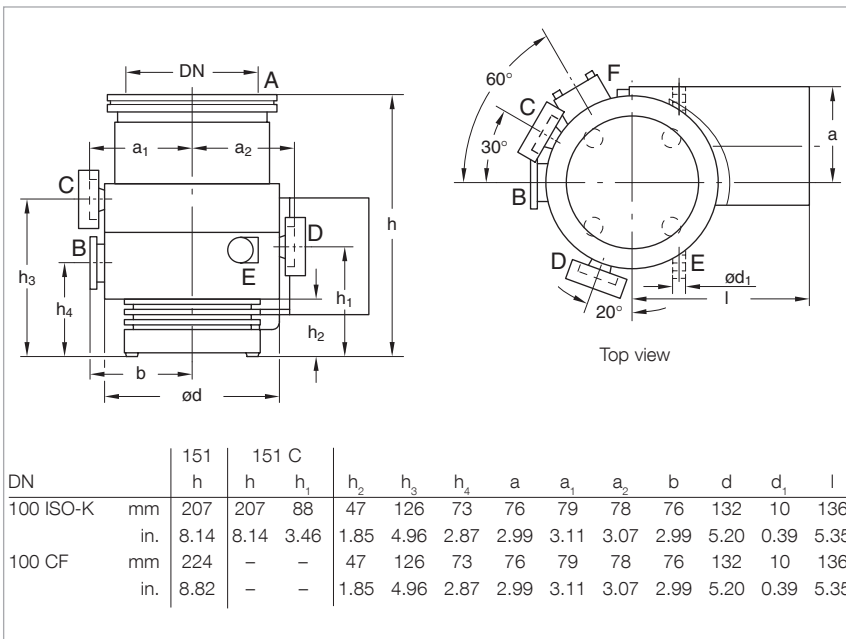

Dimensional drawing for the TURBOVAC 151 and 151 C

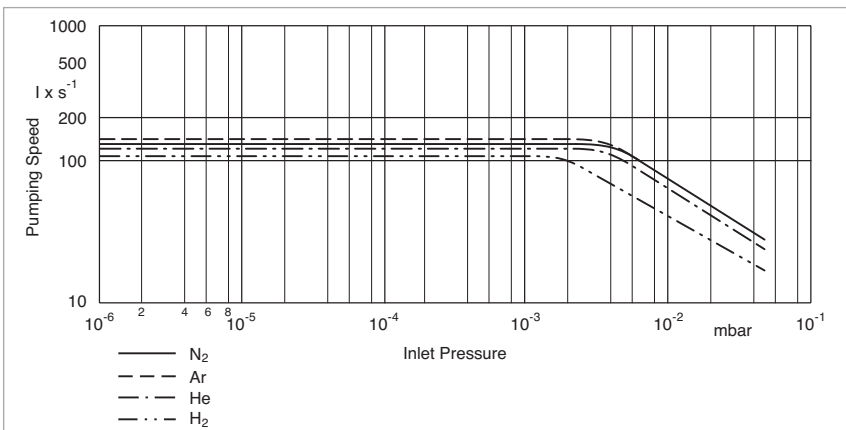

Pumping speed as a function of the inlet pressure (TURBOVAC 151 with flange DN 100)

Typical Applications

- Leak detectors
- Mass spectrometers
- Optical coating
- R & D
- UHV systems
- Particle accelerators
- Load locks and transfer chambers

Technical Features

- Small footprint
- Operation in any orientation
- Oil-free pump for generating clean high and ultra-high vacuum conditions
- Bearing temperature measurement through the TURBO.DRIVE TD 20 *classic*

Advantages to the User

- Space-saving
- Easy to integrate into complex vacuum systems
- Low operating costs
- Highly reliable operation also in processes loaded with particles

Technical Data

TURBOVAC 151 (C)

Connection			
Inlet	DN	100 ISO-K	100 CF
Outlet	DN	25 ISO-KF	25 ISO-KF
Pumping speed			
N ₂	l x s ⁻¹	145	145
Ar	l x s ⁻¹	150	150
He	l x s ⁻¹	135	135
H ₂	l x s ⁻¹	115	115
Gas throughput			
N ₂	mbar · l x s ⁻¹	1.5	1.5
Ar	mbar · l x s ⁻¹	1.3	1.3
He	mbar · l x s ⁻¹	1.5	1.5
H ₂	mbar · l x s ⁻¹	1.0	1.0
Compression ratio			
N ₂		1 x 10 ⁹	1 x 10 ⁹
Ar		1 x 10 ⁹	1 x 10 ⁹
He		2 x 10 ⁴	2 x 10 ⁴
H ₂		8 x 10 ²	8 x 10 ²
Ultimate pressure	mbar (Torr)	< 1 x 10 ⁻¹⁰ (< 7.5 x 10 ⁻¹¹)	< 1 x 10 ⁻¹⁰ (< 7.5 x 10 ⁻¹¹)
Max. foreline pressure for N ₂	mbar (Torr)	5 x 10 ⁻¹ (3.8 x 10 ⁻¹)	5 x 10 ⁻¹ (3.8 x 10 ⁻¹)
Recommended forevacuum pump		from TRIVAC D 4 B to D 16 B	from TRIVAC D 4 B to D 16 B
Nominal rotation speed	min ⁻¹ (rpm)	50 000	50 000
Run-up time, approx.	min	2	2
Max. power consumption	W	300	300
Power consumption at ultimate pressure	W	70	70
Admissible ambient temperature	°C (°F)	10 to 55 (50 to 131)	10 to 55 (50 to 131)
Cooling			
standard		Water	Water
optional		Air	Air
Cooling water connection		10 mm hose nozzle	10 mm hose nozzle
Cooling water consumption	l x h ⁻¹	15 to 35	15 to 35
Permissible cooling water pressure	bar	3 to 7	3 to 7
Permissible cooling water temperature	°C (°F)	10 to 25 (50 to 77)	10 to 25 (50 to 77)
Weight	kg (lbs)	8 (17)	8 (17)



Technical Data

TURBO.DRIVE TD 20 *classic*

Mains connection	50/60 Hz	100 to 240 V (+15 % / -10 %)
Max. power consumption	W	500
Max. output voltage	V	3 x 47
Max. output current	A	5
Interface		Without, RS 232 C, RS 485 C, Profibus or 25-way terminal strip
Protection rating	IP	20
Admissible ambient temperature	°C (°F)	0 to +45 (+32 to +113)
Dimensions (W x H x D)	mm (in.)	213 x 128 x 315 (8.39 x 5.04 x 12.40)
Weight, approx.	kg (lbs)	4.0 (8.8)

Ordering Information

TURBOVAC 151 (C)

TURBOVAC 151 (C) without Compound Stage	P	Part No.	
DN 100 ISO-K, water-cooled DN 100 ISO-K, water-cooled (C version) DN 100 CF, water-cooled DN 100 CF, water-cooled (C version)		856 31 856 35 856 32 103 41	
Mandatory Accessories		FC	PS
TURBO.DRIVE TD 20 ^{classic} without interface with RS 232 C interface with RS 485 C interface with Profibus with 25-pol I/O		800075V0001 800075V0002 800075V0004 800075V0003 800075V0005	
Connecting cable TURBOVAC - frequency converter 3 m (10.5 ft) 5 m (17.5 ft) 10 m (35.0 ft) 20 m (70.0 ft) 50 m (175.0 ft) 60 m (210.0 ft) 80 m (280.0 ft) 140 m (490.0 ft)		857 65 857 66 857 67 857 68 800152V0008 800152V0007 800152V0080 800152V0140	
Mains cable 3 m (10.5 ft) EURO plug UK plug US plug 5-15 P 2 m (7.5 ft) US plug 115 V AC		800102V0002 800102V0003 800102V1002 992 76 513	
Forevacuum pump TRIVAC D 4 B 1 phase motor; 230 V, 50 Hz 1 phase dual voltage motor; 100-120 V / 200-240 V; 50/60 Hz		112 45 140 081 ¹⁾	
TRIVAC D 8 B 1 phase motor; 230 V, 50 Hz 1 phase dual voltage motor; 100-220 V / 200-240 V; 50/60 Hz		112 55 140 082 ¹⁾	
TRIVAC D 16 B 1 phase motor; 230 V, 50 Hz 1 phase motor; 230 V, 50/60 Hz 3 phase motor; 200-240 V/380-400 V, 50 Hz / 200-240 V/380-480 V, 60 Hz		112 65 113 25 112 66	
SCROLLVAC SC 30 D 1 phase motor; 200-230 V, 50/60 Hz 1 phase motor; 100-115 V, 50/60 Hz 3 phase motor; 380-415 V, 50 Hz / 200-230 V, 460 V 60 Hz		133 002 133 102 133 004	
For further types, see Catalog Parts "Oil Sealed Vacuum Pumps" and "Dry Compressing Vacuum Pumps"			

¹⁾ The mains cord (Part No. 200 81 091) must be ordered additionally

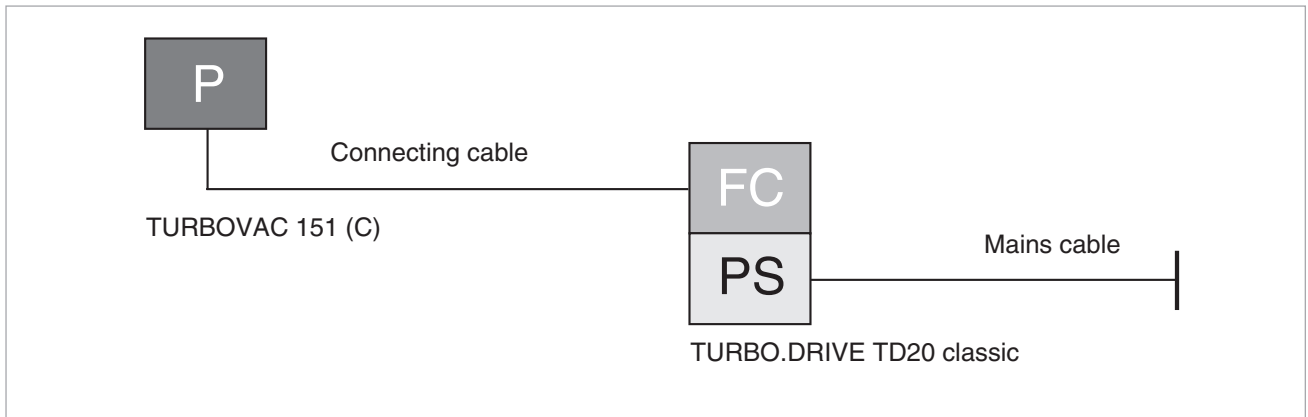

Ordering Information

TURBOVAC 151 (C)

Accessories, optional	Part No.
Air cooling unit 230 V AC 100 - 115 V AC	855 31 800152V0016
Flange heater DN 100 CF, 230 V, 50 Hz DN 100 CF, 115 V, 60 Hz	854 27 854 28
Vibration absorber DN 100 ISO-K DN 100 CF	800131V0100 500 071
Solenoid venting valve, with gas admission filter, normally closed 24 V DC, DN 16 ISO-KF	800120V0011
Power failure venting valve, with gas admission filter, normally open 24 V DC, DN 16 ISO-KF	800120V0021
Purge gas and venting valve gas flow at 1 bar 0.4 mbar x l x s ⁻¹ (24 sccm), pump connection DN 10 ISO-KF / gas connection G 1/4" 230 V AC 100 - 115 V AC 24 V DC	800152V0014 800152V0041 800152V0013
Gas filter to G 1/4" for purge gas and venting valve	800110V0012
Replacement filter (for gas filter to G 1/4" for purge gas and venting valve)	E 200 18 515
Included in the Delivery of the Pump	P
Inlet screen, centering ring with FPM sealing ring, outer ring	ISO-K
Inlet screen	CF
Centering ring with O-ring, clamping ring	Foreline Flange
Pivoted threaded fittings to replace the included hose nipples	Water Cooling

Mechanical Rotor Suspension without Compound Stage

TURBOVAC 361, 361 C ClassicLine



Turbomolecular pumps without a purge gas facility are only suited for pumping of air or inert gases.

They are not suited for pumping of aggressive or reactive gases.

TURBOVAC pumps with a "C" in the type designation are equipped with a purge gas facility.

The purge gas protects the bearing area and the motor of the TURBOVAC.

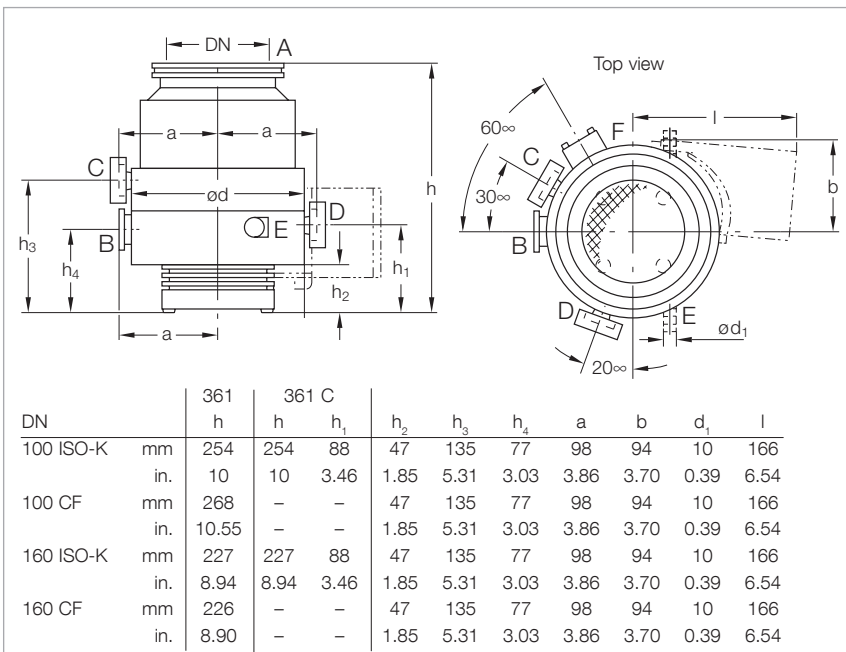

Dimensional drawing for the TURBOVAC 361 and 361 C

Typical Applications

- Leak detectors
- Mass spectrometers
- Data storage
- Optical coating
- R & D
- UHV systems
- Particle accelerators
- Load locks and transfer chambers

Technical Features

- Small footprint
- Installation in any orientation
- Oil-free pump for generating clean high and ultra-high vacuum conditions
- Bearing temperature measurement through the TURBO.DRIVE TD 20 *classic*

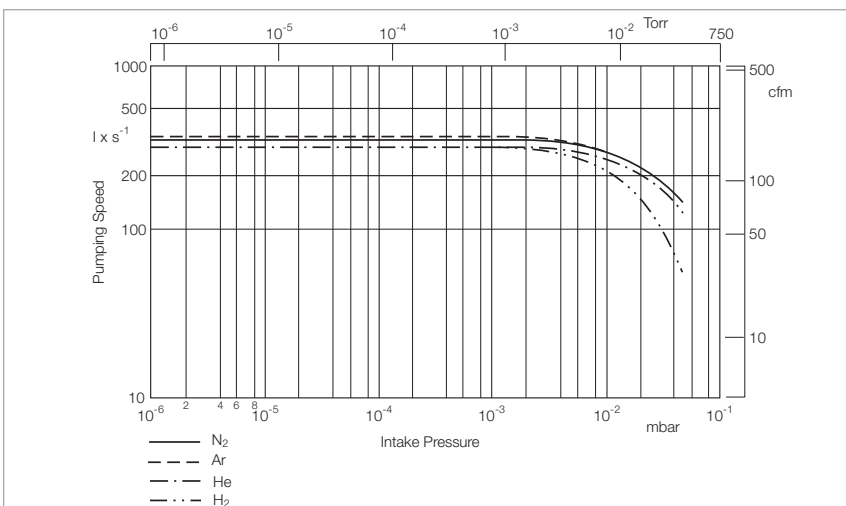

Pumping speed as a function of the inlet pressure (TURBOVAC 361 with flange DN 100)

Advantages to the User

- Space-saving
- Easy to integrate into complex vacuum systems
- Low operating costs
- Highly reliable operation also in processes loaded with particles

Technical Data

TURBOVAC 361 (C)

Connection			
Inlet	DN	100 ISO-K • 100 CF	160 ISO-K • 160 CF
Outlet	DN	25 ISO-KF	25 ISO-KF
Pumping speed			
N ₂	l x s ⁻¹	345	400
Ar	l x s ⁻¹	350	410
He	l x s ⁻¹	340	380
H ₂	l x s ⁻¹	340	370
Gas throughput			
N ₂	mbar · l x s ⁻¹	3.0	3.0
Ar	mbar · l x s ⁻¹	2.5	2.5
He	mbar · l x s ⁻¹	3.0	3.0
H ₂	mbar · l x s ⁻¹	2.0	2.0
Compression ratio			
N ₂		1 x 10 ⁹	1 x 10 ⁹
Ar		1 x 10 ⁹	1 x 10 ⁹
He		6 x 10 ⁴	6 x 10 ⁴
H ₂		3 x 10 ³	3 x 10 ³
Ultimate pressure	mbar (Torr)	< 1 x 10 ⁻¹⁰ (< 7.5 x 10 ⁻¹¹)	< 1 x 10 ⁻¹⁰ (< 7.5 x 10 ⁻¹¹)
Max. foreline pressure for N ₂	mbar (Torr)	5 x 10 ⁻¹ (4 x 10 ⁻¹)	5 x 10 ⁻¹ (3.8 x 10 ⁻¹)
Recommended forevacuum pump		from TRIVAC D 16 B to D 25 B	from TRIVAC D 16 B to D 25 B
Nominal rotation speed	min ⁻¹ (rpm)	45 000	45 000
Run-up time, approx.	min	2	2
Max. power consumption	W	300	300
Power consumption at ultimate pressure	W	70	70
Admissible ambient temperature	°C (°F)	10 to 55 (50 to 131)	10 to 55 (50 to 131)
Cooling			
standard		Water	Water
optional		Air	Air
Cooling water connection		10 mm hose nozzle	10 mm hose nozzle
Cooling water consumption	l x h ⁻¹	15 to 35	15 to 35
Permissible cooling water pressure	bar	3 to 7	3 to 7
Permissible cooling water temperature	°C (°F)	10 to 25 (50 to 77)	10 to 25 (50 to 77)
Weight	kg (lbs)	12 (26)	12 (26)



Technical Data

TURBO.DRIVE TD 20 *classic*

Mains connection	50/60 Hz	100 to 240 V (+15 % / -10 %)
Max. power consumption	W	500
Max. output voltage	V	3 x 47
Max. output current	A	5
Interface		Without, RS 232 C, RS 485 C, Profibus or 25-way terminal strip
Protection rating	IP	20
Admissible ambient temperature	°C (°F)	0 to +45 (+32 to +113)
Dimensions (W x H x D)	mm (in.)	213 x 128 x 315 (8.39 x 5.04 x 12.40)
Weight, approx.	kg (lbs)	4.0 (8.8)

Ordering Information

TURBOVAC 361 (C)

TURBOVAC 361 (C) without Compound Stage	P	Part No.	
DN 100 ISO-K, water-cooled DN 100 ISO-K, water-cooled (C version) DN 100 CF, water-cooled DN 100 CF, water-cooled (C version) DN 160 ISO-K, water-cooled DN 160 ISO-K, water-cooled (C version) DN 160 CF, water-cooled		856 70 856 75 856 71 112 09 856 72 856 77 856 73	
Mandatory Accessories		FC	PS
TURBO.DRIVE TD 20 <small>classic</small> without interface with RS 232 C interface with RS 485 C interface with Profibus with 25-pol I/O		800075V0001 800075V0002 800075V0004 800075V0003 800075V0005	
Connecting cable TURBOVAC - frequency converter 3 m (10.5 ft) 5 m (17.5 ft) 10 m (35.0 ft) 20 m (70.0 ft) 50 m (175.0 ft) 60 m (210.0 ft) 80 m (280.0 ft) 140 m (490.0 ft)		857 65 857 66 857 67 857 68 800152V0008 800152V0007 800152V0080 800152V0140	
Mains cable 3 m (10.5 ft) EURO plug UK plug US plug 5-15 P 2 m (7.5 ft) US plug 115 V AC		800102V0002 800102V0003 800102V1002 992 76 513	
Forevacuum pump TRIVAC D 16 B 1 phase motor; 230 V, 50 Hz 1 phase motor; 230 V, 50/60 Hz 3 phase motor; 200-240 V/380-400 V, 50 Hz / 200-240 V/380-480 V, 60 Hz		112 65 113 25 112 66	
TRIVAC D 25 B 1 phase motor; 230 V, 50 Hz 1 phase motor; 230 V, 50/60 Hz 3 phase motor; 230/400 V, 50 Hz / 250/440 V, 60 Hz		112 75 113 35 112 76	
SCROLLVAC SC 30 D 1 phase motor; 200-230 V, 50/60 Hz 1 phase motor; 100-115 V, 50/60 Hz 3 phase motor; 380-415 V, 50 Hz / 200-230 V, 460 V, 60 Hz		133 002 133 102 133 004	
For further types, see Catalog Parts "Oil Sealed Vacuum Pumps" and "Dry Compressing Vacuum Pumps"			

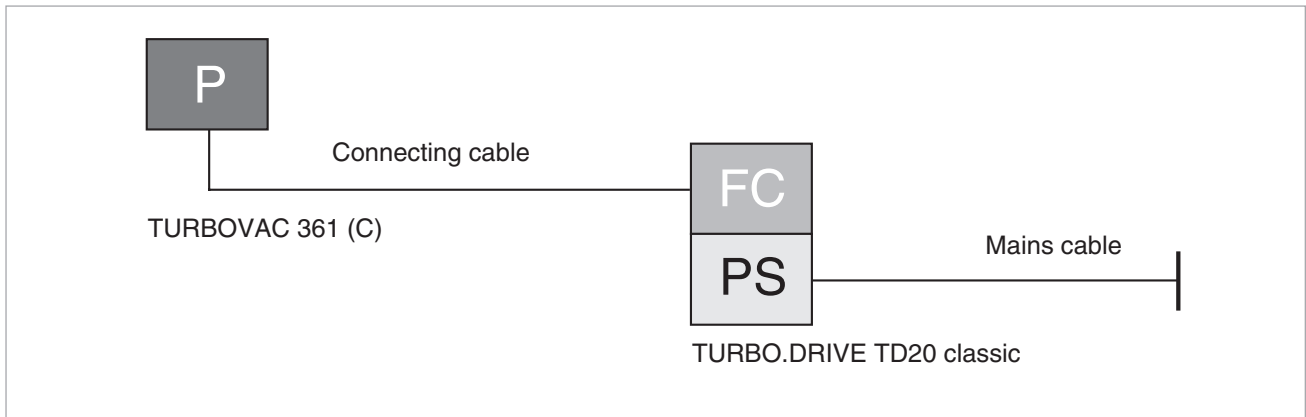

Ordering Information

TURBOVAC 361 (C)

Accessories, optional	Part No.
Air cooling unit 230 V AC 100 - 115 V AC	855 31 800152V0016
Flange heater DN 100 CF, 230 V, 50 Hz DN 100 CF, 115 V, 60 Hz DN 160 CF, 230 V, 50 Hz DN 100 CF, 115 V, 60 Hz	854 27 854 28 854 37 854 38
Vibration absorber DN 100 ISO-K DN 100 CF DN 160 ISO-K DN 160 CF	800131V0100 500 071 500 073 500 072
Solenoid venting valve, with gas admission filter, normally closed 24 V DC, DN 16 ISO-KF	800120V0011
Power failure venting valve, with gas admission filter, normally open 24 V DC, DN 16 ISO-KF	800120V0021
Purge gas and venting valve gas flow at 1 bar 0.4 mbar x l x s ⁻¹ (24 sccm), pump connection DN 10 ISO-KF / gas connection G 1/4" 230 V AC 100 - 115 V AC 24 V DC	800152V0014 800152V0042 800152V0013
Gas filter to G 1/4" for purge gas and venting valve	800110V0012
Replacement filter	E 200 18 515
Included in the Delivery of the Pump	P
Inlet screen, centering ring with FPM sealing ring, outer ring	ISO-K
Inlet screen	CF
Centering ring with O-ring, clamping ring	Foreline Flange
Pivoted threaded fittings to replace the included hose nipples	Water Cooling

Mechanical Rotor Suspension without Compound Stage

TURBOVAC 600 C ClassicLine



Typical Applications

- Load locks and transfer chambers
- Optical coating
- Flat panel displays
- R & D

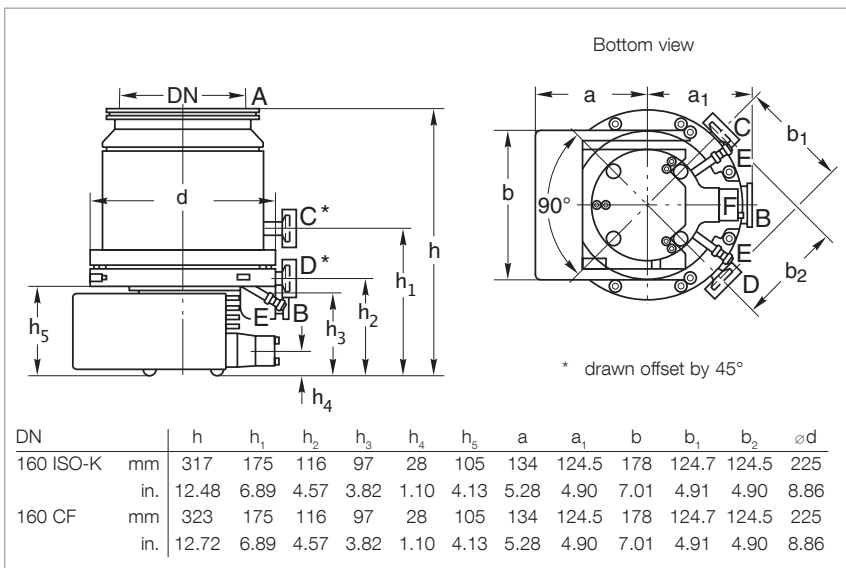

Dimensional drawing for the TURBOVAC 600 C

Technical Features

- Small footprint
- Installation in any orientation
- Oil-free pump for generating clean high and ultra-high vacuum conditions
- Bearing temperature measurement through the TURBO.DRIVE TD 20 *classic*
- Seal gas connection
- Venting connection

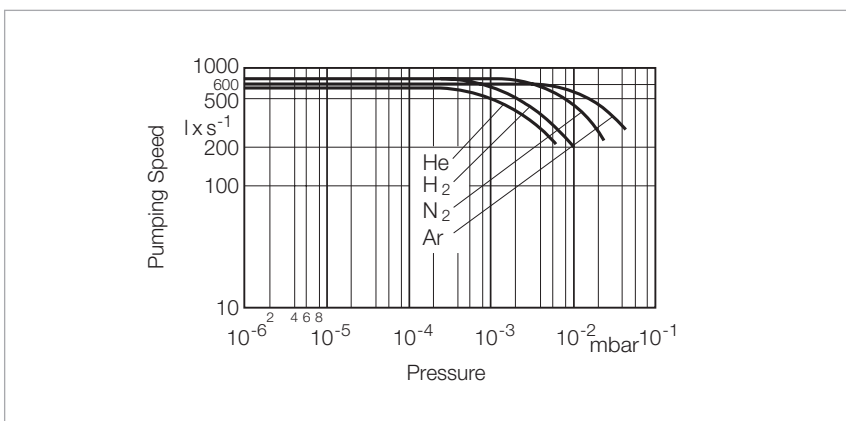

Pumping speed for different gases as a function of intake pressure (TURBOVAC 600 C with flange DN 160 ISO-K)

Advantages to the User

- Installation in any orientation
- Highly reliable due to hybrid ceramic ball bearings

Technical Data

TURBOVAC 600 C

Connection		
Inlet	DN	160 ISO-K • 160 CF
Outlet	DN	40 ISO-KF
Pumping speed		
N ₂	l x s ⁻¹	560
Ar	l x s ⁻¹	550
He	l x s ⁻¹	600
H ₂	l x s ⁻¹	570
Gas throughput		
N ₂	mbar · l x s ⁻¹	4.0
Ar	mbar · l x s ⁻¹	4.0
He	mbar · l x s ⁻¹	5.5
H ₂	mbar · l x s ⁻¹	4.0
Compression ratio		
N ₂		> 10 ⁹
Ar		> 10 ⁹
He		2.0 x 10 ⁴
H ₂		1.1 x 10 ³
Ultimate pressure	mbar (Torr)	< 1.0 x 10 ⁻¹⁰ (< 7.5 x 10 ⁻¹¹)
Max. foreline pressure for N ₂	mbar (Torr)	1.0 x 10 ⁻¹ (7.5 x 10 ⁻²)
Recommended forevacuum pump		TRIVAC D 25 B / D 40 B
Nominal rotation speed	min ⁻¹ (rpm)	36 000
Run-up time, approx.	min	3
Max. power consumption	W	400
Power consumption at ultimate pressure	W	90
Admissible ambient temperature	°C (°F)	10 to 55 (50 to 131)
Cooling		
standard		Water
optional		Air
Cooling water connection		10 mm hose nozzle
Cooling water consumption	l x h ⁻¹	20 to 80
Permissible cooling water pressure	bar	3 to 7
Permissible cooling water temperature	°C (°F)	10 to 30 (50 to 86)
Weight	kg (lbs)	17.0 (37.5)



Technical Data

TURBO.DRIVE TD 20 *classic*

Mains connection	50/60 Hz	100 to 240 V (+15 % / -10 %)
Max. power consumption	W	500
Max. output voltage	V	3 x 47
Max. output current	A	5
Interface		Without, RS 232 C, RS 485 C, Profibus or 25-way terminal strip
Protection rating	IP	20
Admissible ambient temperature	°C (°F)	0 to +45 (+32 to +113)
Dimensions (W x H x D)	mm (in.)	213 x 128 x 315 (8.39 x 5.04 x 12.40)
Weight, approx.	kg (lbs)	4.0 (8.8)

Ordering Information

TURBOVAC 600 C

TURBOVAC 600 C without Compound Stage	P	Part No.	
DN 160 ISO-K, water-cooled DN 160 CF, water-cooled		800150V0015 800150V0017	
<div style="display: inline-block; border: 1px solid black; padding: 2px;">FC</div> <div style="display: inline-block; border: 1px solid black; padding: 2px;">PS</div>			
TURBO.DRIVE TD 20 <small>classic</small> without interface with RS 232 C interface with RS 485 C interface with Profibus with 25-pol I/O		800075V0001 800075V0002 800075V0004 800075V0003 800075V0005	
Connecting cable TURBOVAC - frequency converter 3 m (10.5 ft) 5 m (17.5 ft) 10 m (35.0 ft) 20 m (70.0 ft) 50 m (175.0 ft) 60 m (210.0 ft) 80 m (280.0 ft) 140 m (490.0 ft)		857 65 857 66 857 67 857 68 800152V0008 800152V0007 800152V0080 800152V0140	
Mains cable 3 m (10.5 ft) EURO plug UK plug US plug 5-15 P 2 m (7.5 ft) US plug 115 V AC		800102V0002 800102V0003 800102V1002 992 76 513	
Forevacuum pump TRIVAC D 25 B 1 phase motor; 230 V, 50 Hz 1 phase motor; 230 V, 50/60 Hz 3 phase motor; 230/400 V, 50 Hz / 250/440 V, 60 Hz;		112 75 113 35 112 76	
TRIVAC D 40 B 3 phase motor; 230/400 V, 50 Hz / 250/440 V, 60 Hz 3 phase motor; 200/346 V, 50 Hz / 208/360 V, 60 Hz		112 86 113 47	
SCROLLVAC SC 30 D 1 phase motor; 200-230 V, 50/60 Hz 1 phase motor; 100-115 V, 50/60 Hz 3 phase motor; 380-415 V, 50 Hz / 200-230 V, 460 V, 60 Hz		133 002 133 102 133 004	
For further types, see Catalog Parts "Oil Sealed Vacuum Pumps" and "Dry Compressing Vacuum Pumps"			

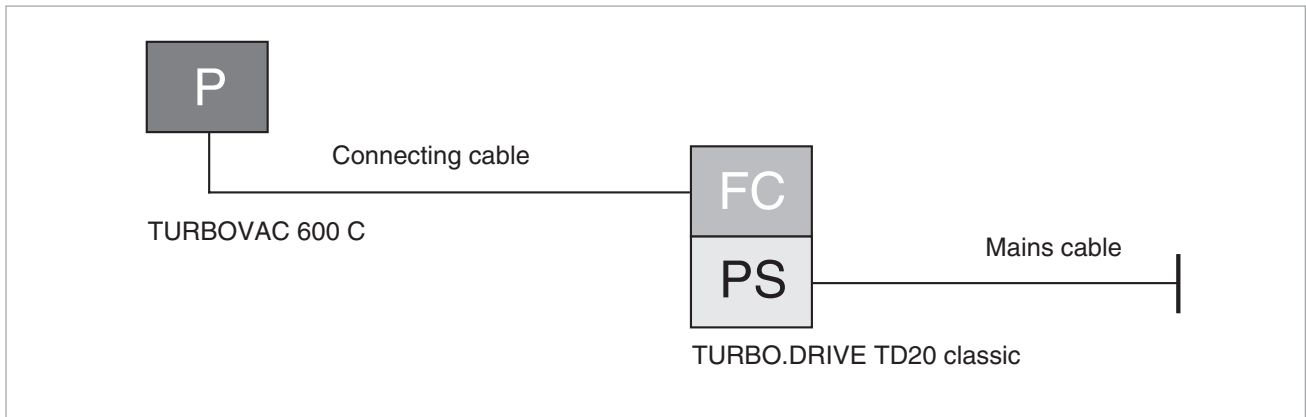

Ordering Information

TURBOVAC 600 C

Accessories, optional	Part No.
Air cooling unit 230 V AC 100 - 115 V AC	855 41 800152V0017
Flange heater DN 160 CF, 230 V, 50 Hz DN 100 CF, 115 V, 60 Hz	854 37 854 38
Vibration absorber DN 160 ISO-K DN 160 CF	500 073 500 072
Solenoid venting valve, with gas admission filter, normally closed 24 V DC, DN 16 ISO-KF	800120V0011
Power failure venting valve, with gas admission filter, normally open 24 V DC, DN 16 ISO-KF	800120V0021
Purge gas and venting valve gas flow at 1 bar 0.6 mbar x l x s ⁻¹ (36 sccm), pump connection DN 10 ISO-KF / gas connection G 1/4" 230 V AC 100 - 115 V AC 24 V DC	800152V0040 800152V0043 800152V0012
Gas filter to G 1/4" for purge gas and venting valve	800110V0012
Replacement filter	E 200 18 515
Included in the Delivery of the Pump	P
Inlet screen, centering ring with FPM sealing ring, outer ring	ISO-K
Inlet screen	CF
Centering ring with O-ring, clamping ring	Foreline Flange
Pivoted threaded fittings to replace the included hose nipples	Water Cooling

Mechanical Rotor Suspension without Compound Stage

TURBOVAC 1000 C ClassicLine



Typical Applications

- Research systems

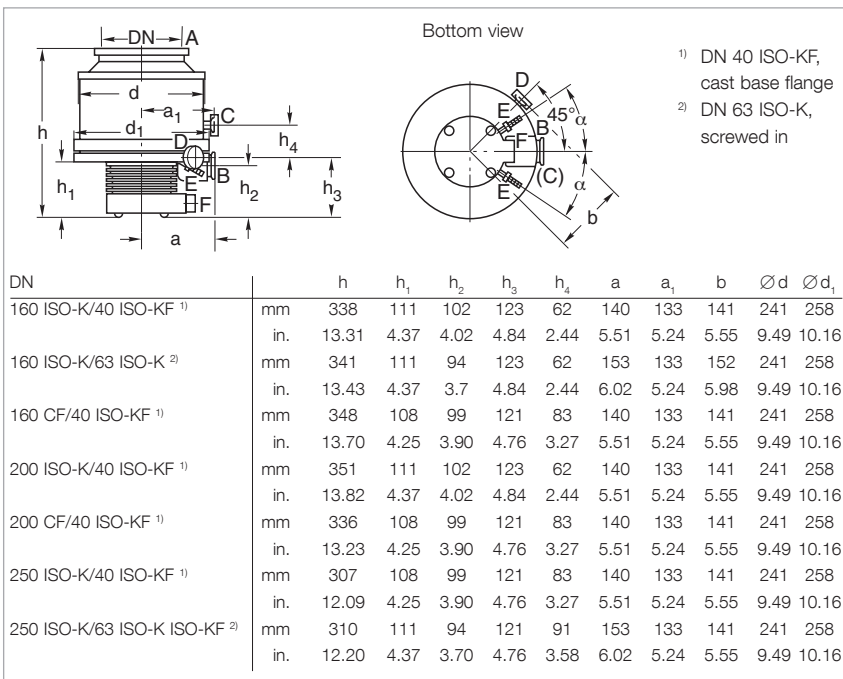

Dimensional drawing for the TURBOVAC 1000 C

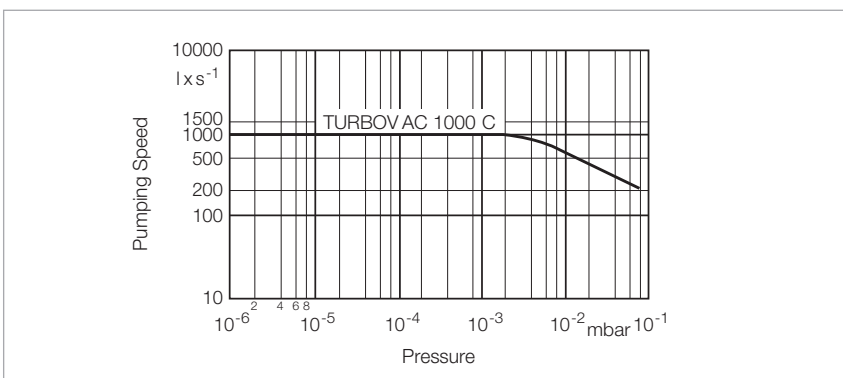

Pumping speed for air as a function of intake pressure (TURBOVAC 1000 C with DN 250 flange)

Technical Features

- Robust rotor design
- Installation in any orientation
- Highest pumping speed and highest throughput
- Bearing temperature measurement through the TURBO.DRIVE TD 20 *classic*
- Seal gas connection
- Venting connection

Advantages to the User

- Installation in any orientation
- Highly reliable due to hybrid ceramic ball bearings
- Standard model: water cooling
- Purge gas facility

Technical Data

TURBOVAC 1000 C

Connection				
Inlet	DN	160 ISO-K • 160 CF	200 ISO-K • 200 CF	250 ISO-K
Outlet	DN	40 ISO-KF • 63 ISO-K	40 ISO-KF	40 ISO-KF • 63 ISO-K
Pumping speed				
N ₂	l x s ⁻¹	850	1100	1150
Ar	l x s ⁻¹	810	1050	1100
He	l x s ⁻¹	880	975	1000
H ₂	l x s ⁻¹	900	970	1000
Gas throughput				
N ₂	mbar · l x s ⁻¹	6.5	6.5	6.5
Ar	mbar · l x s ⁻¹	4.0	4.0	4.0
He	mbar · l x s ⁻¹	7.0	7.0	7.0
H ₂	mbar · l x s ⁻¹	8.0	8.0	8.0
Compression ratio				
N ₂		> 1 x 10 ⁹	> 1 x 10 ⁹	> 1 x 10 ⁹
Ar		> 1 x 10 ⁹	> 1 x 10 ⁹	> 1 x 10 ⁹
He		5 x 10 ⁴	5 x 10 ⁴	5 x 10 ⁴
H ₂		1 x 10 ⁴	1 x 10 ⁴	1 x 10 ⁴
Ultimate pressure	mbar (Torr)	< 1 x 10 ⁻¹⁰ (< 7.5 x 10 ⁻¹¹)	< 1 x 10 ⁻¹⁰ (< 7.5 x 10 ⁻¹¹)	< 1 x 10 ⁻¹⁰ (< 7.5 x 10 ⁻¹¹)
Max. foreline pressure for N ₂	mbar (Torr)	5 x 10 ⁻² (3.8 x 10 ⁻²)	5 x 10 ⁻² (3.8 x 10 ⁻²)	5 x 10 ⁻² (3.8 x 10 ⁻²)
Recommended forevacuum pump for standard operation for purge gas operation		TRIVAC D 25 B / D 40 B TRIVAC D 40 B / D 65 B	TRIVAC D 25 B / D 40 B TRIVAC D 40 B / D 65 B	TRIVAC D 25 B / D 40 B TRIVAC D 40 B / D 65 B
Nominal rotation speed	min ⁻¹ (rpm)	36 000	36 000	36 000
Run-up time, approx.	min	9	9	9
Max. power consumption	W	300	300	300
Power consumption at ultimate pressure	W	200	200	200
Admissible ambient temperature	°C (°F)	10 to 55 (50 to 131)	10 to 55 (50 to 131)	10 to 55 (50 to 131)
Cooling standard optional		Water Air	Water Air	Water Air
Cooling water connection		10 mm hose nozzle	10 mm hose nozzle	10 mm hose nozzle
Cooling water consumption	l x h ⁻¹	20 to 80	20 to 80	20 to 80
Permissible cooling water pressure	bar	3 to 7	3 to 7	3 to 7
Permissible cooling water temperature	°C (°F)	10 to 30 (50 to 86)	10 to 30 (50 to 86)	10 to 30 (50 to 86)
Weight	kg (lbs)	25.0 (55.1)	25.0 (55.1)	25 (55.1)



Technical Data

TURBO.DRIVE TD 20 classic

Mains connection	50/60 Hz	100 to 240 V (+15 % / -10 %)
Max. power consumption	W	500
Max. output voltage	V	3 x 47
Max. output current	A	5
Interface		Without, RS 232 C, RS 485 C, Profibus or 25-way terminal strip
Protection rating	IP	20
Admissible ambient temperature	°C (°F)	0 to +45 (+32 to +113)
Dimensions (W x H x D)	mm (in.)	213 x 128 x 315 (8.39 x 5.04 x 12.40)
Weight, approx.	kg (lbs)	4.0 (8.8)

Ordering Information

TURBOVAC 1000 C

TURBOVAC 1000 C without Compound Stage	P	Part No.		
DN 160 ISO-K / DN 40 ISO-KF, water-cooled DN 160 ISO-K / DN 63 ISO-K, water-cooled DN 160 CF / DN 40 ISO-KF, water-cooled DN 200 ISO-K / DN 40 ISO-KF, water-cooled DN 200 CF / DN 40 ISO-KF, water-cooled DN 250 ISO-K / DN 40 ISO-KF, water-cooled DN 250 ISO-K / DN 63 ISO-K, water-cooled		855 35 855 38 854 91 153 00 117 64 855 36 855 39		
Mandatory Accessories		FC	PS	
TURBO.DRIVE TD 20 <small>classic</small> without interface with RS 232 C interface with RS 485 C interface with Profibus with 25-pol I/O		800075V0001 800075V0002 800075V0004 800075V0003 800075V0005		
Connecting cable TURBOVAC - frequency converter 3 m (10.5 ft) 5 m (17.5 ft) 10 m (35.0 ft) 20 m (70.0 ft) 50 m (175.0 ft) 60 m (210.0 ft) 80 m (280.0 ft) 140 m (490.0 ft)		857 65 857 66 857 67 857 68 800152V0008 800152V0007 800152V0080 800152V0140		
Mains cable 3 m (10.5 ft) EURO plug UK plug US plug 5-15 P 2 m (7.5 ft) US plug 115 V AC		800102V0002 800102V0003 800102V1002 992 76 513		
Forevacuum pump TRIVAC D 25 B 1 phase motor; 230 V, 50 Hz 1 phase motor; 230 V, 50/60 Hz 3 phase motor; 230/400 V, 50 Hz / 250/440 V, 60 Hz		112 75 113 35 112 76		
TRIVAC D 40 B 3 phase motor; 230/400 V, 50 Hz / 250/440 V, 60 Hz 3 phase motor; 200/346 V, 50 Hz / 208/360 V, 60 Hz		112 86 113 47		
TRIVAC D 65 B 3 phase motor; 230/400 V, 50 Hz / 250/440 V, 60 Hz 3 phase motor; 230/346 V, 50 Hz / 208/360 V, 60 Hz		112 96 113 57		
SCROLLVAC SC 30 D 1 phase motor; 200-230 V, 50/60 Hz 1 phase motor; 100-115 V, 50/60 Hz 3 phase motor; 380-415 V, 50 Hz / 200-230 V, 460 V, 60 Hz		133 002 133 102 133 004		
For further types, see Catalog Parts "Oil Sealed Vacuum Pumps" and "Dry Compressing Vacuum Pumps"				

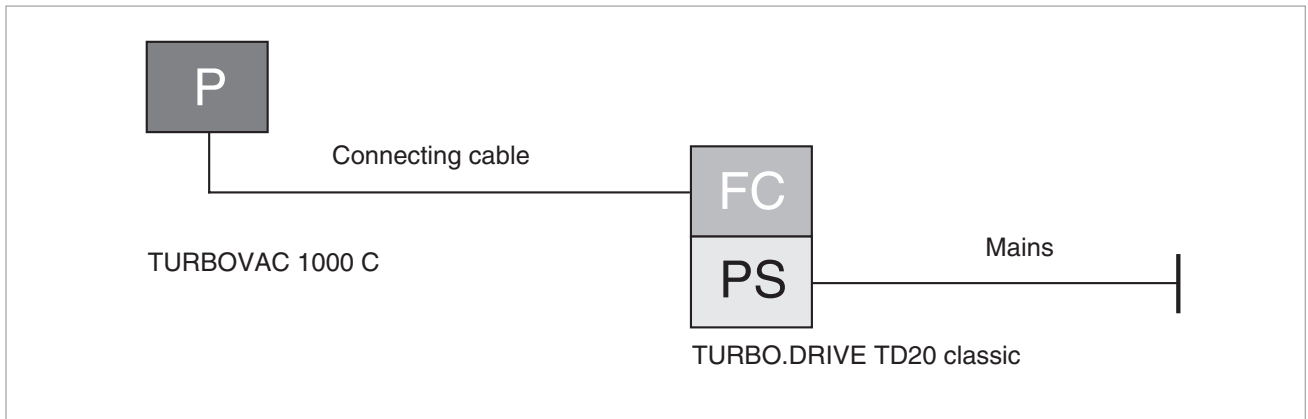

Ordering Information

TURBOVAC 1000 C

Accessories, optional	Part No.
Air cooling unit 230 V AC 100 - 115 V AC	855 41 800152V0017
Flange heater DN 160 CF, 230 V, 50 Hz DN 100 CF, 115 V, 60 Hz	854 37 854 38
Vibration absorber DN 160 ISO-K DN 160 CF	500 073 500 072
Solenoid venting valve, with gas admission filter, normally closed 24 V DC, DN 16 ISO-KF	800120V0011
Power failure venting valve, with gas admission filter, normally open 24 V DC, DN 16 ISO-KF	800120V0021
Purge gas and venting valve gas flow at 1 bar 0.6 mbar x l x s ⁻¹ (36 sccm), pump connection DN 10 ISO-KF / gas connection G 1/4" 230 V AC 100-115 V AC 24 V DC	800152V0040 800152V0043 800152V0012
Gas filter to G 1/4" for purge gas and venting valve	800110V0012
Replacement filter	E 200 18 515
Included in the Delivery of the Pump	P
Inlet screen, centering ring with FPM sealing ring, outer ring	ISO-K
Inlet screen	CF
Centering ring with O-ring, clamping ring	Foreline Flange
Pivoted threaded fittings to replace the included hose nipples	Water Cooling

Mechanical Rotor Suspension without Compound Stage

TURBOVAC 1100 C ClassicLine



Typical Applications

- Data storage
- Flat panel displays
- Optical coating
- Large area coating
- Load locks and transfer chambers

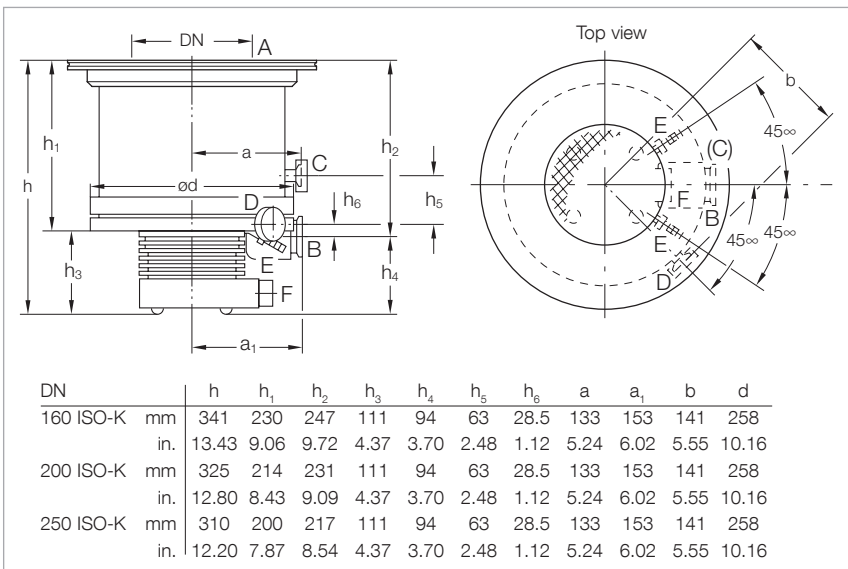

Dimensional drawing for the TURBOVAC 1100 C

Technical Features

- Robust rotor design
- Installation in any orientation
- Highest pumping speed and highest throughput
- Bearing temperature measurement through the TURBO.DRIVE TD 20 *classic*
- Oil-free pump for generating clean high and ultra-high vacuum conditions
- Seal gas connection
- Venting connection

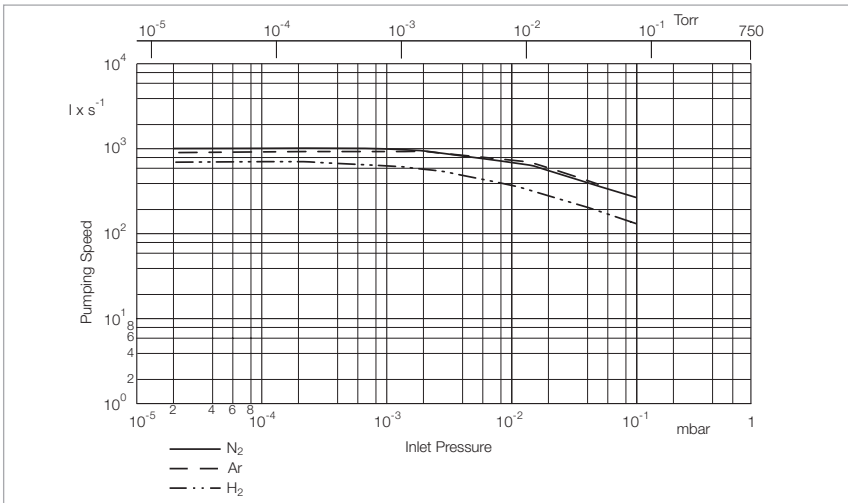

Pumping speed as a function of the inlet pressure (TURBOVAC 1100 C with flange DN 250)

Advantages to the User

- Space-saving
- Easy to integrate into complex vacuum systems
- High productivity
- Low operating costs
- Highly reliable operation also in processes loaded with particles

Technical Data

TURBOVAC 1100 C

Connection				
Inlet	DN	160 ISO-K	200 ISO-K	250 ISO-K
Outlet	DN	63 ISO-K	63 ISO-K	63 ISO-K
Pumping speed				
N ₂	l x s ⁻¹	710	830	1050
Ar	l x s ⁻¹	660	760	980
He	l x s ⁻¹	650	750	850
H ₂	l x s ⁻¹	520	600	630
Gas throughput				
N ₂	mbar · l x s ⁻¹	6.5	6.5	6.5
Ar	mbar · l x s ⁻¹	6.5	6.5	6.5
He	mbar · l x s ⁻¹	8.0	8.0	8.0
H ₂	mbar · l x s ⁻¹	9.0	9.0	9.0
Compression ratio				
N ₂		> 1 x 10 ⁷	> 1 x 10 ⁷	> 1 x 10 ⁷
Ar		> 1 x 10 ⁷	> 1 x 10 ⁷	> 1 x 10 ⁷
He		3 x 10 ⁴	3 x 10 ⁴	3 x 10 ⁴
H ₂		1 x 10 ³	1 x 10 ³	1 x 10 ³
Ultimate pressure	mbar (Torr)	< 3.0 x 10 ⁻¹⁰ (< 2.3 x 10 ⁻¹⁰)	< 3.0 x 10 ⁻¹⁰ (< 2.3 x 10 ⁻¹⁰)	< 3.0 x 10 ⁻¹⁰ (< 2.3 x 10 ⁻¹⁰)
Max. foreline pressure for N ₂	mbar (Torr)	< 1.0 x 10 ⁻¹ (< 7.5 x 10 ⁻²)	< 1.0 x 10 ⁻¹ (< 7.5 x 10 ⁻²)	< 1.0 x 10 ⁻¹ (< 7.5 x 10 ⁻²)
Recommended forevacuum pump		TRIVAC D 65 B / SCROLLVAC SC 15/30 D	TRIVAC D 65 B / SCROLLVAC SC 15/30 D	TRIVAC D 65 B / SCROLLVAC SC 15/30 D
Nominal rotation speed	min ⁻¹ (rpm)	30 000	30 000	30 000
Run-up time, approx.	min	9	9	9
Max. power consumption	W	400	400	400
Power consumption at ultimate pressure	W	300	300	300
Admissible ambient temperature	°C (°F)	10 to 55 (50 to 131)	10 to 55 (50 to 131)	10 to 55 (50 to 131)
Cooling				
standard		Water	Water	Water
optional		Air	Air	Air
Cooling water connection		10 mm hose nozzle	10 mm hose nozzle	10 mm hose nozzle
Cooling water consumption	l x h ⁻¹	24 to 60	24 to 60	24 to 60
Permissible cooling water pressure	bar	3 to 7	3 to 7	3 to 7
Permissible cooling water temperature	°C (°F)	10 to 30 (50 to 86)	10 to 30 (50 to 86)	10 to 30 (50 to 86)
Weight	kg (lbs)	22 (48)	22 (48)	22 (48)

Technical Data

TURBO.DRIVE TD 20 classic

Mains connection	50/60 Hz	100 to 240 V (+15 % / -10 %)
Max. power consumption	W	500
Max. output voltage	V	3 x 47
Max. output current	A	5
Interface		Without, RS 232 C, RS 485 C, Profibus or 25-way terminal strip
Protection rating	IP	20
Admissible ambient temperature	°C (°F)	0 to +45 (+32 to +113)
Dimensions (W x H x D)	mm (in.)	213 x 128 x 315 (8.39 x 5.04 x 12.40)
Weight, approx.	kg (lbs)	4.0 (8.8)

Ordering Information

TURBOVAC 1100 C

TURBOVAC 1100 C without Compound Stage P	Part No.	
DN 160 ISO-K / DN 63 ISO-K, water-cooled DN 200 ISO-K / DN 63 ISO-K, water-cooled DN 250 ISO-K / DN 63 ISO-K, water-cooled	800150V0030 800150V0031 800150V0032	
Mandatory Accessories FC PS		
TURBO.DRIVE TD 20 <small>classic</small> without interface with RS 232 C interface with RS 485 C interface with Profibus with 25-pol I/O	800075V0001 800075V0002 800075V0004 800075V0003 800075V0005	
Connecting cable TURBOVAC - frequency converter 3 m (10.5 ft) 5 m (17.5 ft) 10 m (35.0 ft) 20 m (70.0 ft) 50 m (175.0 ft) 60 m (210.0 ft) 80 m (280.0 ft) 140 m (490.0 ft)	857 65 857 66 857 67 857 68 800152V0008 800152V0007 800152V0080 800152V0140	
Mains cable 3 m (10.5 ft) EURO plug UK plug US plug 5-15 P 2 m (7.5 ft) US plug 115 V AC	800102V0002 800102V0003 800102V1002 992 76 513	
Forevacuum pump TRIVAC D 65 B 3 phase motor; 230/400 V, 50 Hz / 250/440 V, 60 Hz 3 phase motor; 230/346 V, 50 Hz / 208/360 V, 60 Hz	112 96 113 57	
SCROLLVAC SC 30 D 1 phase motor; 200-230 V, 50/60 Hz 1 phase motor; 100-115 V, 50/60 Hz 3 phase motor; 380-415 V, 50 Hz / 200-230 V, 460 V, 60 Hz	133 002 133 102 133 004	
For further types, see Catalog Parts "Oil Sealed Vacuum Pumps" and "Dry Compressing Vacuum Pumps"		

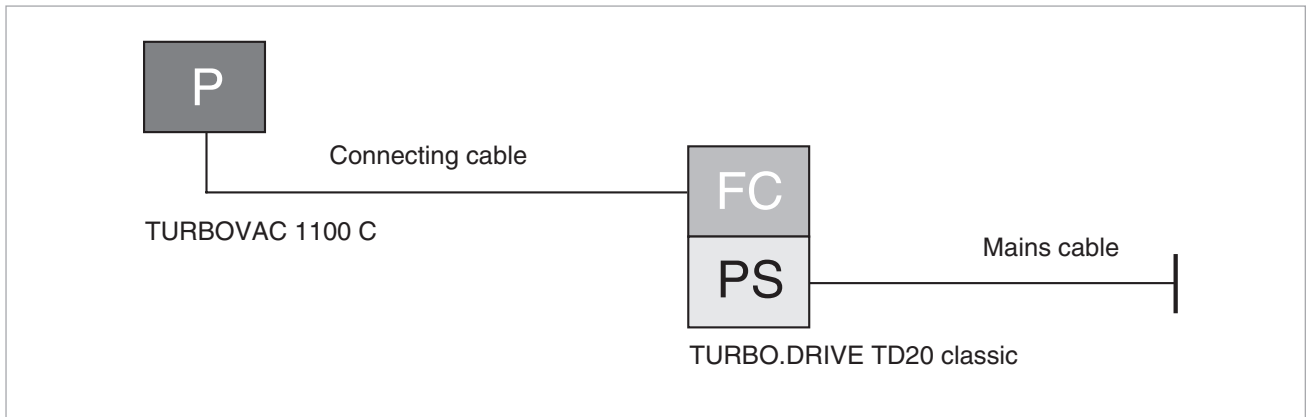

Ordering Information

TURBOVAC 1100 C

Accessories, optional	Part No.
Vibration absorber DN 160 ISO-K	500 073
Solenoid venting valve, with gas admission filter, normally closed 24 V DC, DN 16 ISO-KF	800120V0011
Power failure venting valve, with gas admission filter, normally open 24 V DC, DN 16 ISO-KF	800120V0021
Purge gas and venting valve gas flow at 1 bar 0.6 mbar x l x s ⁻¹ (36 sccm), pump connection DN 10 ISO-KF / gas connection G 1/4" 230 V AC 100-115 V AC 24 V DC	800152V0040 800152V0043 800152V0012
Gas filter to G 1/4" for purge gas and venting valve	800110V0012
Replacement filter	E 200 18 515
Included in the Delivery of the Pump	P
Inlet screen, centering ring with FPM sealing ring, outer ring	ISO-K
Inlet screen	CF
Centering ring with O-ring, clamping ring	Foreline Flange
Pivoted threaded fittings to replace the included hose nipples	Water Cooling

Mechanical Rotor Suspension with Frequency Converter for Attaching or Separate with or without Compound Stage

TURBOVAC SL 80 / L 80 H / SL 80 C



Typical Applications

- Helium leak detectors
- Mass spectrometers (gas chromatography GC-MS), liquid chromatography (LC-MS), residual gas analysis, mobile analytical systems, etc.)
- Electron beam microscopy
- XHV-/UHV systems
- Transfer chambers

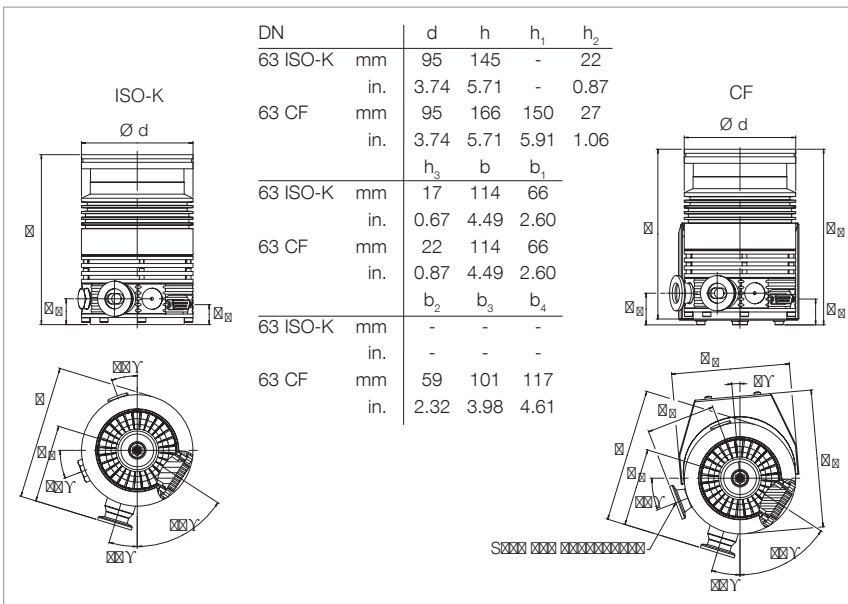

Dimensional drawing for the TURBOVAC SL 80: attachment examples

Technical Features

- Oil-free pump
- High pressure foreline tolerance
- Excellent resistance to vibration due to proven mechanical bearings
- Efficient convection cooling due to a large number of cooling fins
- Purge gas/venting connection
- Installation in any orientation
- Flexible attachment of the frequency converter to the pump
- Small footprint
- Delayed venting through the frequency converter TURBO.DRIVE TD 400 (optional)
- Selection of interfaces, USB, RS 232 C, RS 485 C, Profibus

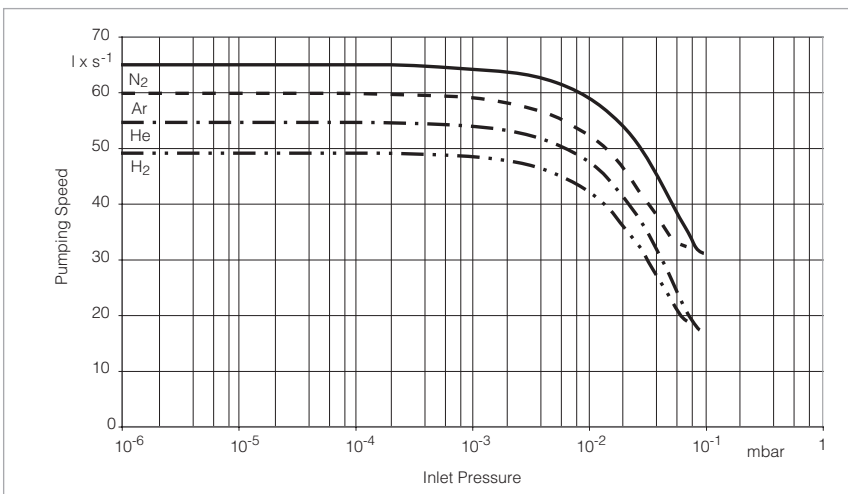

Pumping speed as a function of the inlet pressure

Advantages to the User

- Easy to integrate into complex vacuum systems
- Space-saving
- Prepared for pumping of slightly corrosive gases owing to the seal gas connection
- High reliability, MTTF over 200,000 hours
- Matching accessories (fan, water cooling, seal gas/venting valves, power failure venting valves, flange heaters, different cable lengths etc.)
- High reliability due to self-monitoring

Technical Data

TURBOVAC

SL 80

SL 80 H

SL 80 C

Connection		SL 80			SL 80 H		SL 80 C	
Inlet	DN	40 ISO-KF	63 ISO-K	63 CF	63 ISO-K	63 CF	63 ISO-K	
Outlet	DN	16 ISO-KF			16 ISO-KF		16 ISO-KF	
Pumping speed								
N ₂	l x s ⁻¹	40	65	65	65		70	
Ar	l x s ⁻¹	34	60	60	60		65	
He	l x s ⁻¹	44	55	55	55		50	
H ₂	l x s ⁻¹	40	49	49	49		45	
Gas throughput								
N ₂	mbar · l x s ⁻¹	2.0			0.9		3.5	
Ar	mbar · l x s ⁻¹	1.6			0.8		3.5	
He	mbar · l x s ⁻¹	1.2			1.5		2.0	
H ₂	mbar · l x s ⁻¹	0.5			0.6		1.0	
Compression ratio								
N ₂		> 1 x 10 ¹¹			> 1 x 10 ¹¹		2 x 10 ⁶	
Ar		> 1 x 10 ¹¹			> 1 x 10 ¹¹		2 x 10 ⁶	
He		2 x 10 ⁶			6 x 10 ⁶		6 x 10 ²	
H ₂		4 x 10 ⁴			8 x 10 ⁴		2 x 10 ²	
Ultimate pressure								
	mbar Torr)	< 2 x 10 ⁻¹⁰ (< 1.5 x 10 ⁻¹⁰)			< 2 x 10 ⁻¹⁰ (< 1.5 x 10 ⁻¹⁰)		< 5 x 10 ⁻⁸ (< 4.0 x 10 ⁻⁸)	
Max. foreline pressure for N ₂		16 (12)			16 (12)		0.35 (0.26)	
Recommended forevacuum pump		TRIVAC D 2,5 E / D 4 B SCROLLVAC SC 5 D / 15 D DIVAC 1.4 HV3			TRIVAC D 2,5 E / D 4 B SCROLLVAC SC 5 D / 15 D DIVAC 1.4 HV3		TRIVAC D 2,5 E / D 4 B SCROLLVAC SC 5 D / 15 D -	
Nominal rotation speed		72 000			72 000		72 000	
Run-up time, approx.		1.5			1.5		1.5	
Max. power consumption		120			120		120	
Power consumption at ultimate pressure		17			17		17	
Admissible ambient temperature		+15 to +45 (+50 to +113)			+15 to +45 (+50 to +113)		+15 to +45 (+50 to +113)	
Cooling								
standard		Convection			Convection		Convection	
optional		Water / Air			Water / Air		Water / Air	
Cooling water connection		G 1/8", inside thread / 8 mm hose nozzle			G 1/8", inside thread / 8 mm hose nozzle		G 1/8", inside thread / 8 mm hose nozzle	
Cooling water consumption		15 to 60			15 to 60		15 to 60	
Permissible cooling water pressure		2 to 7			2 to 7		2 to 7	
Permissible cooling water temperature		10 to 40 (50 to 104)			10 to 40 (50 to 104)		10 to 40 (50 to 104)	
Weight, approx.		1.8 1.9 3.1 (3.97) (4.19) (6.84)			1.9 3.1 (4.19) (6.84)		1.9 (4.19)	





Technical Data

TURBO.DRIVE TD 400

Mains connection	V DC	24
Max. current consumption	A	8
Max. power consumption	W	190
Max. output voltage	V	3 x 24
Interface		USB, RS 232 C, RS 485 C or Profibus
Protection rating	IP	20
Admissible ambient temperature	°C (°F)	+5 to +45 (+41 to +113)
Dimensions (W x H x D)	mm (in.)	100 x 90 x 100 (3.9 x 3.5 x 3.9)
Weight, approx.	kg (lbs)	0.7 (1.6)

Ordering Information

TURBOVAC SL 80 / SL 80 H / SL 80 C

TURBOVAC SL 80	P	Part No.			
with compound stage DN 40 ISO-KF DN 63 ISO-K / DN 16 ISO-KF DN 63 ISO-K / DN 16 ISO-KF (SL 80 H) DN 63 CF / DN 16 ISO-KF DN 63 CF / DN 16 ISO-KF (SL 80 H)		800002V3004 800002V3001 800002V3005 800002V3002 800002V3006			
without compound stage DN 63 ISO-K / DN 16 ISO-KF (SL 80 C)		800002V3008			
Mandatory Accessories	P	FC	PS		
Electronic frequency converter TURBO.DRIVE TD 400 with USB interface with RS 232 C interface with RS 485 C interface with Profibus				800073V0008 800073V0002 800073V0003 800073V0004	
Connecting cable pump - frequency converter 0.2 m (0.7 ft) 0.3 m (1.1 ft) 0.4 m (1.4 ft) 0.5 m (1.75 ft) 1.0 m (3.5 ft) 2.5 m (8.75 ft) 3.0 m (10.5 ft) 5.0 m (17.5 ft) 10.0 m (35.0 ft)				800152V0021 800152V0023 800152V0022 800152V0050 152 47 864 49 864 40 864 50 800080V1000	
Power supply and control unit TURBO.CONTROL 300				800100V0001	
24 V connecting cable power supply - TURBO.CONTROL 300 1 m (3.5 ft) 3 m (10.5 ft) 5 m (17.5 ft) 10 m (35.0 ft) 20 m (70.0 ft)				800091V0100 800091V0300 800091V0500 800091V1000 800091V2000	
Power supply TURBO.POWER 300				800100V0002	
24 V connecting cable power supply - TURBO.POWER 300 1 m (3.5 ft) 3 m (10.5 ft) 5 m (17.5 ft) 10 m (35.0 ft) 20 m (70.0 ft)				800094V0100 800094V0300 800094V0500 800094V1000 800094V2000	
Mains cable 3 m (10.5 ft) - TURBO.CONTROL 300 / TURBO.POWER 300 with EURO plug with UK plug with US plug 5-15 P with US plug 115 V AC, 2 m (7.5 ft)				800102V0002 800102V0003 800102V1002 992 76 513	
START/STOP switch for manual operation of the turbomolecular pump				152 48	
Forevacuum pump TRIVAC D 2,5 E 220-240 V, 50 Hz; 230 V, 60 Hz; Schuko plug, EURO version 110-120 V / 220-240 V, 50/60 Hz, without plug, (world version)				140 000 140 001	
TRIVAC D 4 B 1 phase EURO motor; 230 V, 50 Hz 1 phase dual voltage motor; 100-120 V / 200-240 V; 50/60 Hz				112 45 140 081 ¹⁾	
DIVAC 1.4 HV3 90-230 V, 50/60 Hz				127 90 V	
SCROLLVAC SC 5 D 1 phase motor; 200-230 V, 50/60 Hz 1 phase motor; 100-115 V, 50/60 Hz				133 000 133 100	
SCROLLVAC SC 15 D 1 phase motor; 200-230 V, 50/60 Hz 1 phase motor; 100-115 V, 50/60 Hz 3 phase motor; 380-415 V, 50 Hz / 200-230 V, 460 V, 60 Hz				133 001 133 101 133 003	
For further types, see Catalog Parts "Oil Sealed Vacuum Pumps" and "Dry Compressing Vacuum Pumps"					

¹⁾ The mains cord (Part No. 200 81 091) must be ordered additionally

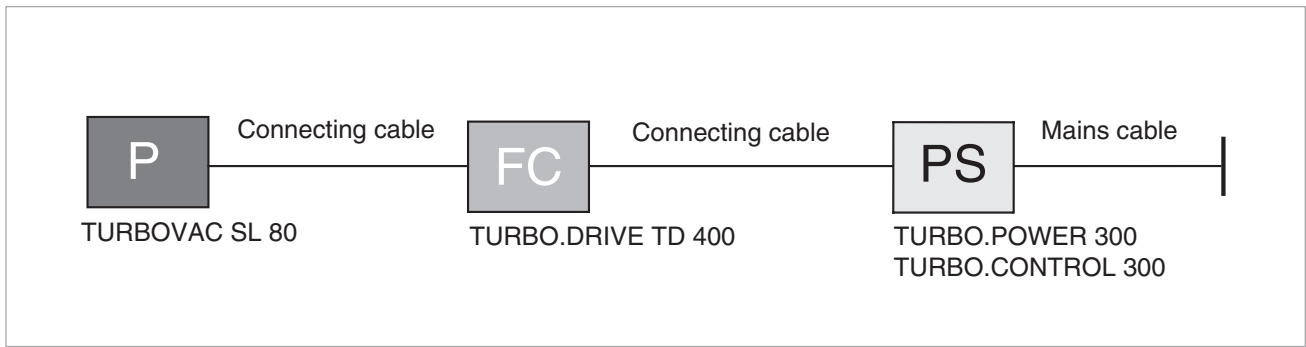

Ordering Information

TURBOVAC SL 80 / SL 80 H / SL 80 C

Accessories, optional	P	FC	PS	Part No.
Mounting kit TD 400 for SL 80, incl. 0.2 m (0.7 ft.) long connecting cable pump - frequency converter for installing the frequency converter beside the pump for installing the frequency converter beneath the pump (not for 800073V0007)				800110V0005 800110V0008
Water cooling unit with 2x G 1/8" connections, including 2 hose nozzles G 1/8" 8 mm (0.3 in.) OD, 2 gaskets (copper) 10 x 14 x 1 mm (0.4 x 0.6 x 0.04 in.) and hose clamps				800135V0001
Air cooling unit				800136V0001
Flange heater DN 63 CF, 230 V, 50 Hz DN 63 CF, 115 V, 60 Hz				854 04 854 07
Inlet screen DN 40 ISO-KF DN 63 ISO-K (coarse) DN 63 CF (coarse)				E 200 17 169 E 200 17 170 E 200 17 171
Fine filter with centering ring DN 63 ISO-K				887 20
Vibration absorber DN 63 ISO-K DN 63 CF				800131V0063 500 070
Pump connection adapter DN 10 ISO-KF / pump connection M 8 (incl. O-ring, filter and clamping ring)				800110V0011
Purge gas and venting valve gas flow at 1 bar 0.4 mbar x l x s ⁻¹ (24 sccm), pump connection DN 10 ISO-KF / gas connection G 1/4" 230 V AC 100 - 115 V AC 24 V DC				800152V0014 800152V0042 800152V0013
Gas filter to G 1/4" for purge gas and venting valve				800110V0012
Replacement filter				E 200 18 515
Power failure venting valve, normally open 24 V DC, DN 16 ISO-KF				800120V0021
Power failure venting valve, normally open 24 V DC, DN 10 ISO-KF 230 V AC / 50/60 Hz, DN 10 ISO-KF				174 46 174 26
Hat rail adaptor as mounting aid				800110V0003
Fin type cooler				800110V0001

MAG INTEGRA - Magnetic Rotor Suspension with integrated Frequency Converter, with Compound Stage

TURBOVAC MAG W 300/400 iP



Typical Applications

- Gas analysis systems
- Particle accelerators
- Electron microscopes
- Research
- Coating systems

Technical Features

- Installation in any orientation
- DN 100 or 160 ISO-K and/or CF high vacuum connection
- DN 16 ISO-KF with clamped fore vacuum connection
- Purge gas/venting connection DN 16 ISO-KF with clamped connection (purge/vent)
- Water or air cooling optional
- 2 slots for industrial communications modules
- Standard 9 pin 24 V SPS PLC-IO in Control Slot
- RS 232 C in Service Slot
- further interfaces can be fitted: Profibus, RS 485 C, DeviceNet, EtherNet IP, EtherCat

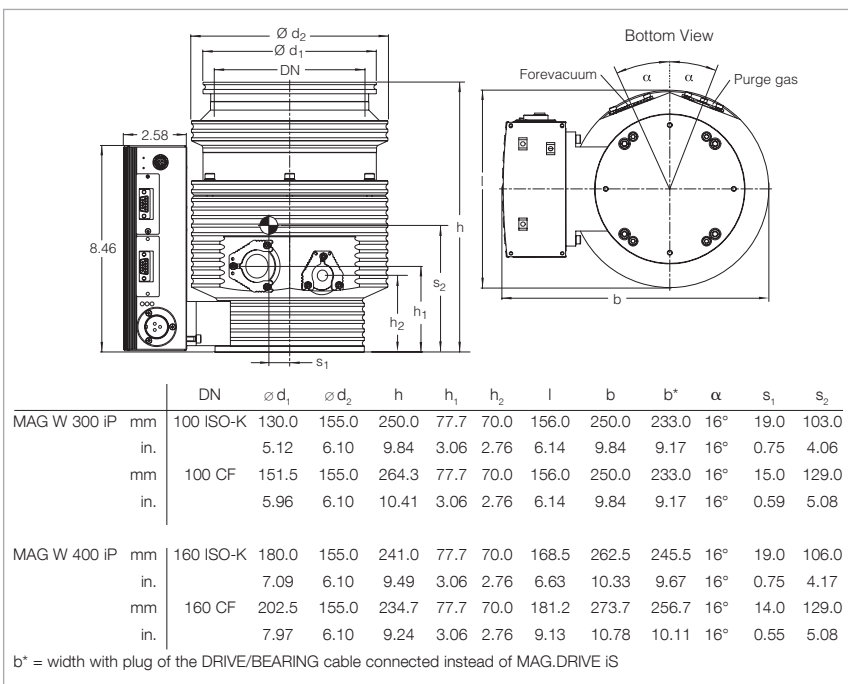

Dimensional drawing for the TURBOVAC MAG W 300/400 iP

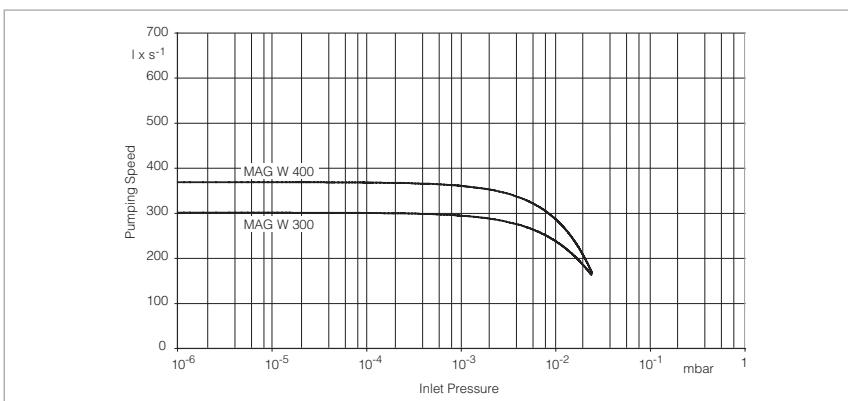

Pumping speed for N_2 of the TURBOVAC MAG W 300/400 iP as a function of the inlet pressure

Advantages to the User

- Highest pumping speed from the smallest possible size
- New standard regarding maintenance-free systems
- Suitability for vibration sensitive applications in the area of analytical engineering, thin-film technology, electron microscopes, research, development among others
- Flexibility due to the modular concept; the converter is optionally also available by way of a bench top unit

Technical Data

TURBOVAC MAG

W 300 iP

W 400 iP

Inlet flange	DN	100 ISO-K	100 CF	160 ISO-K	160 CF
Pumping speed					
N ₂	l x s ⁻¹	300	300	365	365
Ar	l x s ⁻¹	260	260	330	330
He	l x s ⁻¹	260	260	280	280
H ₂	l x s ⁻¹	190	190	200	200
Operating speed	min ⁻¹	58 800	58 800	58 800	58 800
Compression ratio					
N ₂		1.0 x 10 ¹⁰	1.0 x 10 ¹⁰	1.0 x 10 ¹⁰	1.0 x 10 ¹⁰
H ₂		3.2 x 10 ³	3.2 x 10 ³	3.2 x 10 ³	3.2 x 10 ³
He		9.2 x 10 ⁴	9.2 x 10 ⁴	9.2 x 10 ⁴	9.2 x 10 ⁴
Ultimate pressure	mbar (Torr)	< 10 ⁻⁸ (< 0.75 x 10 ⁻⁹)	< 10 ⁻¹⁰ (< 0.75 x 10 ⁻¹⁰)	< 10 ⁻⁸ (< 0.75 x 10 ⁻⁹)	< 10 ⁻¹⁰ (< 0.75 x 10 ⁻¹⁰)
Max. degassing temperature	°C (°F)	–	80 (176)	–	80 (176)
Max. foreline pressure for N ₂	mbar (Torr)	8 (6)	8 (6)	8 (6)	8 (6)
Recommended backing pump		TRIVAC D 2,5 E TRIVAC D 8 B	TRIVAC D 2,5 E TRIVAC D 8 B	TRIVAC D 2,5 E TRIVAC D 8 B	TRIVAC D 2,5 E TRIVAC D 8 B
Run-up time	min	< 5	< 5	< 5	< 5
Foreline flange (clamped)	DN	16 ISO-KF	16 ISO-KF	16 ISO-KF	16 ISO-KF
Purge / vent port (clamped)	DN	16 ISO-KF	16 ISO-KF	16 ISO-KF	16 ISO-KF
Water cooling connection (optional)	G	1/8"	1/8"	1/8"	1/8"
Weight, approx.	kg (lbs)	12 (26)	12 (26)	12 (26)	12 (26)

Technical Data



Integrated Frequency Converter

TURBO.DRIVE iS

Power supply	V	48	48	48	48
Ripple	%	< 2	< 2	< 2	< 2
Power consumption					
maximum	W	400	400	400	400
at ultimate pressure	W	259	259	259	259
DC current consumption, max.	A	7.5 to 9.3	7.5 to 9.3	7.5 to 9.3	7.5 to 9.3
DC power supply voltage range	V	43 to 53	43 to 53	43 to 53	43 to 53
Length of the DC connection cable, max.					
at 3 x 1.5 mm ²	m (ft)	5 (17.5)	5 (17.5)	5 (17.5)	5 (17.5)
at 3 x 2.5 mm ²	m (ft)	20 (70.0)	20 (70.0)	20 (70.0)	20 (70.0)
Contact rating for the relays, max.		32 V; 0,5 A	32 V; 0,5 A	32 V; 0,5 A	32 V; 0,5 A
Permissible ambient temperature					
during operation	°C (°F)	+10 to +40 (+50 to +104)	+10 to +40 (+50 to +104)	+10 to +40 (+50 to +104)	+10 to +40 (+50 to +104)
during storage	°C (°F)	0 to +60 (0 to +140)	0 to +60 (0 to +140)	0 to +60 (0 to +140)	0 to +60 (0 to +140)
Relative humidity of the air, non-condensing	%	5 to 85	5 to 85	5 to 85	5 to 85
Protection class	IP	30	30	30	30
Overvoltage category		II	II	II	II
Pollution category		2	2	2	2

Ordering Information

TURBOVAC MAG W 300/400 iP

TURBOVAC MAG W 300 iP with Integrated Frequency Converter and Seal Gas Connection	Part No.	
DN 100 ISO-K DN 100 CF	410300V0505 410300V0506	
TURBOVAC MAG W 400 iP with Integrated Frequency Converter and Seal Gas Connection		
DN 160 ISO-K DN 160 CF	410400V0505 410400V0506	
Mandatory Accessories		
Power supply TURBO.POWER 501	410300V5221	
DC cable frequency converter - power supply 1 m (3.5 ft) 3 m (10.5 ft) 5 m (17.5 ft) 10 m (35.0 ft) 20 m (70.0 ft)	410300V2001 410300V2003 410300V2005 410300V2010 410300V2020	
Mains cable, 3 m (10.5 ft) with EURO plug with US plug 5-15 P	800102V0002 800102V1002	
Forevacuum pump TRIVAC D 2,5 E 220-240 V, 50 Hz; 230 V, 60 Hz; Schuko plug, EURO version 110-120 V, 50/60 Hz; NEMA plug, US version	140 000 140 002	
TRIVAC D 8 B 1 phase motor; 230 V, 50/60 Hz 3 phase motor; 230/400 V, 50 Hz; 250/440 V, 60 Hz	112 55 112 56	

With integrated Frequency Converter

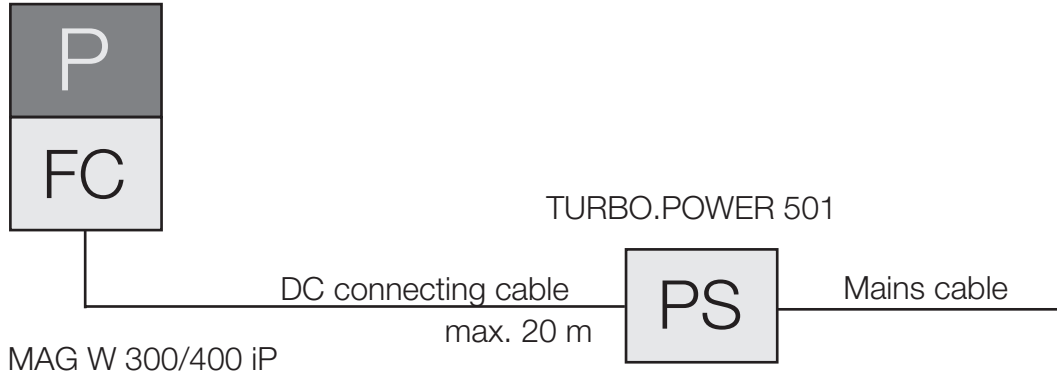

Ordering Information

TURBOVAC MAG W 300/400 iP

Accessories, optional	P	Part No.
Inlet screen		
DN 100 ISO-K		
coarse (3.2 x 3.2 mm (0.13 x 0.13 in.))		800132V0101
fine (1.6 x 1.6 mm (0.06 x 0.06 in.))		800132V0102
DN 100 CF		
coarse (3.2 x 3.2 mm (0.13 x 0.13 in.))		200 91 514
fine (1.6 x 1.6 mm (0.06 x 0.06 in.))		E 200 17 195
DN 160 ISO-K		E 200 00 307
DN 160 CF		E 200 17 247
Flange heater		
100 CF, 230 V, 50 Hz		854 27
100 CF, 115 V, 60 Hz		854 28
160 CF, 230 V, 50 Hz		854 37
160 CF, 115 V, 60 Hz		854 38
Water cooling unit		410300V0101
Air cooling unit		410300V0102
START/STOP switch for manual operation of the turbomolecular pump		152 48
DC plug		800 001 694
Solenoid venting valve, normally closed		
24 V DC, DN 16 ISO-KF		800120V0011
Power failure venting valve, normally open		800120V0021
Included in the Delivery of the Pump	P	
Flanges for forevacuum, venting and purge gas are blank-flanged		
Centering ring with FPM sealing ring and a clamping yoke		

MAG INTEGRA - Magnetic Rotor Suspension with integrated Frequency Converter, with Compound Stage

TURBOVAC MAG W 600/700 iP



Typical Applications

- Gas analysis systems
- Particle accelerators
- Electron microscopes
- Research
- Coating systems

Technical Features

- Installation in any orientation
- DN 160 or 200 ISO-K and/or CF high vacuum connection
- DN 25 ISO-KF with clamped forevacuum connection
- Purge gas/venting connection DN 16 ISO-KF with clamped connection (purge/vent)
- Water or air cooling optional
- 2 slots for industrial communications modules
- Standard 9 pin 24 V SPS PLC-IO in Control Slot
- RS 232 C in Service Slot
- further interfaces can be fitted: Profibus, RS 485 C, DeviceNet, EtherNet IP, EtherCat

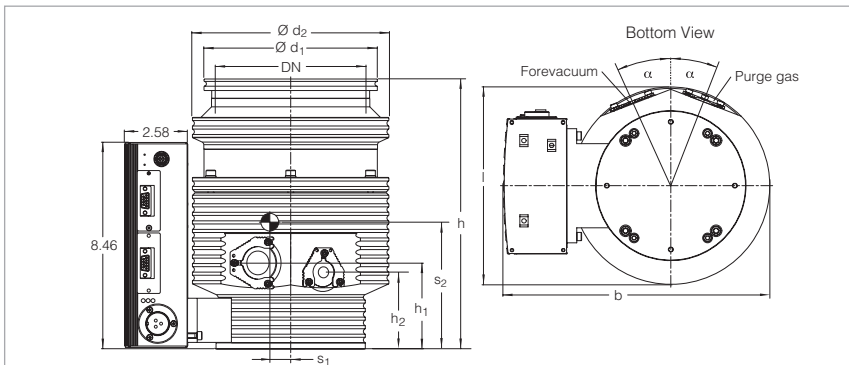

	DN	$\varnothing d_1$	$\varnothing d_2$	h	h_1	h_2	l	b	b^*	α	s_1	s_2
MAG W 600 iP	mm 160 ISO-K	180.0	204.0	281.5	90	80	204.0	274.5	257.5	21°	13.0	121.0
	in. 160 CF	7.09	8.03	11.08	3.54	3.15	8.03	10.81	10.14	21°	0.51	4.76
MAG W 700 iP	mm 200 ISO-K	240.0	204.0	280.5	90	80	240.0	292.5	275.5	21°	13.0	130.0
	in. 200 CF	9.45	8.03	11.04	3.54	3.15	9.45	11.52	10.85	21°	0.51	5.12
	mm 200 CF	253.0	204.0	275.0	90	80	253.0	299.0	282.0	21°	9.0	156.0
	in.	9.96	8.03	10.83	3.54	3.15	9.96	11.77	11.10	21°	0.35	6.14

b^* = width with plug of the DRIVE/BEARING cable connected instead of MAG.DRIVE IS

Dimensional drawing for the TURBOVAC MAG W 600/700 iP

Advantages to the User

- Highest pumping speed from the smallest possible size
- New standard regarding maintenance-free systems
- Suitability for vibration sensitive applications in the area of analytical engineering, thin-film technology, electron microscopes, research, development among others
- Flexibility due to the modular concept; the converter is optionally also available by way of a bench top unit

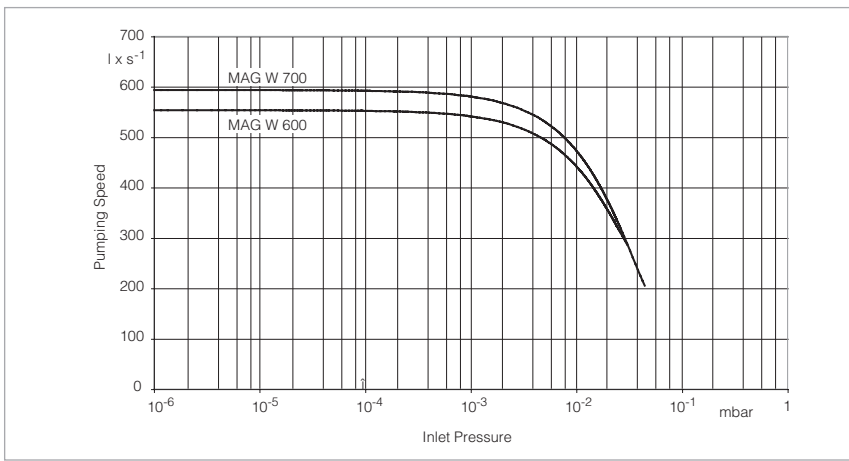

Pumping speed for N₂ of the TURBOVAC MAG W 600/700 iP as a function of the inlet pressure

Technical Data

TURBOVAC MAG

W 600 iP

W 700 iP

Inlet flange	DN	160 ISO-K	160 CF	200 ISO-K	200 CF
Pumping speed					
N ₂	l x s ⁻¹	550	550	590	590
Ar	l x s ⁻¹	520	520	540	540
He	l x s ⁻¹	570	570	600	600
H ₂	l x s ⁻¹	410	410	430	430
Operating speed	min ⁻¹	48 000	48 000	48 000	48 000
Compression ratio					
N ₂		1.6 x 10 ¹⁰	1.6 x 10 ¹⁰	1.6 x 10 ¹⁰	1.6 x 10 ¹⁰
H ₂		3.4 x 10 ⁴	3.4 x 10 ⁴	3.4 x 10 ⁴	3.4 x 10 ⁴
He		1.7 x 10 ⁶	1.7 x 10 ⁶	1.7 x 10 ⁶	1.7 x 10 ⁶
Ultimate pressure	mbar (Torr)	< 10 ⁻⁸ (< 0.75 x 10 ⁻⁸)	< 10 ⁻¹⁰ (< 0.75 x 10 ⁻¹⁰)	< 10 ⁻⁸ (< 0.75 x 10 ⁻⁸)	< 10 ⁻¹⁰ (< 0.75 x 10 ⁻¹⁰)
Max. degassing temperature	°C (°F)	–	80 (176)	–	80 (176)
Max. foreline pressure for N ₂	mbar (Torr)	6.0 (4.5)	6.0 (4.5)	6.0 (4.5)	6.0 (4.5)
Recommended backing pump		TRIVAC D 2,5 E TRIVAC D 8 B	TRIVAC D 2,5 E TRIVAC D 8 B	TRIVAC D 2,5 E TRIVAC D 8 B	TRIVAC D 2,5 E TRIVAC D 8 B
Run-up time	min	< 6	< 6	< 6	< 6
Foreline flange (clamped)	DN	25 ISO-KF	25 ISO-KF	25 ISO-KF	25 ISO-KF
Purge / vent port (clamped)	DN	16 ISO-KF	16 ISO-KF	16 ISO-KF	16 ISO-KF
Water cooling connection (optional)	G	1/8"	1/8"	1/8"	1/8"
Weight, approx.	kg (lbs)	17 (37.5)	17 (37.5)	17 (37.5)	17 (37.5)

Technical Data



Integrated Frequency Converter

TURBO.DRIVE iS

Power supply	V	48	48	48	48
Ripple	%	< 2	< 2	< 2	< 2
Power consumption					
maximum	W	400	400	400	400
at ultimate pressure	W	259	259	259	259
DC current consumption, max.	A	7.5 to 9.3	7.5 to 9.3	7.5 to 9.3	7.5 to 9.3
DC power supply voltage range	V	43 to 53	43 to 53	43 to 53	43 to 53
Length of the DC connection cable, max.					
at 3 x 1.5 mm ²	m (ft)	5 (17.5)	5 (17.5)	5 (17.5)	5 (17.5)
at 3 x 2.5 mm ²	m (ft)	20 (70.0)	20 (70.0)	20 (70.0)	20 (70.0)
Contact rating for the relays, max.		32 V; 0,5 A	32 V; 0,5 A	32 V; 0,5 A	32 V; 0,5 A
Permissible ambient temperature					
during operation	°C (°F)	+10 to +40 (+50 to +104)	+10 to +40 (+50 to +104)	+10 to +40 (+50 to +104)	+10 to +40 (+50 to +104)
during storage	°C (°F)	0 to +60 (0 to +140)	0 to +60 (0 to +140)	0 to +60 (0 to +140)	0 to +60 (0 to +140)
Relative humidity of the air, non-condensing	%	5 to 85	5 to 85	5 to 85	5 to 85
Protection class	IP	30	30	30	30
Overvoltage category		II	II	II	II
Pollution category		2	2	2	2

Ordering Information

TURBOVAC MAG W 600/700 iP

TURBOVAC MAG W 600 iP with Integrated Frequency Converter and Seal Gas Connection	PFC	Part No.	
DN 160 ISO-K DN 160 CF		410600V0505 410600V0506	
TURBOVAC MAG W 700 iP with Integrated Frequency Converter and Seal Gas Connection	PFC		
DN 200 ISO-K DN 200 CF		410700V0505 410700V0506	
Mandatory Accessories		PFC	
Power supply TURBO.POWER 501		410300V5221	
DC cable frequency converter - power supply 1 m (3.5 ft) 3 m (10.5 ft) 5 m (17.5 ft) 10 m (35.0 ft) 20 m (70.0 ft)		410300V2001 410300V2003 410300V2005 410300V2010 410300V2020	
Mains cable, 3 m (10.5 ft) with EURO plug with US plug 5-15 P		800102V0002 800102V1002	
Forevacuum pump TRIVAC D 2,5 E 220-240 V, 50 Hz; 230 V, 60 Hz; Schuko plug, EURO version 110-120 V, 50/60 Hz; NEMA plug, US version		140 000 140 002	
TRIVAC D 8 B 1 phase motor; 230 V, 50/60 Hz 3 phase motor; 230/400 V, 50 Hz; 250/440 V, 60 Hz		112 55 112 56	

With integrated Frequency Converter

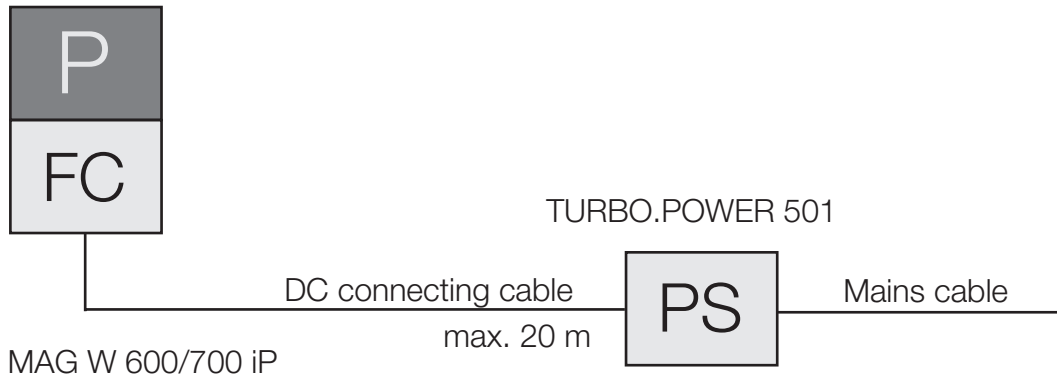

Ordering Information

TURBOVAC MAG W 600/700 iP

Accessories, optional	P	Part No.
Inlet screen		
DN 160 ISO-K		E 200 00 307
DN 160 CF		E 200 17 247
DN 200 ISO-K		200 91 639
DN 200 CF		400 001 515
Flange heater		
160 CF, 230 V, 50 Hz		854 37
160 CF, 115 V, 60 Hz		854 38
Water cooling unit		410600V0101
Air cooling unit		410600V0102
START/STOP switch for manual operation of the turbomolecular pump		152 48
DC plug		800 001 694
Solenoid venting valve, normally closed 24 V DC, DN 16 ISO-KF		800120V0011
Power failure venting valve, normally open		800120V0021
Included in the Delivery of the Pump	P	
Flanges for forevacuum, venting and purge gas are blank-flanged		
Centering ring with FPM sealing ring and a clamping yoke		

MAG INTEGRA - Magnetic Rotor Suspension with integrated Frequency Converter, with and without Compound Stage

TURBOVAC MAG W 1300 iP(L) to 2201 iP(L)



Typical Applications

- PVD coatings systems
- Coating of architectural glass
- Optical coatings
- LC displays
- Flat panels
- Research
- Analytical systems

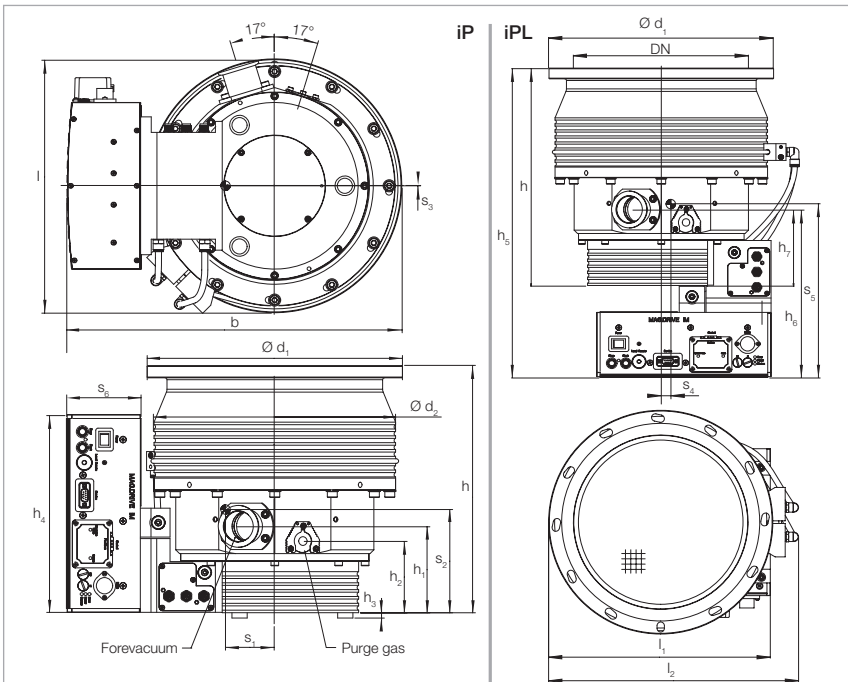

Technical Features

- Installation in any orientation
- DN 200 and/or 250 in ISO-F and/or CF high vacuum connection
- DN 40 KF forevacuum connection
- Purge gas/venting connection DN 16 KF with clamped connection (purge/vent)
- Water cooling
- Protection class IP 54
- RS 232 C in Service Slot
- 1 slot for industrial communications modules
- Standard ProfiBus
- further interfaces can be fitted: RS 485 C, 9 pin 24 V PLC, DeviceNet, EtherNet IP, EtherCat

Type	DN		b	d ₁	d ₂	h	h ₁	h ₂	h ₃	h ₄	h ₅	h ₆
MAG W 1300	200 ISO-F	mm	420 ¹⁾	285	285	305	114	94	7	260	442	251
		in.	16.54 ¹⁾	11.22	11.22	12.01	4.49	3.70	0.38	10.24	17.40	9.88
	200 CF	mm	416	254	285	335	114	94	7	260	472	251
		in.	16.38	10.00	11.22	13.19	4.49	3.70	0.38	10.24	18.58	9.88
MAG W 1600/1601/1700	250 ISO-F	mm	442	335	317	325	114	94	7	260	463	251
		in.	17.40	13.19	12.48	12.80	4.49	3.70	0.38	10.24	18.23	9.88
	250 CF	mm	432	305	317	330	114	94	7	260	467	251
		in.	17.01	12.01	12.48	12.99	4.49	3.70	0.38	10.24	18.39	9.88
MAG W 2200/2201	250 ISO-F	mm	450	335	349	355	114	94	7	260	492	251
		in.	17.18	13.19	13.74	13.19	4.49	3.70	0.38	10.24	19.37	9.88
	250 CF	mm	446	305	349	372	114	94	7	260	506	251
		in.	17.56	12.01	13.74	14.65	4.49	3.70	0.38	10.24	19.92	9.88
			h ₇	l	l ₁	l ₂	s ₁	s ₂	s ₃	s ₄	s ₅	s ₆
MAG W 1300	200 ISO-F	mm	114	311 ¹⁾	311 ¹⁾	332 ¹⁾	42	140	0	15	241	98
		in.	4.49	12.24 ¹⁾	12.24 ¹⁾	13.07 ¹⁾	1.65	5.51	0	0.59	9.49	3.86
	200 CF	mm	114	307	307	-	32	164	0	-	-	98
		in.	4.49	12.09	12.09	-	1.26	6.46	0	-	-	3.86
MAG W 1600/1601/1700	250 ISO-F	mm	114	335	331	374	39	154	0	14	259	98
		in.	4.49	13.19	12.24	14.72	1.54	6.06	0	0.55	10.20	3.86
	250 CF	mm	114	335	322	-	29	173	0	9	285	98
		in.	4.49	13.19	12.68	-	1.14	6.81	0	0.35	11.22	3.86
MAG W 2200/2201	250 ISO-F	mm	114	343	340	392	34	165	0	12	272	98
		in.	4.49	13.50	13.39	15.43	1.34	6.50	0	0.47	10.71	3.86
	250 CF	mm	114	339	340	-	26	187	0	8	302	98
		in.	4.49	13.35	13.39	-	1.02	7.36	0	0.32	11.89	3.86

¹⁾ 4 mm (0.16 in.) for cooling coil

Dimensional drawing for the MAG INTEGRA, dimensions in mm

Advantages to the User

- Highest pumping speed and gas throughput from a very small size
- Rugged and reliable operation in industrial applications
- Sets new benchmarks for maintenance-free systems
- Suited for vibration sensitive applications in the areas of analytical, thin-film, electron microscopy, research and development among others.
- Flexibility through the modular concept; the converter is either attached to the side or under the pump

Technical Data

TURBOVAC MAG W

1300 iP(L) 1600 iP(L) 1601 iP(L) 1700 iP(L) 2200 iP(L) 2201 iP(L)
Booster Booster

Inlet flange	DN	200 ISO-F 200 CF	250 ISO-F	250 ISO-F	250 ISO-F 250 CF	250 ISO-F 250 CF	250 ISO-F
Pumping speed							
N ₂	l x s ⁻¹	1100	1600	1600	1610	2100	2100
Ar	l x s ⁻¹	1050	1470	1470	1480	1900	1900
He	l x s ⁻¹	1220	1770	1770	1710	2050	2050
H ₂	l x s ⁻¹	1130	1570	1570	1500	1750	1750
Operating speed							
standby speed adjustable from to nominal speed	min ⁻¹ min ⁻¹	37 800 13 800 (230 Hz)	33 000 13 800 (230 Hz)	33 000 13 800 (230 Hz)	33 000 13 800 (230 Hz)	30 600 13 800 (230 Hz)	30 000 13 800 (230 Hz)
Max. compression ratio							
N ₂		> 10 ⁸	> 10 ⁷	> 10 ⁷	> 10 ⁸	> 10 ⁸	> 10 ⁸
Ar		> 10 ⁸	> 10 ⁷	> 10 ⁷	> 10 ⁸	> 10 ⁸	> 10 ⁸
He at 1 sccm		2 x 10 ⁵	6 x 10 ⁴	3 x 10 ³	2 x 10 ⁵	5 x 10 ⁴	5 x 10 ³
H ₂ at 1 sccm		8 x 10 ³	1 x 10 ³	5 x 10 ²	4 x 10 ³	5 x 10 ³	5 x 10 ²
Max. gas throughput							
N ₂ briefly, e.g. during pumpdown	mbar x l x s ⁻¹	30	60	60	30	30	50
N ₂ in continuous operation	mbar x l x s ⁻¹	20	30	40	20	17	36
Ar briefly, e.g. during pumpdown	mbar x l x s ⁻¹	20	30	30	20	20	30
Ar in continuous operation	mbar x l x s ⁻¹	15	20	25	15	12	24
Ultimate pressure							
ISO-F flange	mbar (Torr)	< 10 ⁻⁸ (< 7.5 x 10 ⁻⁹)	< 10 ⁻⁸ (< 7.5 x 10 ⁻⁹)	< 10 ⁻⁸ (< 7.5 x 10 ⁻⁹)	< 10 ⁻⁸	< 10 ⁻⁸	< 10 ⁻⁸ (< 7.5 x 10 ⁻⁹)
CF flange	mbar (Torr)	< 10 ⁻¹⁰ (< 7.5 x 10 ⁻¹¹)	-	-	< 10 ⁻¹⁰ (< 7.5 x 10 ⁻¹¹)	< 10 ⁻¹⁰ (< 7.5 x 10 ⁻¹¹)	-
Max. degassing temperature °C (°F)							
80 (176)							
Max. foreline pressure							
N ₂	mbar (Torr)	4.0 (3.00)	1.0 (0.75)	1.0 (0.75)	4.0 (3.00)	2.5 (1.9)	1.2 (0.91)
Ar	mbar (Torr)	0.6 (0.45)	1.0 (0.75)	1.0 (0.75)	0.6 (0.45)	2.5 (1.9)	1.2 (0.91)
Recommended backing pump							
TRIVAC B or dry compressing pumps							
Run-up time min							
		< 5	< 7	< 7	< 7	< 10	< 10
Foreline flange DN							
40 KF							
Purge / vent port (clamped) DN							
16 KF							
Water cooling connection G							
1/8"							
Weight, approx. kg (lbs)							
		40 (88)	45 (99)	45 (99)	45 (99)	50 (110)	50 (110)
Noise level acc. ISO 3744 dB(A)							
< 41							
Vibration level at high vacuum flange at max. speed µm							
0.01							

High Vacuum Pumps

Technical Data

Integrated Frequency Converter

MAG.DRIVE iM

Power supply	V	200 - 240 ±10%
Mains frequency	Hz	50 / 60
Power consumption maximum	W	750
at ultimate pressure	W	150
Contact rating for the relays, max.		32 V, 0.5 A
Permissible ambient temperature during operation	°C (°F)	+10 to +45 (+50 to +113)
during storage	°C (°F)	-10 to +60 (+14 to +140)
Relative humidity of the air, non-condensing	%	5 to 85
Protection class	IP	54
Overvoltage category		II
Pollution category		2

Ordering Information

TURBOVAC MAG W1300/1600/1601/ 1700/2200/2201 iP(L)

TURBOVAC MAG W 1300 with Integrated Frequency Converter and Purge Gas Connection	P FC PS	Part No.	
MAG W 1300 iP, DN 200 ISO-F, Profibus		411300V0504	
MAG W 1300 iP, DN 200 ISO-F, 24 V SPS interface		411300V0514	
MAG W 1300 iP, DN 200 CF, Profibus		411300V0506	
MAG W 1300 iP, DN 200 CF, 24 V SPS interface		411300V0516	
MAG W 1300 iPL, DN 200 ISO-F, Profibus		411300V0704	
MAG W 1300 iPL, DN 200 ISO-F, 24 V SPS interface		411300V0714	
MAG W 1300 iPL, DN 200 CF, Profibus		411300V0706	
MAG W 1300 iPL, DN 200 CF 24 V SPS interface		411300V0716	
TURBOVAC MAG W 1600 Booster with Integrated Frequency Converter and Purge Gas Connection	P FC PS	Part No.	
MAG W 1600 iP Booster, DN 250 ISO-F, Profibus		411600V0504	
MAG W 1600 iP Booster, DN 250 ISO-F, 24 V SPS interface		411600V0514	
MAG W 1600 iPL Booster, DN 250 ISO-F, Profibus		411600V0704	
MAG W 1600 iPL Booster, DN 250 ISO-F, 24 V SPS interface		411600V0714	
TURBOVAC MAG 1601 Booster with Integrated Frequency Converter and Purge Gas Connection	P FC PS	Part No.	
MAG 1601 iP Booster, DN 250 ISO-F, Profibus		411600V2504	
MAG 1601 iP Booster, DN 250 ISO-F, 24 V SPS interface		411600V2514	
MAG 1601 iPL Booster, DN 250 ISO-F, Profibus		411600V2704	
MAG 1601 iPL Booster, DN 250 ISO-F, 24 V SPS interface		411600V2714	
TURBOVAC MAG W 1700 with Integrated Frequency Converter and Purge Gas Connection	P FC PS	Part No.	
MAG W 1700 iP, DN 250 ISO-F, Profibus		411700V0504	
MAG W 1700 iP, DN 250 ISO-F, 24 V SPS interface		411700V0514	
MAG W 1700 iP, DN 250 CF, Profibus		411700V0506	
MAG W 1700 iP, DN 250 CF, 24 V SPS interface		411700V0516	
MAG W 1700 iPL, DN 250 ISO-F, Profibus		411700V0704	
MAG W 1700 iPL, DN 250 ISO-F, 24 V SPS interface		411700V0714	
MAG W 1700 iPL, DN 250 CF, Profibus		411700V0706	
MAG W 1700 iPL, DN 250 CF, 24 V SPS interface		411700V0716	
TURBOVAC MAG W 2200 with Integrated Frequency Converter and Purge Gas Connection	P FC PS	Part No.	
MAG W 2200 iP, DN 250 ISO-F, Profibus		412200V0504	
MAG W 2200 iP, DN 250 ISO-F, 24 V SPS interface		412200V0514	
MAG W 2200 iP, DN 250 CF, Profibus		412200V0506	
MAG W 2200 iP, DN 250 CF, 24 V SPS interface		412200V0516	
MAG W 2200 iPL, DN 250 ISO-F, Profibus		412200V0704	
MAG W 2200 iPL, DN 250 ISO-F, 24 V SPS interface		412200V0714	
MAG W 2200 iPL, DN 250 CF, Profibus		412200V0706	
MAG W 2200 iPL, DN 250 CF, 24 V SPS interface		412200V0716	
TURBOVAC MAG 2201 Booster with Integrated Frequency Converter and Purge Gas Connection	P FC PS	Part No.	
MAG 2201 iP, DN 250 ISO-F, Profibus		412200V2504	
MAG 2201 iP, DN 250 ISO-F, 24 V SPS interface		412200V2514	
MAG 2201 iPL, DN 250 ISO-F, Profibus		412200V2704	
MAG 2201 iPL, DN 250 ISO-F, 24 V SPS interface		412200V2714	

Other interfaces upon request

With integrated Frequency Converter and Power Supply



MAG W 1300 iP(L),
 MAG W 1600/1601 iP(L) Booster,
 MAG W 1700 iP(L),
 MAG W 2200/2201 iP(L)

Ordering Information

**TURBOVAC MAG
 W1300/1600/1601/
 1700/2200/2201 iP(L)**

High
 Vacuum Pumps

Mandatory Accessories	P	Part No.
Set of bolts, nuts and washers for ISO-F flange (12 each) Bolts M 10 x 50 Bolts M 10 x 35		400153V0012 400153V0010
Centering with O-ring Al/FPM DN 200 DN 250 Stainless steel/FPM DN 200 DN 250		268 44 268 45 887 02 887 08
Set of bolts, nuts and washers for CF flange (8 each) Bolts M 8 x 40 (For DN 200, 3 sets are required; for DN 250, 4 sets)		400153V0016
Copper gasket rings for CF flange DN 200 (Set of 10 pieces) DN 250 (Set of 5 pieces)		839 47 839 48
Set of hex. bolts with nuts, bolts and washers for CF flange DN 200 DN 250 (2 sets required)		839 07 839 07
Accessories, optional	P FC PS	
Mains cable, 2.5 m (8.75 ft) with EURO plug with US plug		411310V03 411320V03
Seal Kit DN 250 Metal		200 07 901
Seal kit, metal, for other flanges		upon request
Purge gas and venting valve 24 V DC 0.6 mbar-l/s at 1.5 to 6 bar 0.6 mbar-l/s at 1 to 1.5 bar Cable set (2 pieces) for connection to the pump		121 33 800152V0010 411300V01
Cooling water valve kit		411300V02
Spare Parts Inlet screen DN 200 ISO-F and DN 200 CF DN 250 ISO-F and DN 250 CF		E 200 04 558 E 200 04 557
Included in the Delivery of the Pump	P	
Flanges for forevacuum, venting and purge gas are blank-flanged		
Converter-side mains plug (IP 54)		
Inlet screen		

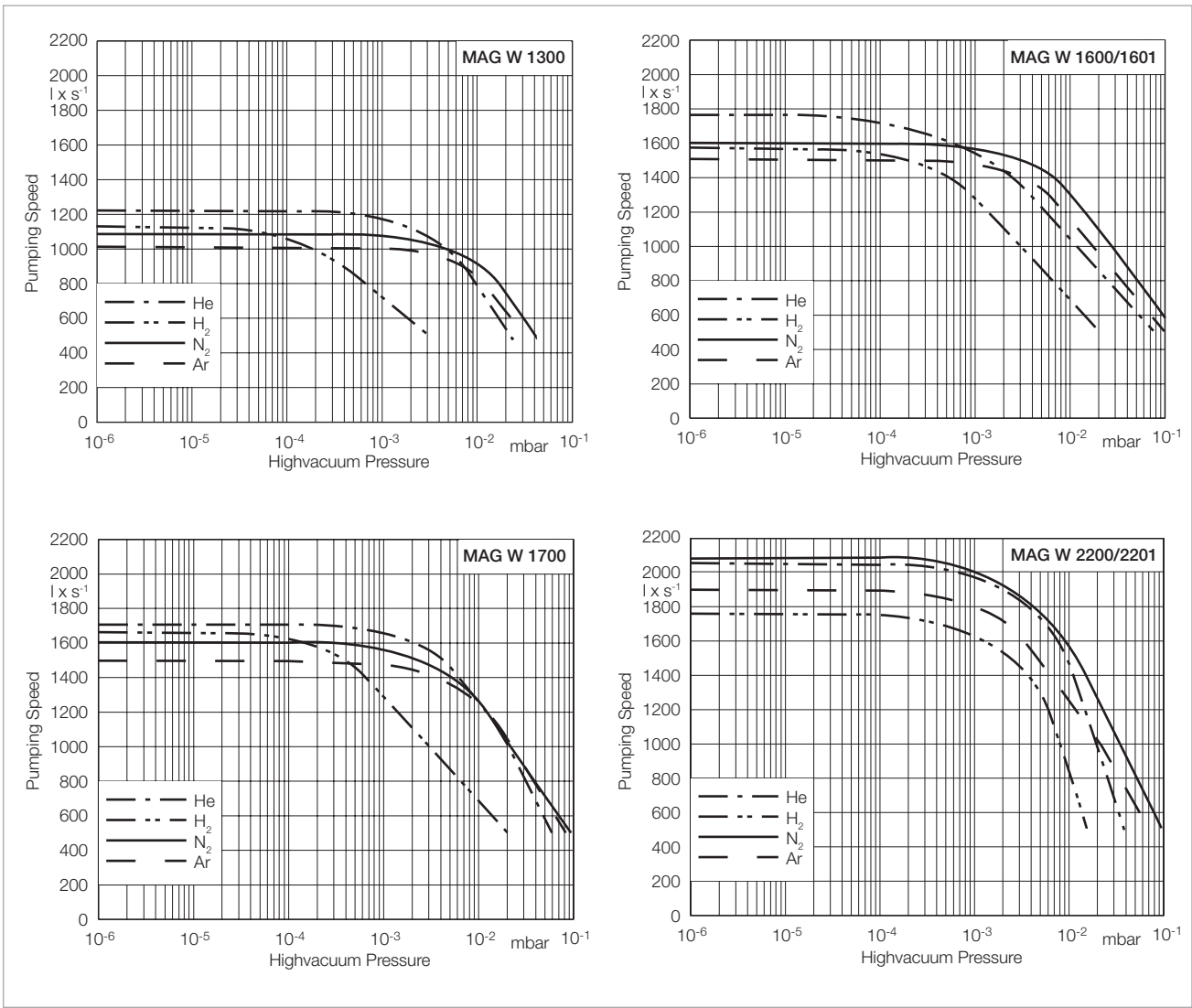

Pumping speed curves of the MAG W 1300, W 1600, W 1700 and W 2200

MAG INTEGRA - Magnetic Rotor Suspension with separate Frequency Converter, with Compound Stage

TURBOVAC MAG W 300/400 P



Typical Applications

- Gas analysis systems
- Particle accelerators
- Electron microscopes
- Research
- Coating systems

Technical Features

- Installation in any orientation
- DN 100 or 160 ISO-K and/or CF high vacuum connection
- DN 16 ISO-KF with clamped forevacuum connection
- Purge gas/venting connection DN 16 ISO-KF with clamped connection (purge/vent)
- Water or air cooling optional

Advantages to the User

- Highest pumping speed from the smallest possible size
- New standard regarding maintenance-free systems
- Suitability for vibration sensitive applications in the area of analytical engineering, thin-film technology, electron microscopes, research, development among others
- Flexibility due to the modular concept; alternatively the pump is available also with an integrated frequency converter

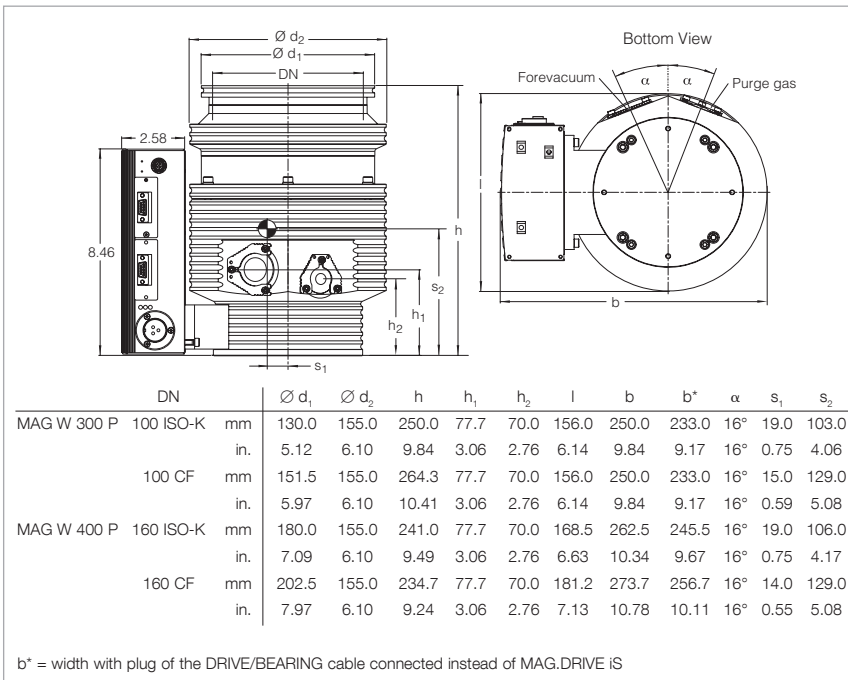

Dimensional drawing for the TURBOVAC MAG W 300/400 P

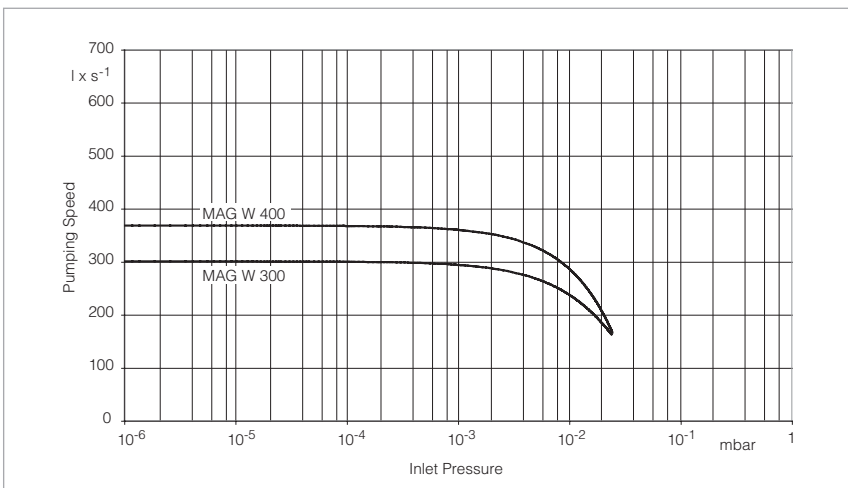

Pumping speed for N_2 of the TURBOVAC MAG W 300/400 P as a function of the inlet pressure

Technical Data

TURBOVAC MAG

W 300 P

W 400 P

Inlet flange	DN	100 ISO-K	100 CF	160 ISO-K	160 CF
Pumping speed					
N ₂	l x s ⁻¹	300	300	365	365
Ar	l x s ⁻¹	260	260	330	330
He	l x s ⁻¹	260	260	280	280
H ₂	l x s ⁻¹	190	190	200	200
Operating speed	min ⁻¹	58 800	58 800	58 800	58 800
Compression ratio					
N ₂		1.0 x 10 ¹⁰	1.0 x 10 ¹⁰	1.0 x 10 ¹⁰	1.0 x 10 ¹⁰
H ₂		3.2 x 10 ³	3.2 x 10 ³	3.2 x 10 ³	3.2 x 10 ³
He		9.2 x 10 ⁴	9.2 x 10 ⁴	9.2 x 10 ⁴	9.2 x 10 ⁴
Ultimate pressure	mbar (Torr)	< 10 ⁻⁸ (< 0.75 x 10 ⁻⁸)	< 10 ⁻¹⁰ (< 0.75 x 10 ⁻¹⁰)	< 10 ⁻⁸ (< 0.75 x 10 ⁻⁸)	< 10 ⁻¹⁰ (< 0.75 x 10 ⁻¹⁰)
Max. degassing temperature	°C (°F)	-	80 (176)	-	80 (176)
Max. foreline pressure for N ₂	mbar (Torr)	8 (6)	8 (6)	8 (6)	8 (6)
Recommended backing pump		TRIVAC D 2,5 E TRIVAC D 8 B	TRIVAC D 2,5 E TRIVAC D 8 B	TRIVAC D 2,5 E TRIVAC D 8 B	TRIVAC D 2,5 E TRIVAC D 8 B
Run-up time	min	< 5	< 5	< 5	< 5
Foreline flange (clamped)	DN	16 ISO-KF	16 ISO-KF	16 ISO-KF	16 ISO-KF
Purge / vent port (clamped)	DN	16 ISO-KF	16 ISO-KF	16 ISO-KF	16 ISO-KF
Water cooling connection (optional)	G	1/8"	1/8"	1/8"	1/8"
Weight, approx.	kg (lbs)	12 (26)	12 (26)	12 (26)	12 (26)



Technical Data

MAG.DRIVE S

Voltage range	V	100 - 240, ±10 %
Nominal frequency	Hz	50 / 60
Power consumption		
stand-by	W	100
maximum	W	400
Max. motor voltage	V	48
Max. pump current	A	6
Fuses F1, F2 5 x 20 mm		10 A fast blow high breaking capacity 250 V
System fuse		L or G characteristic
Max. frequency	Hz	0 to 2000
Load capability, relay output X1	V / A	32 / 0,5
Temperature		
during operation	°C (°F)	0 to +45 (+32 to +113)
during storage	°C (°F)	-10 to +60 (+14 to +140)
Relative humidity of the air	%	95 (non-condensing)

Ordering Information

TURBOVAC MAG W 300/400 P

TURBOVAC MAG W 300 P with separate Frequency Converter and Compound Stage	P	Part No.	
DN 100 ISO-K DN 100 CF		410300V0005 410300V0006	
TURBOVAC MAG W 400 P with separate Frequency Converter and Compound Stage	P		
DN 160 ISO-K DN 160 CF		410400V0005 410400V0006	
Mandatory Accessories		P	FC
Electronic frequency converter MAG.DRIVE S with display		410300V0212	
Connecting cable DRIVE/BEARING (connection between pump and MAG.DRIVE S) 3.0 m (10.5 ft) 5.0 m (17.5 ft) 10.0 m (35.0 ft) 20.0 m (70.0 ft)		410300V4003 410300V4005 410300V4010 410300V4020	
Mains cable 3.0 m (10.5 ft) EURO plug US plug 5-15 P 2.0 m (7.5 ft) US plug 115 V AC		800102V0002 800102V1002 992 76 513	
Forevacuum pump TRIVAC D 2,5 E 220-240 V, 50 Hz; 230 V, 60 Hz; Schuko plug, EURO version 110-120 V, 50/60 Hz; NEMA plug, US version		140 000 140 002	
TRIVAC D 8 B 1 phase motor; 230 V, 50/60 Hz 3 phase motor; 230/400 V, 50 Hz; 250/440 V, 60 Hz		112 55 112 56	

With separate Frequency Converter

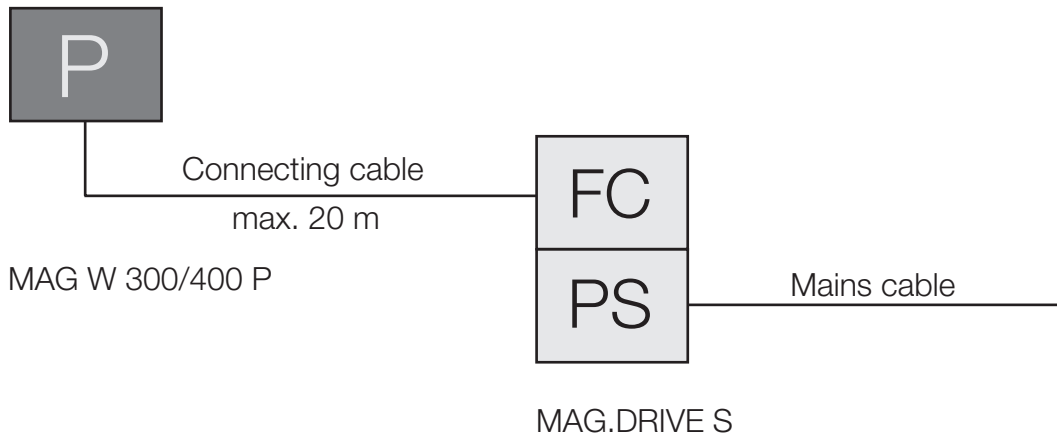

Ordering Information

TURBOVAC MAG W 300/400 P

Accessories, optional	P	Part No.
Inlet screen		
DN 100 ISO-K		
coarse (3.2 x 3.2 mm (0.13 x 0.13 in.))		800132V0101
fine (1.6 x 1.6 mm (0.06 x 0.06 in.))		800132V0102
DN 100 CF		
coarse (3.2 x 3.2 mm (0.13 x 0.13 in.))		200 91 514
fine (1.6 x 1.6 mm (0.06 x 0.06 in.))		E 200 17 195
DN 160 ISO-K		E 200 00 307
DN 160 CF		E 200 17 247
Flange heater		
100 CF, 230 V, 50 Hz		854 27
100 CF, 115 V, 60 Hz		854 28
160 CF, 230 V, 50 Hz		854 37
160 CF, 115 V, 60 Hz		854 38
Water cooling unit		410300V0101
Air cooling unit		410300V0102
Solenoid venting valve, normally closed		
24 V DC, DN 16 ISO-KF		800120V0011
Power failure venting valve, normally open		800120V0021
Included in the Delivery of the Pump	P	
Flanges for forevacuum, venting and purge gas are blank-flanged		
Centering ring with FPM sealing ring and a clamping yoke		

MAG INTEGRA - Magnetic Rotor Suspension with separate Frequency Converter, with Compound Stage

TURBOVAC MAG W 600/700 P



Typical Applications

- Gas analysis systems
- Particle accelerators
- Electron microscopes
- Research
- Coating systems

Technical Features

- Installation in any orientation
- DN 160 or 200 ISO-K and/or CF high vacuum connection
- DN 25 ISO-KF with clamped forevacuum connection
- Purge gas/venting connection DN 16 ISO-KF with clamped connection (purge/vent)
- Water or air cooling optional

Advantages to the User

- Highest pumping speed from the smallest possible size
- New standard regarding maintenance-free systems
- Suitability for vibration sensitive applications in the area of analytical engineering, thin-film technology, electron microscopes, research, development among others
- Flexibility due to the modular concept; alternatively the pump is available also with an integrated frequency converter

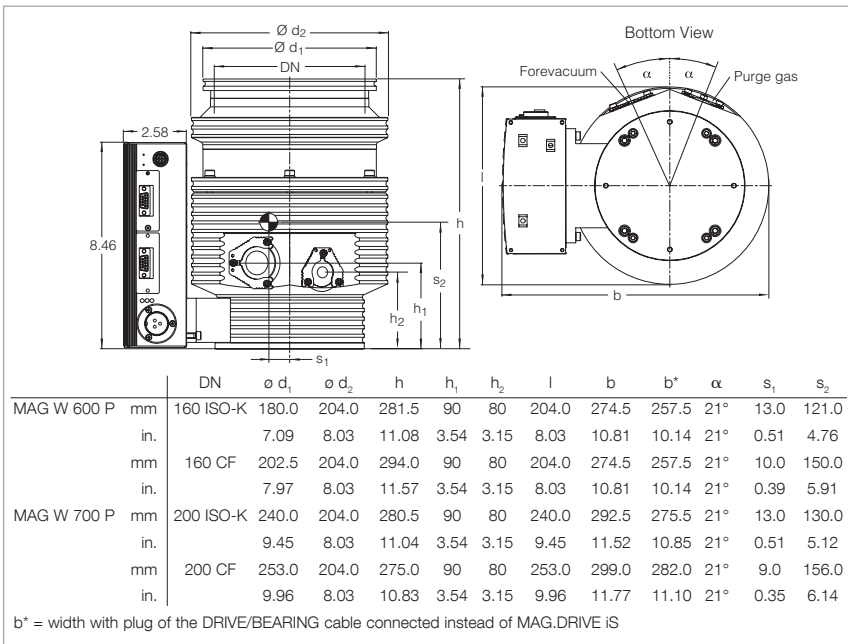

Dimensional drawing for the TURBOVAC MAG W 600/700 P

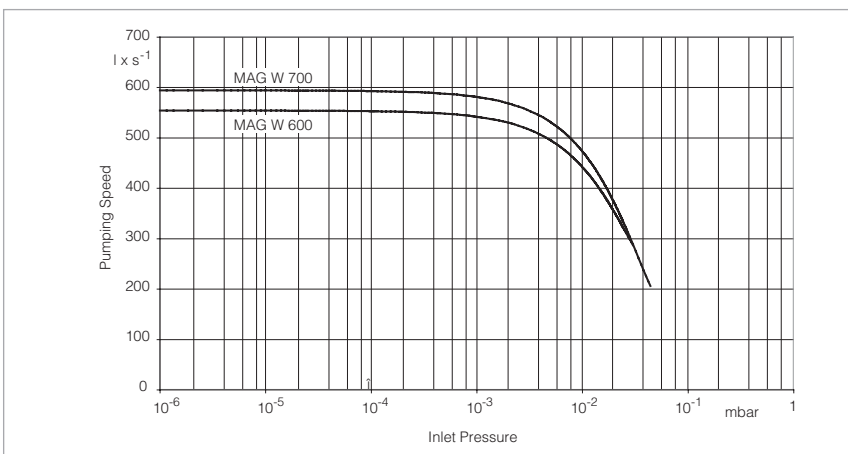

Pumping speed for N₂ of the TURBOVAC MAG W 600/700 P as a function of the inlet pressure

Technical Data

TURBOVAC MAG

W 600 P

W 700 P

Inlet flange	DN	160 ISO-K	160 CF	200 ISO-K	200 CF
Pumping speed					
N ₂	l x s ⁻¹	550	550	590	590
Ar	l x s ⁻¹	520	520	540	540
He	l x s ⁻¹	570	570	600	600
H ₂	l x s ⁻¹	410	410	430	430
Operating speed	min ⁻¹	48 000	48 000	48 000	48 000
Compression ratio					
N ₂		1.6 x 10 ¹⁰	1.6 x 10 ¹⁰	1.6 x 10 ¹⁰	1.6 x 10 ¹⁰
H ₂		3.4 x 10 ⁴	3.4 x 10 ⁴	3.4 x 10 ⁴	3.4 x 10 ⁴
He		1.7 x 10 ⁶	1.7 x 10 ⁶	1.7 x 10 ⁶	1.7 x 10 ⁶
Ultimate pressure	mbar (Torr)	< 10 ⁻⁸ (< 0.75 x 10 ⁻⁸)	< 10 ⁻¹⁰ (< 0.75 x 10 ⁻¹⁰)	< 10 ⁻⁸ (< 0.75 x 10 ⁻⁸)	< 10 ⁻¹⁰ (< 0.75 x 10 ⁻¹⁰)
Max. degassing temperature	°C (°F)	–	80 (176)	–	80 (176)
Max. foreline pressure for N ₂	mbar (Torr)	6.0 (4.5)	6.0 (4.5)	6.0 (4.5)	6.0 (4.5)
Recommended backing pump		TRIVAC D 2,5 E TRIVAC D 8 B	TRIVAC D 2,5 E TRIVAC D 8 B	TRIVAC D 2,5 E TRIVAC D 8 B	TRIVAC D 2,5 E TRIVAC D 8 B
Run-up time	min	< 6	< 6	< 6	< 6
Foreline flange (clamped)	DN	25 ISO-KF	25 ISO-KF	25 ISO-KF	25 ISO-KF
Purge / vent port (clamped)	DN	16 ISO-KF	16 ISO-KF	16 ISO-KF	16 ISO-KF
Water cooling connection (optional)	G	1/8"	1/8"	1/8"	1/8"
Weight, approx.	kg (lbs)	17 (37.5)	17 (37.5)	17 (37.5)	17 (37.5)



Technical Data

MAG.DRIVE S

Voltage range	V	100 - 240, ±10 %
Nominal frequency	Hz	50 / 60
Power consumption		
stand-by	W	100
maximum	W	400
Max. motor voltage	V	48
Max. pump current	A	6
Fuses F1, F2 5 x 20 mm		10 A fast blow high breaking capacity 250 V
System fuse		L or G characteristic
Max. frequency	Hz	0 to 2000
Load capability, relay output X1	V / A	32 / 0,5
Temperature		
during operation	°C (°F)	0 to +45 (+32 to +113)
during storage	°C (°F)	-10 to +60 (+14 to +140)
Relative humidity of the air	%	95 (non-condensing)

Ordering Information

TURBOVAC MAG W 600/700 P

TURBOVAC MAG W 600 P with separate Frequency Converter and Compound Stage	P	Part No.	
DN 160 ISO-K DN 160 CF		410600V0005 410600V0006	
TURBOVAC MAG W 700 P with separate Frequency Converter and Compound Stage	P		
DN 200 ISO-K DN 200 CF		410700V0005 410700V0006	
Mandatory Accessories	P FC		
Electronic frequency converter MAG.DRIVE S with display		410300V0212	
Connecting cable DRIVE/BEARING (connection between pump and MAG.DRIVE S)			
3.0 m (10.5 ft)		410300V4003	
5.0 m (17.5 ft)		410300V4005	
10.0 m (35.0 ft)		410300V4010	
20.0 m (70.0 ft)		410300V4020	
Mains cable			
3.0 m (10.5 ft) EURO plug		800102V0002	
US plug 5-15 P		800102V1002	
2.0 m (7.5 ft) US plug 115 V AC		992 76 513	
Forevacuum pump			
TRIVAC D 2,5 E			
220-240 V, 50 Hz; 230 V, 60 Hz; Schuko plug, EURO version		140 000	
110-120 V, 50/60 Hz; NEMA plug, US version		140 002	
TRIVAC D 8 B			
1 phase motor; 230 V, 50/60 Hz		112 55	
3 phase motor; 230/400 V, 50 Hz; 250/440 V, 60 Hz		112 56	

With separate Frequency Converter

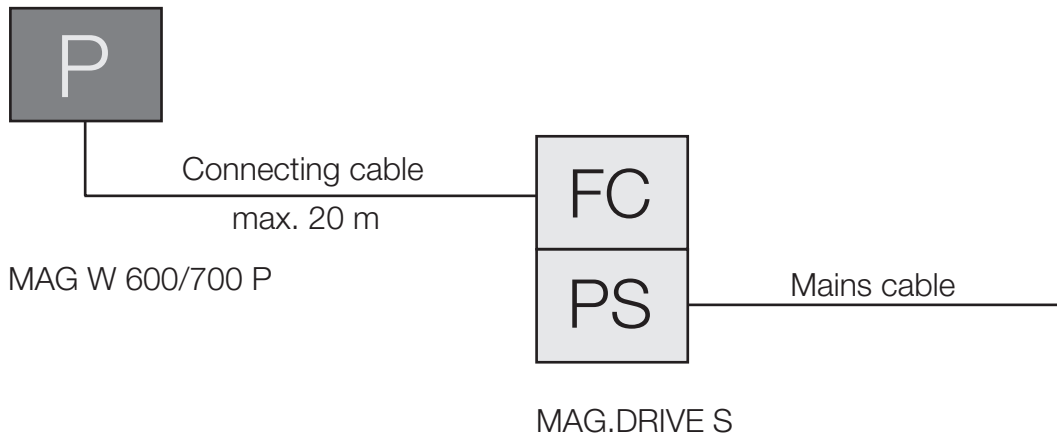

Ordering Information

TURBOVAC MAG W 600/700 P

Accessories, optional	P	Part No.
Inlet screen		
DN 160 ISO-K		E 200 00 307
DN 160 CF		E 200 17 247
DN 200 ISO-K		200 91 639
DN 200 CF		400 001 515
Flange heater		
160 CF, 230 V, 50 Hz		854 37
160 CF, 115 V, 60 Hz		854 38
Water cooling unit		410600V0101
Air cooling unit		410600V0102
Solenoid venting valve, normally closed		
24 V DC, DN 16 ISO-KF		800120V0011
Power failure venting valve, normally open		800120V0021
Included in the Delivery of the Pump	P	
Flanges for forevacuum, venting and purge gas are blank-flanged		
Centering ring with FPM sealing ring and a clamping yoke		

Accessories

Electronic Frequency Converters for Pumps with Mechanical Rotor Suspension

TURBO.DRIVE TD 20 *classic*



Technical Features

- For operating the TURBOVAC 151 (C), 361 (C), 600 C, 1000 C and 1100 C turbomolecular pump
- Front panel with LED
 - Status, Power, Error, pump run-up, pumping power
- Wide voltage range mains input
- Current interfaces like Profibus, DeviceNet, Ethernet/IP, RS 232 C, RS 485 C and 25-way terminal strip, available as options

Advantages to the User

- Easy integration within a vacuum system owing to the large variety of different modern interfaces as well as for modernising older systems
- Start/stop function through keys on the front panel
- Remote control and process control through analog and PLC compatible inputs and outputs
- Compatible to frequency converter NT 20, NT 151/361 and NT 361

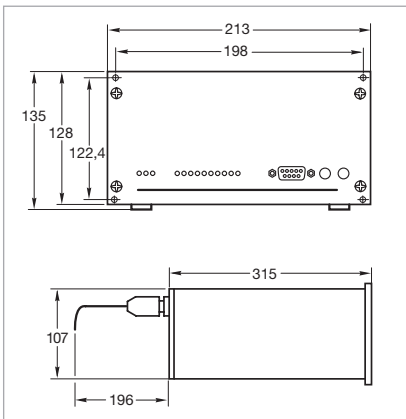

Dimensional drawing for the electronic frequency converter TURBO.DRIVE TD 20 *classic*

Technical Data

TURBO.DRIVE TD 20 *classic*

Mains connection	50/60 Hz	100 to 240 V (+15 % / -10 %)
Max. power consumption	W	500
Max. output voltage	V	3 x 47
Max. output current	A	5
Interface		Without, RS 232 C, RS 485 C, Profibus or 25-way terminal strip
Protection rating	IP	20
Admissible ambient temperature	°C (°F)	0 to +45 (+32 to +113)
Dimensions (W x H x D)	mm (in.)	213 x 128 x 315 (8.39 x 5.04 x 12.40)
Weight, approx.	kg (lbs)	4.0 (8.8)

Ordering Information

TURBO.DRIVE TD 20 *classic*

	Part No.
TURBO.DRIVE TD 20 <i>classic</i>	
without interface	800075V0001
with RS 232 C interface	800075V0002
with RS 485 C interface	800075V0004
with Profibus	800075V0003
with 25-pol I/O	800075V0005
Mains cable	
3 m (10.5 ft)	
EURO plug	800102V0002
UK plug	800102V0003
US plug 5-15 P	800102V1002
2 m (7.5 ft)	
US plug 115 V AC	992 76 513
Connecting cable	
TURBOVAC - frequency converter	
3 m (10.5 ft)	857 65
5 m (17.5 ft)	857 66
10 m (35.0 ft)	857 67
20 m (70.0 ft)	857 68
50 m (175.0 ft)	800152V0008
60 m (210.0 ft)	800152V0007
80 m (280.0 ft)	800152V0080
140 m (490.0 ft)	800152V0140
19" rack mounting frame 3 HU	161 00
Pump adapter cable	800 000 006
Adapter cable, 0.2 m (0.7 ft) long 25-way PLC interface to 2x Phoenix plugs (required when a NT 20 with connected PLC interface needs to be replaced)	800152V0020
PC software TURBO.DRIVE Server ¹⁾	800110V0102 (see Chapter "Accessories" at the end of the section)

¹⁾ Software supports only RS 232 C, RS 485 C and Profibus

TURBOTRONIK NT 10



Technical Features

- For operating the TURBOVAC 50 turbomolecular pump
- Bench top unit
- Also for rack mounting (1/4 19", 3 HU)
- Controls and indicators on the front panel
- Inputs for remote control and process controller
- Freely assignable relays (e.g. to control the backing pumps)

Technical Data

TURBOTRONIK NT 10

Mains connection	50/60 Hz	100-120 or 200-240 V
Max. power consumption	W	45
Max. output voltage	V	3 x 150
Max. output current	A	6
Protection rating	IP	20
Admissible ambient temperature	°C (°F)	0 to +40 (+32 to +104)
Dimensions (W x H x D)	mm (in.)	106 x 128 x 233 (4.17 x 5.04 x 9.17)
Weight, approx.	kg (lbs)	1.5 (3.3)

Ordering Information

TURBOTRONIK NT 10

	Part No.
100 - 120 V (with US plug)	859 01
200 - 240 V (with EURO plug)	859 00
Connecting cable pump - converter	
1 m (3.5 ft)	200 11 609
3 m (10.5 ft)	121 08
5 m (17.5 ft)	121 09
10 m (35.0 ft)	161 10
15 m (52.5 ft)	119 90
20 m (70.0 ft)	800150V2000

TURBO.DRIVE TD 400 (TD 400) for TURBOVAC SL 80



TURBO.DRIVE TD 400 (Front side)

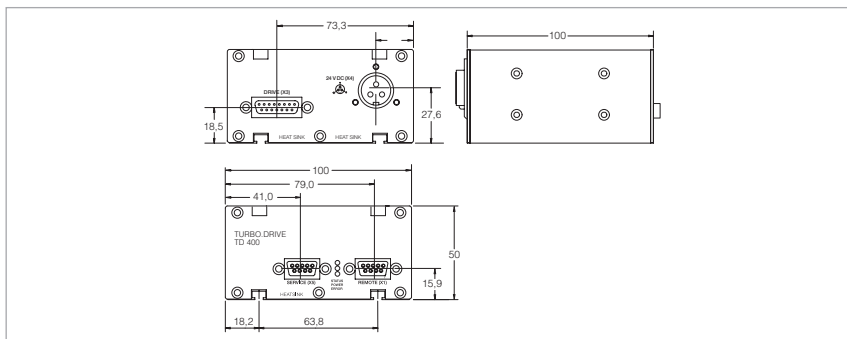

Dimensional drawing for the TURBO.DRIVE TD 400

Technical Features

- Small footprint
- USB, RS 232 C, RS 485 C, Profibus or Ethernet/IP interface
- Configurations:
 - as a separate frequency converter
 - integrated within the turbomolecular pump
- Remote control via remote interface
- Flexible mounting options
- Cost-effective supply of 24 V DC

High Vacuum Pumps

Technical Data

TURBO.DRIVE TD 400

Mains connection	V DC	24
Max. current consumption	A	8
Max. power consumption	W	190
Max. output voltage	V	3 x 24
Interface		USB, RS 232 C, RS 485 C or Profibus
Protection rating	IP	20
Admissible ambient temperature	°C (°F)	+5 to +45 (+41 to +113)
Dimensions (W x H x D)	mm (in.)	100 x 90 x 100 (3.9 x 3.5 x 3.9)
Weight, approx.	kg (lbs)	0.7 (1.6)

Ordering Information

TURBO.DRIVE TD 400

	Part No.
TURBO.DRIVE TD 400 with USB interface	800073V0008
with RS 232 C interface	800073V0002
with RS 485 C interface	800073V0003
with Profibus	800073V0004
Connecting cable TD 400 - Pump	
0.2 m (0.70 ft)	800152V0021
0.3 m (1.15 ft)	800152V0023
0.4 m (1.40 ft)	800152V0022
0.5 m (1.75 ft)	800152V0050
1.0 m (3.50 ft)	P152 47
2.5 m (8.75 ft)	864 49
3.0 m (10.5 ft)	864 40
5.0 m (17.5 ft)	864 50
START/STOP switch (for manual operation)	152 48
Hat rail adaptor as mounting aid	800110V0003
Accessories for RS 232 C and RS 485 C interfaces	(see Chapter "Accessories" at the end of the section)

TURBO.CONTROL 300

Power Supply Unit for TURBO.DRIVE TD 400

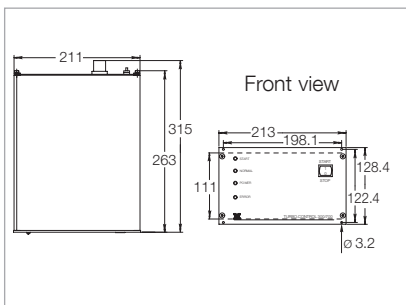

Dimensional drawing for the power supply
TURBO.CONTROL 300

Technical Features

- Cost-effective supply of 24 V DC power for SL 80 and TURBO.DRIVE TD 400
- Plug & play
- Bench top unit or for cabinet mounting
- Mains switch
- START/STOP switch for the turbo-molecular pump
- Remote control via remote interface
- Status indicating LEDs and status relays

Technical Data

Power Supply TURBO.CONTROL 300

Mains connection	50/60 Hz	85-264 V
Max. power consumption	W	300
Max. output voltage	V DC	24
Max. current consumption	A	8.4
Protection rating	IP	20
Admissible ambient temperature	°C (°F)	0 to +40 (+32 to +104)
Dimensions (W x H x D)	mm (in.)	213 x 129 x 320 (8.4 x 5.1 x 12.6)
Weight, approx.	kg (lbs)	1.5 (3.3)

Ordering Information

Power Supply TURBO.CONTROL 300

	Part No.
Power supply TURBO.CONTROL 300	800100V0001
DC cable frequency converter - power supply	24 V DC control cable
1 m (3.5 ft)	800091V0100
3 m (10.5 ft)	800091V0300
5 m (17.5 ft)	800091V0500
10 m (35.0 ft)	800091V1000
20 m (70.0 ft)	800091V2000
Mains cable	
3 m (10.5 ft) with EURO plug	800102V0002
with UK plug	800102V0003
with US plug 5-15 P	800102V1002
2 m (7.5 ft) US plug 115 V AC	992 76 513

Electronic Frequency Converters for Pumps with Magnetic Rotor Suspension MAG.DRIVE S



MAG.DRIVE S with display

Advantages to the User

- Operation of turbomolecular pumps with magnetically levitated rotors:
 - MAG W 300/400 P and
 - MAG W 600/700 P
- Easy operation through the controls
- Communication to host computer of the customer via serial interface and conventional interface possible
- Setting of speed and other functions
- Warning in case the pump is running out of specification
- Storing of all parameters in the pump's memory
- Small size and low weight
- Integrated fan
- 2 slots for industrial communications modules
 - rear side:
 - Standard 9 pin 24 V SPS
 - PLC-IO in Control Slot
 - front side:
 - RS 232 C in Service Slot
 - further interfaces can be fitted:
 - Ethernet, Profibus, DeviceNet, RS 485 C

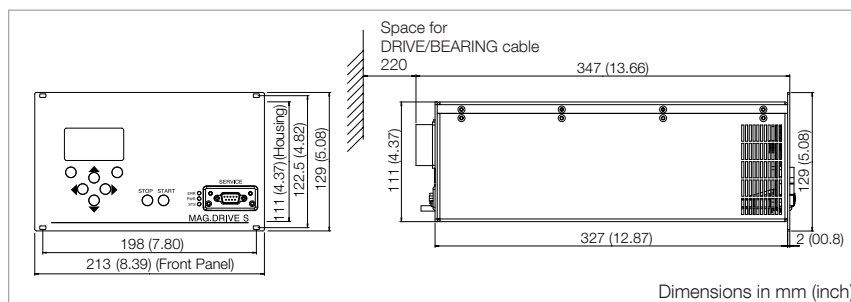

Dimensional drawing for the MAG.DRIVE S

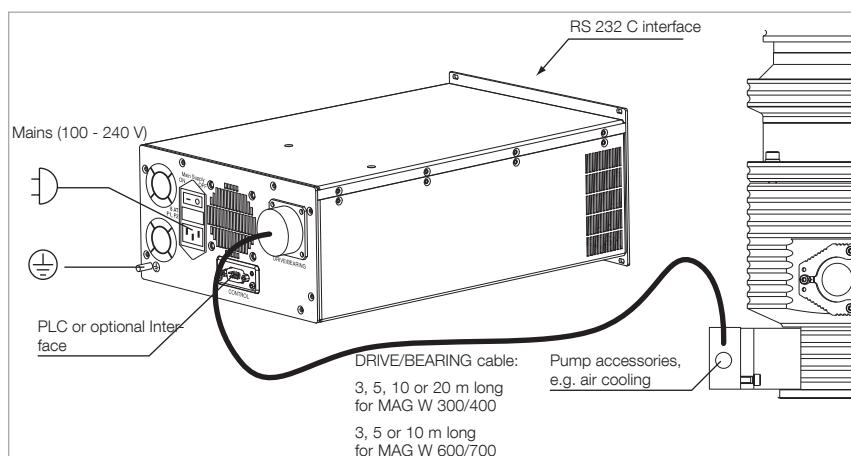

Connection schematic MAG.DRIVE S

Technical Data

MAG.DRIVE S

Voltage range	V	100 - 240, ± 10%
Nominal frequency	Hz	50 / 60
Power consumption		
stand-by	W	100
maximum	W	400
Max. motor voltage	V	48
Max. pump current	A	6
Fuses F1, F2 5 x 20 mm		10 A fast blow high breaking capacity 250 V
System fuse		L or G characteristic
Max. frequency	Hz	0 to 2000
Load capability, relay output X1	V / A	32 / 0,5
Temperature		
during operation	°C (°F)	0 to +45 (+32 to +113)
during storage	°C (°F)	-10 to +60 (+14 to +140)
Relative humidity of the air	%	95 (non-condensing)
Weight, approx.	kg (lbs)	65 (14.35)

Ordering Information

MAG.DRIVE S

	Part No.
Electronic frequency converter MAG.DRIVE S with display	410300V0212
Connecting cable DRIVE/BEARING (connection between pump and MAG.DRIVE S)	
3.0 m (10.5 ft)	410300V4003
5.0 m (17.5 ft)	410300V4005
10.0 m (35.0 ft) ¹⁾	410300V4010
20.0 m (70.0 ft) ¹⁾	410300V4020
Mains cable	
3.0 m (10.5 ft)	
EURO plug	800102V0002
US plug 5-15 P	800102V1002
2.0 m (7.5 ft)	
US plug 115 V AC	992 76 513

¹⁾ Suited for operating the MAG W 300/400 only

Power Supply TURBO.POWER 501

for TURBOVAC MAG W 300/400/600/700 iP



TURBO.POWER 501 (Fig.similar)

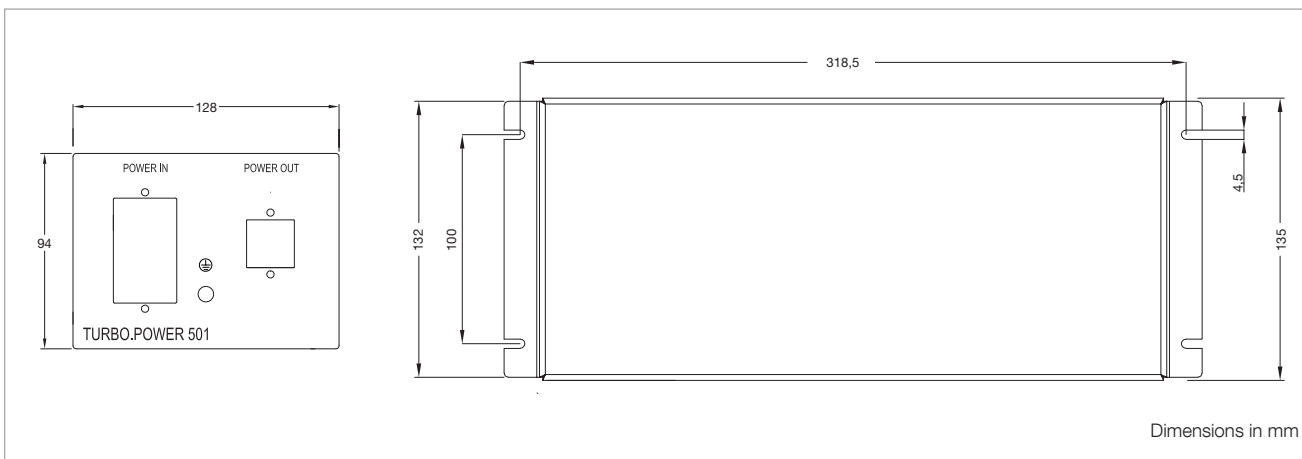

Dimensional drawing for the power supply TURBO.POWER 501

Technical Features

- For supplying 48 V DC power to the MAG W 300/400/600/700 iP
- Bench top unit or for cabinet mounting

Technical Data

Power Supply TURBO.POWER 501

Power supply (POWER IN)	V	100 - 240, ± 10%
Nominal frequency	Hz	50 / 60
Power consumption maximum	VA	650
at ultimate pressure operation of the pump	VA	450
DC voltage range POWER OUT	V DC	48
max.	A	10
Length of the DC connection cable, max.		
at 3 x 1.5 mm ²	m (ft)	5 (17.5)
at 3 x 2.5 mm ²	m (ft)	20 (70.0)
Ambient temperature during operation	°C (°F)	+10 to +40 (+50 to +104)
during storage	°C (°F)	-10 to -70 (+14 to -94)
Relative humidity of the air	%	5 to 85 (non-condensing)
Protection class	IP	30
Overvoltage category		II
Pollution category		2
Weight, approx.	kg (lbs)	4.0 (8.8)

Ordering Information

Power Supply TURBO.POWER 501

	Part No.
Power supply TURBO.POWER 500	410300V5221
DC cable (connection between TURBO.POWER 500 and MAG.DRIVE iS)	
1.0 m (3.5 ft)	410300V2001
3.0 m (10.5 ft)	410300V2003
5.0 m (17.5 ft)	410300V2005
10.0 m (35.0 ft)	410300V2010
20.0 m (70.0 ft)	410300V2020
Mains cable	
3.0 m (10.5 ft)	
EURO plug	800102V0002
US plug 5-15 P	800102V1002
2.0 m (7.5 ft)	
US plug 115 V AC	992 76 513

Vibration Absorber

Vibration absorbers are used to inhibit the propagation of vibrations from the turbomolecular pump to highly sensitive instruments like electron beam microscopes, micro-balances or analytical instruments.

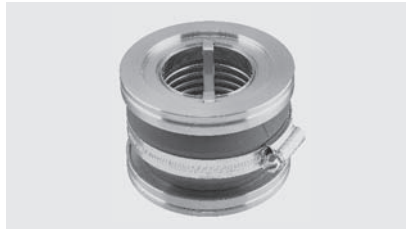

Ordering Information

Vibration Absorber

	Part No.
Vibration absorber	
DN 63 ISO-K 66 mm (2.60 in.) long	800131V0063
DN 63 CF 81 mm (3.19 in.) long	500 070
DN 100 ISO-K 84 mm (3.31 in.) long	800131V0100
DN 100 CF 100 mm (4.09 in.) long	500 071
DN 160 ISO-K 84 mm (3.31 in.) long	500 073
DN 160 CF 104 mm (4.09 in.) long	500 072

Air Cooling Unit for TURBOVAC ClassicLine Pumps

For the purpose of retrofitting the TURBOVAC 50, 151, 361 and 600 pumps for air cooling, an air cooling unit is available by way of a retrofit kit. This kit can be easily fitted to the respective pump using the fitting components included with the accessories.

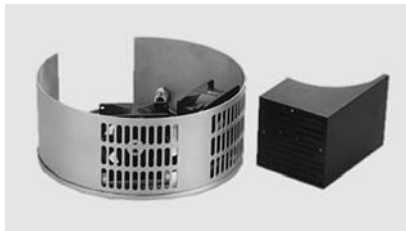

Technical Data

Air Cooling Unit

Rated power consumption of the air cooling unit when connected to		
TURBOVAC 50, 151 (C)/361 (C)	W	10.5
TURBOVAC 600 C, 1000 C	W	21.0

Ordering Information

Air Cooling Unit

	Part No.	Part No.
Air cooling unit for	230 V	100-115 V
TURBOVAC 50	854 05	800152V0015
TURBOVAC 1 51 (C)/361 (C)	855 31	800152V0016
TURBOVAC 600 C, 1000 C	855 41	800152V0017

Air Cooling Unit for TURBOVAC SL Pump

For fitting to the turbomolecular pump SL 80



Air cooling units for the pump SL 80

Technical Data

Power supply voltage	V DC
Current rating	mA
Power	W
Operating temperature	°C (°F)
Protection class	IP
Weight, approx.	kg (lbs)
Volume flow	m³/h

Air Cooling Unit

Power supply voltage	V DC	24
Current rating	mA	39
Power	W	0.9
Operating temperature	°C (°F)	+10 to +40 (+50 to +104)
Protection class	IP	20
Weight, approx.	kg (lbs)	0.23 (0.51)
Volume flow	m³/h	20

Ordering Information

Air Cooling Unit

	Part No.
Air cooling unit for TURBOVAC SL 80	800136V0001

Flange Heater for CF High Vacuum Flanges

Most TURBOVAC pumps can be baked out in order to improve the ultimate pressure attained in the UHV range. Degassing of the turbomolecular pump will only be useful when simultaneously baking out the vacuum chamber.



Technical Data

Flange Heater

Rated power consumption of the flange heater		
DN 63 CF, DN 100 CF	W	100
DN 160 CF	W	150

Ordering Information

Flange Heater

	Part No.	Part No.
Flange heater	230 V	115 V
DN 63 CF	854 04	854 07
DN 100 CF	854 27	854 28
DN 160 CF	854 37	854 38

Fine Filter

A fine filter integrated in the centering ring protects the pump against particles and dust on the high vacuum side.



Ordering Information

Fine Filter

	Part No.
Connection flange of the fine filter	
DN 40 ISO-KF	883 98
DN 63 ISO-K	887 20
DN 100 ISO-K	887 21

Securing Collar for Octal Socket Plugs

for ClassicLine Pumps TURBOVAC 151 (C), 361 (C), 600 C, 1000 C and 1100 C

The securing collar serves the purpose of securing the plug on the ClassicLine pumps TURBOVAC 151 (C), 361 (C), 600 C, 1000 C and 1100 C against being disconnected inadvertently.



Ordering Information

Securing Collar for Octal Socket Plugs

	Part No.
Securing collar for octal socket plugs	800001830

Solenoid Venting Valve

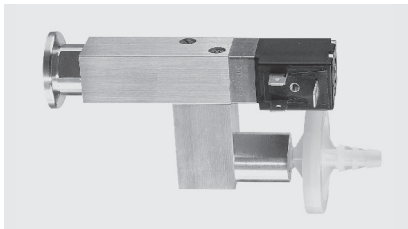

Technical Data

Venting Valve

Drive voltage	V DC	24
Power consumption	W	4
Connecting flange	DN	16 ISO-KF
Weight, approx.	kg (lbs)	0.3 (0.66)

Ordering Information

Venting Valve

	Part No.
Solenoid venting valve, normally closed	800120V0011

Power Failure Venting Valve

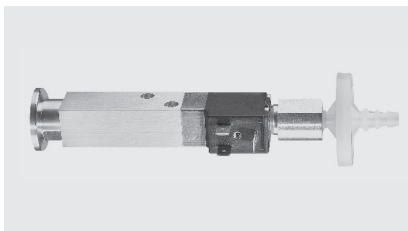

Technical Data

Power Failure Venting Valve

Drive voltage	V DC	24
Power consumption	W	4
Connecting flange	DN	16 ISO-KF
Weight, approx.	kg (lbs)	0.3 (0.66)

Ordering Information

Power Failure Venting Valve

	Part No.
Power failure venting valve, normally open	800120V0021

Power Failure Venting Valve, Electromagnetically Actuated

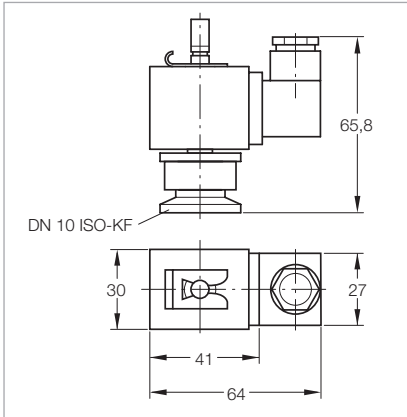

Dimensional drawing for the electromagnetically actuated power failure venting valve

Technical Data

Technical data

Power Failure Venting Valve

See Catalog "Valves", para. "Special Valves"

Ordering Information

Power failure venting valve DN 10 ISO-KF,
electromagnetically actuated
24 V DC
230 V AC / 50/60 Hz

Power Failure Venting Valve

Part No.

174 46
174 26

Purge Gas and Venting Valve



Technical Data

Connecting flange DN
Weight, approx. kg (lbs)

Purge Gas and Venting Valve

10 ISO-KF
0.7 (1.55)

Ordering Information

Purge gas and venting valve, 230 V
0.2 mbar x l x s⁻¹ (12 sccm)
0.4 mbar x l x s⁻¹ (24 sccm)

Purge Gas and Venting Valve

Part No.

855 19
855 29

Purge Gas and Venting Valve

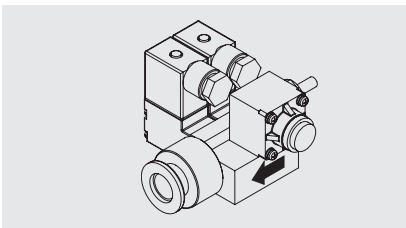

Technical Data

Connecting flange
Inlet
Outlet
Purge gas pressure, abs. bar
Weight, approx. kg (lbs)

Purge Gas and Venting Valve

1/4" tube
pump specific or DN 16 ISO-KF

1.5 to 6,0
0.5 (1.1)

Ordering Information

Purge gas and venting valve, 24 V DC
0.6 mbar x l x s⁻¹

Purge Gas and Venting Valve

Part No.

121 33

Further 0.6 mbar x l x s⁻¹ valves upon request

Purge Gas and Venting Valve for ClassicLine and SL Pumps



Technical Data

Technical Data		Purge Gas and Venting Valve
Connecting flange		
Pump side	DN	10 ISO-KF
Gas connection	G	1/4"
Seal gas pressure, abs.	bar	1
Weight, approx.	kg (lbs)	0.3 (0.66)

Ordering Information

Purge Gas and Venting Valve

	Part No.
Purge gas and venting valve at 1 bar	113 50
0.2 mbar x l x s ⁻¹ (12 sccm), 24 V DC	800152V0041
0.2 mbar x l x s ⁻¹ (12 sccm), 110 - 115 V AC	800152V0019
0.2 mbar x l x s ⁻¹ (12 sccm), 230 V AC	800152V0013
0.4 mbar x l x s ⁻¹ (24 sccm), 24 V DC	800152V0042
0.4 mbar x l x s ⁻¹ (24 sccm), 110 - 115 V AC	800152V0014
0.4 mbar x l x s ⁻¹ (24 sccm), 230 V AC	800152V0012
0.6 mbar x l x s ⁻¹ (36 sccm), 24 V DC	800152V0043
0.6 mbar x l x s ⁻¹ (36 sccm), 110 - 115 V AC	800152V0040
0.6 mbar x l x s ⁻¹ (36 sccm), 230 V AC	

Adapter Set for Seal Gas and Venting Valve for the SL pumps

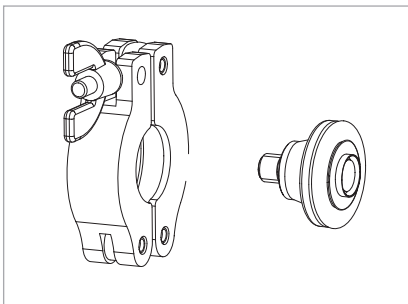

Technical Data

Technical Data	Adapter Set
Pump flange adapter incl. adapter centering ring with sinter filter insert and clamping ring	M8 / DN 10 ISO-KF DN 10 / DN 16 ISO-KF

Ordering Information

Adapter Set

	Part No.
Adapter set for purge gas and venting valve	800110V0011

Gas Filter to G 1/4" for Purge Gas and Venting Valve

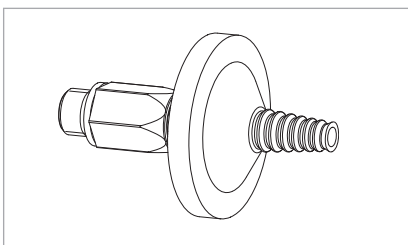

Technical Data

Technical Data	Gas Filter
Gasfilter including fitting G 1/4" and 2 gaskets	

Ordering Information

Gas Filter

	Part No.
Gas filter to G 1/4" for seal gas and venting valve	800110V0012
Replacement filter for gas filter to G 1/4" for seal gas and venting valve	E 200 18 515

Accessories for Serial Interfaces RS 232 C and RS 485 C

Through these accessories many control, monitoring and information capabilities can be implemented in

connection with the electronic frequency converters and turbomolecular pumps.

All turbomolecular pumps or electronic frequency converters are supported.

PC Software LEYASSIST



Software for PC-based communication, control and monitoring of turbomolecular pumps via USB, RS 485 or RS 232 interface with automatic pump detection.

Functions

- Display of vacuum system status
- Configuring the accessory functions of the TURBOVAC i / iX
- Reading/writing of parameters
- Data logging
- Alarm/warning message logging

Ordering Information

PC Software LEYASSIST

	Part No.
PC software LEYASSIST	230439V01

Interface Adaptor for Frequency Converter with RS 232 C/RS 485 C Interface

Ordering Information

Interface Adaptor RS 232 C/RS 485 C

	Part No.
Adaptor RS 232 C/RS 485 C mains connection 230 V, 50 Hz, EURO plug	800110V0101
Adaptor USB/RS 232 C for connection of RS 232 C to USB (PC), including CD with drivers and manual	800110V0103

Miscellaneous

Services for Mechanically Suspended Turbomolecular Pumps

Complete Refurbishing at the Service Centre

Complete refurbishing at the service centre includes the following:

Complete disassembly, cleaning, replacement of all wearing parts, mounting, electrical safety test, final test including vibration measurement

Complete Refurbishing with Decontamination at the Service Centre

Complete refurbishing with decontamination at the service centre includes the following:

Complete disassembly, cleaning and decontamination, replacement of all wearing parts, mounting, electrical safety test, final test including vibration measurement

Ordering Information

Complete Refurbishing at the Service Centre

Complete Refurbishing with Decontamination at the Service Centre

	Part No.	Part No.
For pump		
TURBOVAC 35 / 50D	AS 2165	AS 2165 D
TURBOVAC 50	AS 2133	AS 2133 D
TURBOVAC SL 80	LAS 2368	LAS 2368 D
TURBOVAC TW 70 H	AS 2368	AS 2368 D
TURBOVAC 151	AS 2134	AS 2134 D
TURBOVAC TW 250 S	AS 2168	AS 2168 D
TURBOVAC SL 300	LAS 2369	LAS 2369 D
TURBOVAC TW 300	AS 2369	AS 2369 D
TURBOVAC 361	AS 2135	AS 2135 D
TURBOVAC 600 / 1000	AS 2136	AS 2136 D
TURBOVAC TW 701 / 690	AS 2330	AS 2330 D
TURBOVAC 1100	AS 2137	AS 2137 D

Services for Magnetically Levitated Turbomolecular Pumps

Complete Refurbishing at the Service Centre

Complete refurbishing at the service centre includes the following:

Complete disassembly, cleaning, replacement of all wearing parts, mounting, electrical safety test, final test including vibration measurement

Complete Refurbishing with Decontamination at the Service Centre

Complete refurbishing with decontamination at the service centre includes the following:

Complete disassembly, cleaning and decontamination, replacement of all wearing parts, mounting, electrical safety test, final test including vibration measurement

Ordering Information

Complete Refurbishing at the Service Centre

Complete Refurbishing with Decontamination at the Service Centre

	Part No.	Part No.
For pump		
MAG W 300 / 400	AS 2300	AS 2300 D
MAG W 600 / 700	AS 2600	AS 2600 D
MAG W 1300 iP (L) - 2201 iP (L)	AS 2700	AS 2700 D
MAG (W) 1600 / 2000	AS 2164 ¹⁾	AS 2164 D ¹⁾
MAG (W) 830 / 1300 / 1500	AS 2370 ¹⁾	AS 2370 D ¹⁾
MAG 900 / 1000 / 1200	AS 2160 ¹⁾	AS 2160 D ¹⁾
MAG 2200	AS 2200 ¹⁾	AS 2200 D ¹⁾
MAG 2800 / 3200	AS 2800 ¹⁾	AS 2800 D ¹⁾

Notes

The listed services include the costs for material and working hours for standard pumps. Services for pump variants upon request.

If additional spare parts are needed for repairs, then these are invoiced separately according to a cost estimate.

¹⁾ Including rotor replacement

General

Applications and Accessories for Oil Diffusion Pumps

Pumps	DIP 3000	DIP 8000	DIP 12000	DIP 20000	DIP 30000	DIP 50000	LEYBOJET 630	OB 6000	OB 12000	OB 18000
Application										
Vacuum coating (e.g. Sputtering)	■	■	■	■	■	■	■	■	■	■
Research and development	■	■	■	■	■	■	■	■	■	■
Metallurgy/furnaces	■	■	■	■	■	■	■	■	■	■
Mechanical engineering	■	■	■	■	■	■	■	■	■	■
Sputtering process							■	■	■	■
Secondary metallurgy (e.g. VIM, VID)								■	■	■
High vacuum furnaces								■	■	■

Accessories

Page

Astrotorus baffle	450	■	■	■	■	■	■	■			
Over-temperature protection switch	452	■	■	■	■	■	■	■			
Contact thermometer	452	■	■	■	■	■	■	■			
Resistance thermometer Pt100	452	■	■	■	■	■	■	■			
Monitoring instruments	453	■	■	■	■	■	■	■	■	■	■
Power controller	454				■	■	■	■	■	■	■
Adsorption trap	456	For generating an oil-free vacuum with oil sealed backing pumps									

Oil for Diffusion Pumps for different fields of application

Application	Vacuum coating	Research and development	Metallurgy/furnaces	Mechanical engineering	Sputter processes
LEYBONOL Oils					
LVO 500	■	■	■	■	■
LVO 510	●	●	●	●	●
LVO 520	●	●			
LVO 530	●	●			
LVO 540 ¹⁾	■	■	■	■	■

- = Standard
- = Possible

¹⁾ Only for OB pumps

The table only lists general applications. Your specific requirements might be subject to deeper analysis. For further questions, please contact our technical Sales support.

For information on oil specifications please refer to Catalog Part "Oils / Greases / Lubricants LEYBONOL®".

Oil for Diffusion Pumps for different pump types

Pumps	DIP 3000	DIP 8000	DIP 12000	DIP 20000	DIP 30000	DIP 50000	LEYBOJET 630	OB 6000	OB 12000	OB 18000
LEYBONOL Oils										
LVO 500	■	■	■	■	■	■	■			
LVO 510	●	●	●	●	●	●	●			
LVO 520	●	●	●	●	●	●	●			
LVO 530	●	●	●	●	●	●	●			
LVO 540								■	■	■

- = Standard
- = Possible

Note

All oils may be used.
The pumps are supplied as standard without oil.

The table only lists general applications. Your specific requirements might be subject to deeper analysis.
For further questions, please contact our technical Sales support.

**For information on oil specifications please refer to Catalog Part
“Oils / Greases / Lubricants LEYBONOL®”.**

Operating Principle of Fluid Entrainment Vacuum Pumps

The main components of diffusion pumps, the operation of which relies on vapor-phase pump fluids are:

- Cooled pump body with intake and exhaust ports
- System of nozzles
- Pump boiler

In the case of diffusion pumps a pump fluid contained in a boiler is heated to such an extent that it is vaporized. The vapor is then forced through nozzles within the pump. The nozzles are generally designed in such a way, that they accelerate the vapor to a speed exceeding the speed of sound (Laval nozzles), thus creating a high speed vapor jet. The vapor is then deflected by the nozzles at a specific angle onto the pump body. The pump body is

cooled, so that the vaporized pump fluid condenses and is returned back to the boiler as a liquid. The pumping action of diffusion pumps and fluid entrainment pumps in general is based on the transporting capacity of the vapor jet.

The gas which is to be pumped is compressed sufficiently at the fore-vacuum port so that it can be pumped out by a backing pump.

Oil Diffusion Pumps

Compared to other fluid entrainment pumps the density of the vapor in the boiler and in the vapor jet is fairly low so that the gas molecules may almost completely diffuse into the vapor jet. Thus most of the molecules which enter the vapor jet are also pumped out.

For this reason, the pumping speed of diffusion pumps is extremely high with respect to the intake area and constant – starting at an inlet pressure of approx. 10^{-3} mbar (0.75×10^{-3} Torr) down to very low pressures – as within the pressure range the vapor jet is not influenced in any way by the pressure within the vacuum vessel.

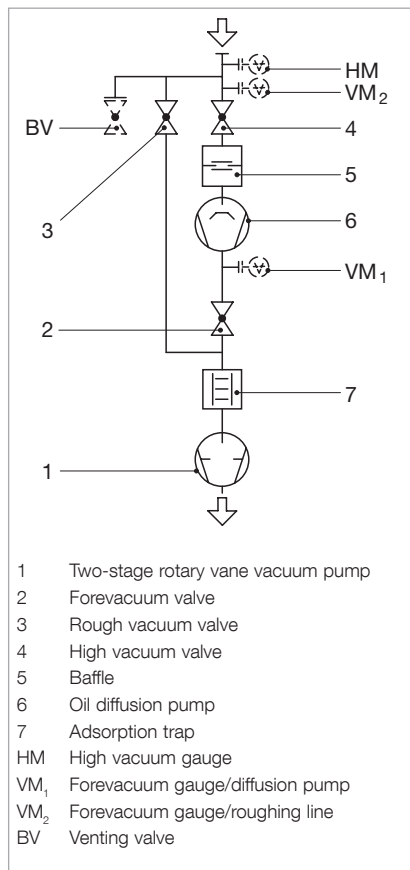

Diagram of a pump system with diffusion pump

Operating Oil Diffusion Pumps

Forevacuum

In all cases diffusion pumps require a sufficiently sized backing pump (see Technical Data). The size and type of forevacuum pump depends on the operating conditions and the quantities of gas which are to be pumped.

1. Continuous operation at operating pressures above 10^{-4} mbar (0.75×10^{-4} Torr) – large quantities of gas.
2. Continuous operation at operating pressures below 10^{-4} mbar (0.75×10^{-4} Torr) – smaller quantities of gas.

In applications which rely on diffusion pumps, the vacuum chamber must be connected via a valve (3) and a roughing line directly to the backing pump. This is done so that the vacuum chamber may be pre-evacuated by the backing pump down to a pressure where the diffusion pump can take over. Until the high vacuum valve (4) opens, both diffusion pump and pump fluid are preserved. Before venting the vacuum chamber the forevacuum valve (2) and the high vacuum valve (4) must be closed, whereby the diffusion pump remains in the ready status.

Pumping Speed

The pumping speed of any pump is equivalent to the volume throughput through the intake opening of a pump. In the case of diffusion pumps the pumping speed for lighter gases is higher compared to heavier gases.

Backstreaming of the Pump Fluid

Undesirable backstreaming of molecules from the pump fluid is caused by the effect that some molecules are able to leave the vapor jet and thus do not arrive at the cooled pump body. Because of collisions between each other and due to reflection at the pump body, these molecules are then able to move in the direction of the vacuum chamber.

For DIP pumps the backstreaming effect amounts only to a few μg per cm^2 of intake area per minute. Backstreaming may be almost completely suppressed by including a cold cap baffle or an additional Astrotorus baffle.

Backstreaming of Oil in the Case of Diffusion Pumps

- Pump without baffle
approx. $1 \times 10^{-2} \text{ mg} \times \text{cm}^{-2} \times \text{min}^{-1}$
- Pump with cold cap baffle
approx. $1 \times 10^{-3} \text{ mg} \times \text{cm}^{-2} \times \text{min}^{-1}$
- Pump with Astrotorus baffle
($T = 10 \text{ }^\circ\text{C}$ ($50 \text{ }^\circ\text{F}$))
approx. $1 \times 10^{-5} \text{ mg} \times \text{cm}^{-2} \times \text{min}^{-1}$

The values stated have been measured at an intake pressure of $< 1 \times 10^{-4}$ mbar and apply to LEYBONOL LVO 500.

Attainable Ultimate Pressure

The attainable ultimate pressure for a particular vacuum system depends not only on the type and pumping speed rating of the diffusion pump, but also on the vapor pressure of the pump fluid, shape and temperature of the baffle, leaks at connecting flanges or welded joints and the condition of the surfaces within the vacuum chamber.

When excluding all effects which contribute to an increase in pressure within

the vacuum chamber due to leaks and contamination of the vacuum chamber walls, it will be possible to attain the ultimate pressures stated in the table "Attainable Ultimate Pressures with Oil Diffusion Pumps (DIP)" given in chapter "General".

In practice the following combination has been found to work very well when needing a low vacuum free of oil vapors.

- Water-cooled cold cap baffle as a integral part of the diffusion pump together with a water-cooled Astrotorus baffle which may be installed as an additional component on the high vacuum flange of the diffusion pump.

Sealing Methods

For ultimate pressures down to 10^{-8} mbar (0.75×10^{-8} Torr) bakeout temperatures of up to 150 °C (302 °F) are sufficient. FPM [FKM (= Fluor caoutchouc), temperature resistant up to 150 °C (302 °F)] sealing rings or ultra sealing rings made of aluminum must be used.

In order to prevent pressure variations, ultra sealing rings must be used in the connections, between diffusion pump and baffle.

Ultimate pressures below 10^{-8} mbar (0.75×10^{-8} Torr) require bakeout temperatures up to 400 °C (752 °F). However, it is only necessary to bake out the vacuum chamber to 400 °C (752 °F) and to maintain a temperature gradient across the baffle or the cold trap so that a temperature of 150 °C (302 °F) is not exceeded at the intake flange of the pump.

In this way, it is still acceptable to use FPM (FKM) sealing rings or ultra sealing rings made of aluminium.

Cooling

The cooling water temperature should not exceed 25 °C (77 °F) at the intake and 30 °C (86 °F) at the discharge, otherwise sufficient condensation of the pump fluid cannot be ensured. When connecting the cooling system of the pump and the baffle in series, the cooling water must always be made to flow through the baffle first and then through the diffusion pump, because the attainable ultimate pressure in the vacuum chamber depends strongly on the condensation temperature of the pump fluid in the baffle.

Attainable Ultimate Pressures with Oil Diffusion Pumps

Attainable Ultimate Pressure ¹⁾

LEYBONOL LVO 500

Without baffle	mbar (Torr)	1.5×10^{-6} (1.1×10^{-6})
With cold cap baffle	mbar (Torr)	5.0×10^{-7} (3.8×10^{-7})
With Astrotorus baffle	mbar (Torr)	1.5×10^{-7} (1.1×10^{-7})

¹⁾ Attained in consideration of the notes given under "Sealing Methods" in the chapter "General" para. "Oil Diffusion Pumps" and after degassing the connected vacuum chamber for several hours at 200 °C (392 °F)

Products

DIP Pumps Water-Cooled



DIP 12 000



DIP 30 000 with Power Controller

The DIP range of pumps was developed for operation in industrial systems. Excellent vacuum performance data combined with the inherent ruggedness of this kind of pump, make our diffusion pumps a reliable component in high and medium vacuum applications.

Advantages to the User

- High pumping speeds in the fine and high vacuum ranges
- Low attainable ultimate pressure
- Integrated, water-cooled cold cap baffle guarantees low oil back-streaming rates into the vacuum chamber
- Low oil losses (even at high gas throughputs) by integrated water-cooled forevacuum baffle
- High forevacuum resistance even at reduced heating power
- The heating cartridges are accessible from the outside via heating inserts which are built into the boiler. This ensures a quick exchange of single heating cartridges (even when the pump is hot)
- A separate automatic circuit breaker for each heating cartridge ensures a high level of electrical safety
- A standard built-in thermostat acts as a thermal overload switch and ensures that the heating cartridges can not overheat
- All pumps are prepared for installation with an over-temperature switch (optional) for checking the cooling water circuit, and a contact thermometer (optional) to monitor the operating temperature of the diffusion pump
- Indication of the oil level by sight-glass permits simple checking of the current oil level
- All DIP pumps are delivered with their inside chamber cleaned in such a manner that it is free of oil. The inside is evacuated. In the condition as delivered, the pumps may be also operated with silicone oil
- Utilisation of the DIP power controller cuts power consumption by up to 30% without impairing pump performance (option)

Typical Applications

The diffusion pumps from the DIP range are used in coating systems, vacuum melting and drying systems as well as in vacuum furnaces in the area of metallurgy.

Supplied Equipment

The DIP pumps are supplied ready for connection but without the filling of pump fluid.

The inside of the pump is cleaned before delivery to such an extent that it is free of oil. The inside is evacuated. High and forevacuum flanges are equipped with gaskets and centering rings having shipping flanges and complete with clamping components.

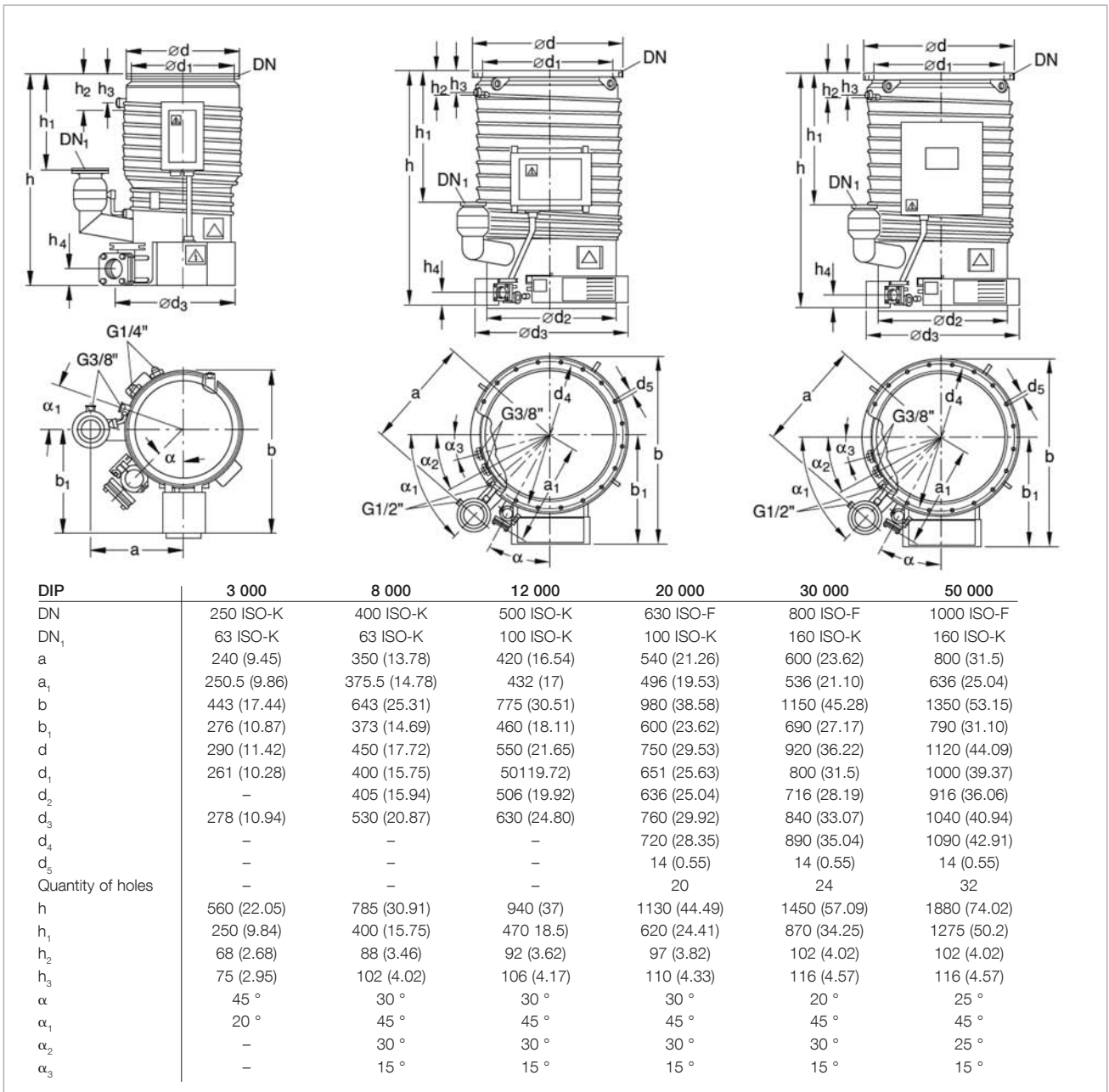

Dimensional drawing for the DIP 3000 [left], DIP 8000 and DIP 12000 [middle], DIP 20 000 to DIP 50 000 [right]; dimensions in brackets () are in inch

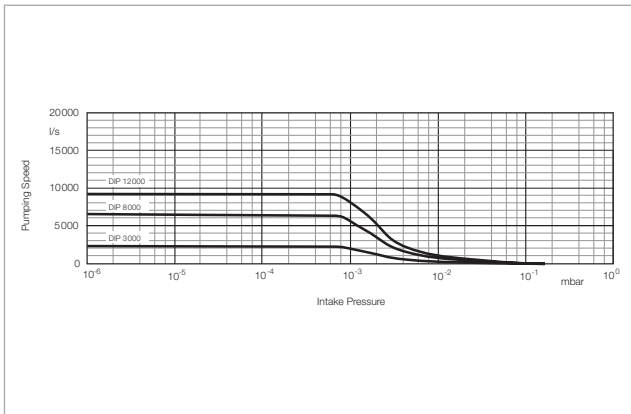

Pumping speed characteristics of the DIP 3000 to 12000 pumps as a function of intake pressure

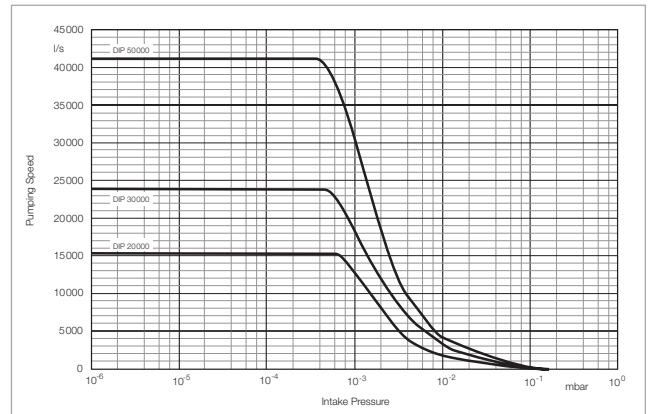

Pumping speed characteristics of the DIP 20000 to 50000 pumps as a function of intake pressure

Technical Data

DIP 3 000

DIP 8 000

DIP 12 000

High vacuum / forevacuum connection	DN	250 ISO-K / 63 ISO-K	400 ISO-K / 63 ISO-K	500 ISO-K / 100 ISO-K
Pumping speed for air ¹⁾ below 1×10^{-4} mbar	$l \times s^{-1}$	3 000	8 000	12 000
Operating range	mbar (Torr)	$< 10^{-2}$ to 10^{-7} (0.75×10^{-2} to 0.75×10^{-7})	$< 10^{-2}$ to 10^{-7} (0.75×10^{-2} to 0.75×10^{-7})	$< 10^{-2}$ to 10^{-7} (0.75×10^{-2} to 0.75×10^{-7})
Ultimate total pressure ¹⁾	mbar (Torr)	$< 5.0 \times 10^{-7}$ (3.75×10^{-7})	$< 5.0 \times 10^{-7}$ (3.75×10^{-7})	$< 5.0 \times 10^{-7}$ (3.75×10^{-7})
Max. permissible forevacuum pressure	mbar (Torr)	6.0×10^{-2} (4.5×10^{-2})	6.0×10^{-2} (4.5×10^{-2})	6.0×10^{-2} (4.5×10^{-2})
Pump fluid filling, min. / max.	l (qts)	1.0 / 1.4 (1.1 / 1.5)	1.7 / 3.4 (1.8 / 3.6)	2.4 / 5.3 (2.5 / 5.6)
Mains connection				
Standard EURO, 50/60 Hz	V	230 ~ 1 Ph	400 ~ 3 Ph Y	400 ~ 3 Ph Y
Standard Americas, 50/60 Hz	V	230 ~ 1 Ph	460 ~ 3 Ph Y	460 ~ 3 Ph Y
Special, 50/60 Hz	V	-	230 ~ 3 Ph Δ	230 ~ 3 Ph Δ
Heating power	kW	2.4	4.8	7.2
Number of heating cartridges		2	6	9
Heating up time	min	< 25	< 25	< 25
Cooling water (minimum) for pump ²⁾	$l \times h^{-1}$ (gal/min)	160 (0.7)	290 (1.28)	500 (2.2)
for cold cap baffle	$l \times h^{-1}$ (gal/min)	20 (0.09)	30 (0.13)	50 (0.22)
max. supply pressure	bar (psig)	6 (87)	6 (87)	6 (87)
Number of cooling circuits (including cold cap baffle)		2	2	2
Cooling water connection for pump	G (BPS)	3/8"	1/2"	1/2"
for cold cap baffle	G (BPS)	1/4"	3/8"	3/8"
Weight, approx.	kg (lbs)	29 (64)	70 (154)	102 (225)
Recommended backing pump ³⁾ at operating pressures > 10^{-4} mbar (> 0.75×10^{-4} Torr)		TRIVAC D 65 B + W 251	SV 300 + W 251	SV 300 + W 501
at operating pressures < 10^{-4} mbar (< 0.75×10^{-4} Torr)		-	TRIVAC D 65 B + W 251	TRIVAC D 65 B + W 251

Ordering Information

DIP 3 000

DIP 8 000

DIP 12 000

	Part No.	Part No.	Part No.
Oil diffusion pump			
Standard EURO	222 10	222 20	222 25
Standard Americas	222 10	500 670	500 591
Special	-	500 649	22225V003
Astrotorus baffle	227 50	227 60	227 65
Water flow monitor	500006623	500006623	500006623
Over-temperature protection switch	122 84	122 84	122 84
Contact thermometer	218 81	218 81	218 81
Resistance thermometer Pt100 sensor	200 02 958	200 02 958	200 02 958
Pump fluid ⁴⁾	see Catalog Part "Oils / Greases / Lubricants LEYBONOL"		

¹⁾ Measured to DIN 28 427 with LEYBONOL LVO 500 as the pump fluid

²⁾ The required quantity of cooling water refers to $\Delta T = 10 \text{ °C}$ (50 °F). The discharge temperature should not exceed 30 °C (86 °F)

³⁾ Single- or two-stage rotary vane vacuum pump (TRIVAC; SOGEVAC) from our range of forevacuum pumps jointly with Roots vacuum pumps (RUVAC) in pump systems

⁴⁾ Oil must be purchased separately

Technical Data

DIP 20 000

DIP 30 000

DIP 50 000

High vacuum / forevacuum connection	DN	630 ISO-F / 100 ISO-K	800 ISO-F / 160 ISO-K	1000 ISO-F / 160 ISO-K
Pumping speed for air ¹⁾ below 1×10^{-4} mbar	$l \times s^{-1}$	20 000	30 000	50 000
Operating range	mbar (Torr)	$< 10^{-2}$ to 10^{-7} (0.75×10^{-2} to 0.75×10^{-7})	$< 10^{-2}$ to 10^{-7} (0.75×10^{-2} to 0.75×10^{-7})	$< 10^{-2}$ to 10^{-7} (0.75×10^{-2} to 0.75×10^{-7})
Ultimate total pressure ¹⁾	mbar (Torr)	$< 5.0 \times 10^{-7}$ (3.75×10^{-7})	$< 5.0 \times 10^{-7}$ (3.75×10^{-7})	$< 5.0 \times 10^{-7}$ (3.75×10^{-7})
Max. permissible forevacuum pressure	mbar (Torr)	6.0×10^{-2} (4.5×10^{-2})	6.0×10^{-2} (4.5×10^{-2})	6.0×10^{-2} (4.5×10^{-2})
Pump fluid filling, min. / max.	l (qts)	6.0 / 9.0 (6.3 / 9.5)	7.0 / 15.0 (7.4 / 15.9)	12.0 / 25.0 (12.7 / 26.4)
Mains connection				
Standard EURO, 50/60 Hz	V	400 ~ 3 Ph Y	400 ~ 3 Ph Y	400 ~ 3 Ph Y
Standard Americas, 50/60 Hz	V	460 ~ 3 Ph Y	460 ~ 3 Ph Y	460 ~ 3 Ph Y
Special, 50/60 Hz	V	230 ~ 3 Ph Δ	230 ~ 3 Ph Δ	230 ~ 3 Ph Δ
Reduced power consumption through power controller (saves up 30%)	kW	8.4	12.6	16.8
Heating power	kW	12	18	24
Number of heating cartridges		12	18	24
Heating up time	min	< 25	< 30	< 30
Cooling water (minimum)				
for pump ²⁾	$l \times h^{-1}$ (gal/min)	600 (2.6)	900 (4.0)	1500 (6.6)
for cold cap baffle	$l \times h^{-1}$ (gal/min)	60 (0.26)	80 (0.35)	150 (0.66)
max. supply pressure	bar (psig)	6 (87)	6 (87)	6 (87)
Number of cooling circuits (including cold cap baffle)		2	3	3
Cooling water connection				
for pump	G (BPS)	1/2"	1/2"	1/2"
for cold cap baffle	G (BPS)	3/8"	3/8"	3/8"
Weight, approx.	kg (lbs)	172 (379)	296 (653)	560 (1235)
Recommended backing pump ³⁾ at operating pressures > 10^{-4} mbar (> 0.75×10^{-4} Torr) at operating pressures < 10^{-4} mbar (< 0.75×10^{-4} Torr)		SV 200 + W 501 TRIVAC D 65 B + W 251	SV 300 + W 1001 SV 300 + W 251	SV 630 B + W 2001 SV 300 + W 501

Ordering Information

DIP 20 000

DIP 30 000

DIP 50 000

	Part No.	Part No.	Part No.
Oil diffusion pump			
Standard EURO with control unit	222 30V001	222 35V001	222 40V001
Standard Americas with control unit	222 30V002	222 35V002	222 40V002
Standard EURO	222 30	222 35	222 40
Standard Americas	500 882	500 665	500 728
Special	22230V004	22235V006	500 654
Retrofit kit energy control unit	503 647V001	503 648V001	503 648V001
Retrofit kit energy control unit US	503 647V002	503 648V002	503 648V002
Astrotorus baffle	227 70	227 75	227 80
Water flow monitor	500006623	500006623	500006623
Over-temperature protection switch	122 84	122 84	122 84
Contact thermometer	218 81	218 81	218 81
Resistance thermometer Pt100 sensor	200 02 958	200 02 958	200 02 958
Pump fluid ⁴⁾	see Catalog Part "Oils / Greases / Lubricants LEYBONOL"		

¹⁾ Measured to DIN 28 427 with LEYBONOL LVO 500 as the pump fluid

²⁾ The required quantity of cooling water refers to $\Delta T = 10 \text{ °C}$ (50 °F). The discharge temperature should not exceed 30 °C (86 °F)

³⁾ Single- or two-stage rotary vane vacuum pump (TRIVAC; SOGEVAC) from our range of forevacuum pumps jointly with Roots vacuum pumps (RUVAC) in pump systems

⁴⁾ Oil must be purchased separately

LEYBOJET 630

Water-Cooled



LEYBOJET 630

The oil diffusion pumps from Leybold are well proven in industrial high vacuum applications.

They excel through their excellent vacuum performance data and owing to their rugged design are a reliable component in many medium and high vacuum systems.

The water-cooled LEYBOJET 630 was developed especially with the medium vacuum in mind.

Advantages for the User

- High and stable pumping speed well into medium vacuum range
- Low ultimate pressure
- Low oil backstreaming due to integrated water-cooled cold cap baffle
- High forevacuum tolerance
- Each heating cartridge is protected by a separate circuit breaker
- In maintaining the well proven heating system - heating insert with thermally conducting panels and heating cartridges - the LEYBOJET 630 is now equipped with an additional ejector nozzle for the purpose of obtaining a stable pumping speed well into the medium vacuum range

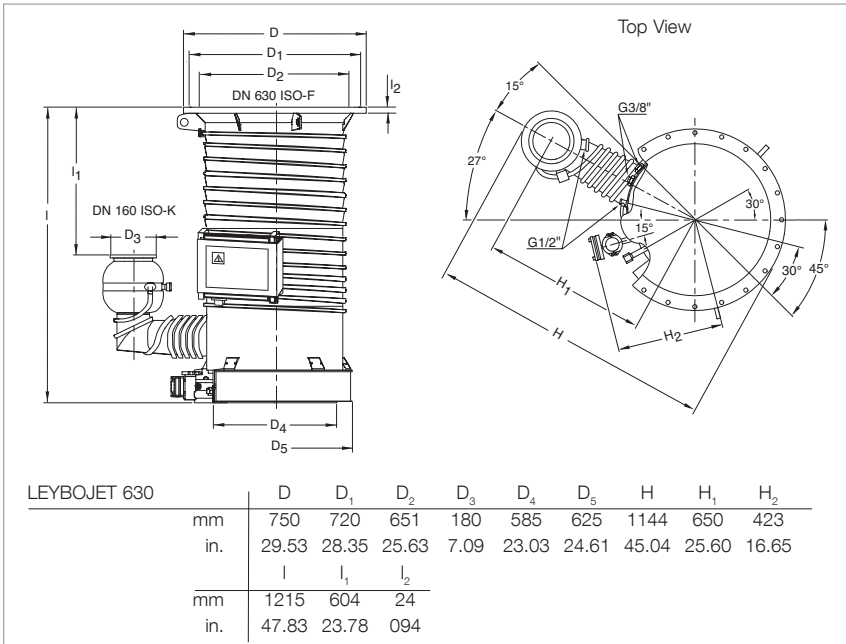

Dimensional drawing for the LEYBOJET 630

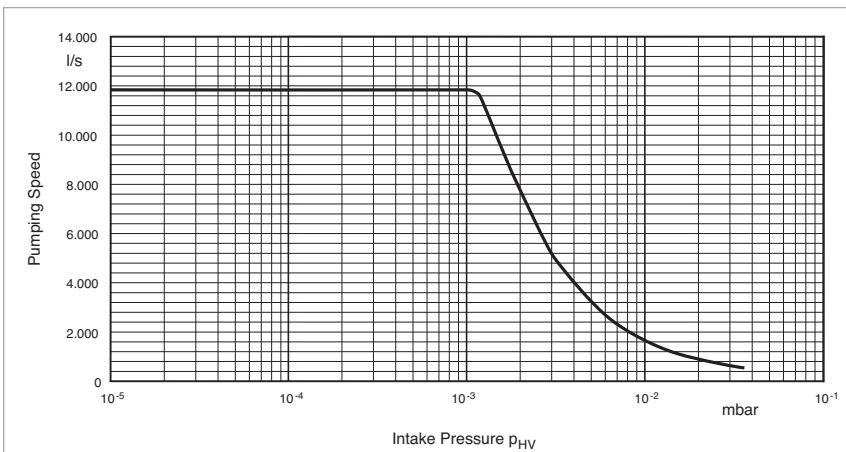

Pumping speed curve of the LEYBOJET 630 as a function of the intake pressure

Typical Applications

The principal areas of application of the LEYBOJET 630 are modern sputtering processes as well as vacuum melting and drying plants.

Supplied Equipment

The LEYBOJET 630 are supplied ready for connection but without the filling of pump fluid.

The inside of the pump is cleaned before delivery to such an extent that it is free of oil. The inside is evacuated. High and forevacuum flanges are equipped with gaskets, centering rings, shipping flanges, and clamping components.

Technical Data

LEYBOJET 630

High vacuum connection	DN	630 ISO-F
Forevacuum connection	DN	160 ISO-K
Pumping speed for air ¹⁾		
at 1 x 10 ⁻² mbar	l x s ⁻¹	1 700
at 1 x 10 ⁻³ mbar	l x s ⁻¹	12 000
< 1 x 10 ⁻⁴ mbar	l x s ⁻¹	12 000
Operating range	mbar (Torr)	< 10 ⁻² (< 0.75 x 10 ⁻²)
Ultimate total pressure ¹⁾	mbar (Torr)	< 5 x 10 ⁻⁷ (< 3.75 x 10 ⁻⁷)
Max. permissible forevacuum pressure	mbar (Torr)	6 x 10 ⁻¹ (4.5 x 10 ⁻¹)
Pump fluid filling, min. / max.	l (qts)	5.0 / 8.0 (5.3 / 8.5)
Mains connection 50/60 Hz	V	400, 3 Ph
Heating power	kW	10.8
Number of heating cartridges		9
Heating up time	min	< 30
Cooling water		
min. throughput ²⁾	l x h ⁻¹ (gal/min)	500 (2.2)
connection	G	1/2"
Number of cooling circuits (including cold cap baffle)		2
Cooling water connection		
for pump	G (BPS)	1/2"
for cold cap baffle	G (BPS)	3/8"
Weight, approx.	kg (lbs)	145 (320)
Recommended backing pump ³⁾		
at operating pressures		
> 10 ⁻⁴ mbar (> 0.75 x 10 ⁻⁴ Torr)		SV 200 + W 501
at operating pressures		
< 10 ⁻⁴ mbar (< 0.75 x 10 ⁻⁴ Torr)		TRIVAC D 65 B + W 251

Ordering Information

LEYBOJET 630

	Part No.
Oil diffusion pump LEYBOJET 630	502 180
Astrotorus baffle	227 70
Water flow monitor	500006623
Over-temperature protection switch	122 84
Contact thermometer	218 81
Resistance thermometer Pt100 sensor	200 02 958
Pump fluid ⁴⁾	see Catalog Part "Oils / Greases / Lubricants LEYBONOL"

¹⁾ Measured to DIN 28 427 with LEYBONOL LVO 500 as the pump fluid

²⁾ The required quantity of cooling water refers to $\Delta T = 10\text{ °C}$ (50 °F). The discharge temperature should not exceed 30 °C (86 °F)

³⁾ Single- or two-stage rotary vane vacuum pump (TRIVAC; SOGEVAC) from our range of forevacuum pumps jointly with Roots vacuum pumps (RUVAC) in pump systems

⁴⁾ Oil must be purchased separately

Oil Booster OB 6000 to OB 18000

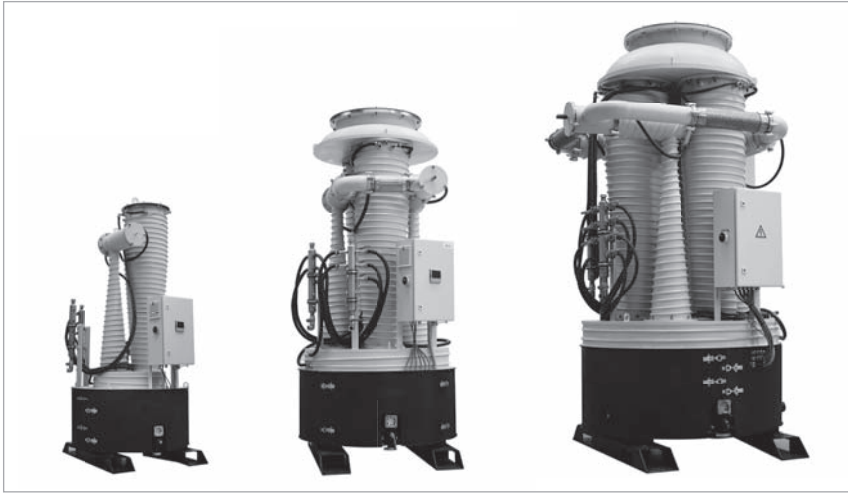

Oil Booster OB 6000 (left), OB 12000 (middle) and OB 18000 (right)

The design of the oil booster pumps from Leybold is well proven in industrial high vacuum applications. They excel above all through excellent vacuum performance data and are, owing to their rugged design a reliable component in many medium and high vacuum units.

The water cooled oil booster pump was developed in particular for applications in the rough and medium vacuum range. The pumps from the OB line from Leybold deliver when properly deployed, a maximum pumping speed at high gas throughputs.

Advantages for the User

- Very high pumping speed from a small sized pump
- Pump sizes 6000, 12,000 and 18,000 m³ per hour
- Simple to operate
- Rugged and long life
- Selectable flange connections (OB 12,000 and 18,000 only)
- Small manageable amount of spare parts
- Pump components (e.g. heating elements, diffusion corpus, jet corpus) are similar for all OB sizes and can be exchanged easily
- Modern electronic pump monitoring (PLC controlled)
- High efficiency due to direct heating
- Optimized heating design for long oil change intervals

Typical Applications

- Vacuum Induction Melting (VIM) or Vacuum Induction Degassing (VID) of special alloys are utmost important process steps in the metallurgy.
- Depending on the required steel-quality, the required process pressure in such applications is particularly low.
- Secondary metallurgy processes are becoming more popular thanks to the greater demand for better steels e.g. in the automotive, construction and rail markets.

Supplied Equipment

The OB pumps are plug-and-play but are delivered without pump fluid. The pump chamber is free of oil and has been cleaned. The inside volume is evacuated. The high vacuum and forevacuum flanges are equipped with sealing and centering rings as well as shipping flanges. Moreover, the electric circuit breaker box and the cooling water manifold have been installed for immediate connection. The included Pt100 temperature sensor ensures safe oil temperature monitoring. The installed overtemperature protection switch monitors and ensures safe operation of the pump.

Technical Data

Oil Booster

		OB 6000	OB 12000	OB 18000
Pumping speed for air below 1.0×10^{-3} mbar (7.5×10^{-3} Torr)	mbar x l x s ⁻¹	6.000	12.000	18.000
High vacuum connection standard	DN	400 ISO-K	630 ISO-F	630 ISO-F
optional	DN	400 ISO-K / ASA 16 / ASA 18	500 ISO-K / 800 ISO-F / ASA 16 / ASA 20	800 ISO-F / 1000 ISO-F / ASA 32 / ASA 35
Fore vacuum connection (standard)	DN	160 ISO-K	160 ISO-K	160 ISO-K
Operating range	mbar (Torr)	1 to 10^{-6} (0.75 to 10^{-6})	1 to 10^{-6} (0.75 to 10^{-6})	1 to 10^{-6} (0.75 to 10^{-6})
Ultimate total pressure	mbar (Torr)	5×10^{-6} (< 3.75×10^{-6})	5×10^{-6} (< 3.75×10^{-6})	5×10^{-6} (< 3.75×10^{-6})
Pump fluid filling	l (qts)	45 (47.6)	60 (63.4)	90 (95.1)
Mains connection				
Standard EURO, 50/60 Hz	V	400 ~ 3 Ph Y	400 ~ 3 Ph Y	400 ~ 3 Ph Y
Standard Americas, 50/60 Hz	V	460 ~ 3 Ph Y	460 ~ 3 Ph Y	460 ~ 3 Ph Y
Special, 50/60 Hz	V	230 ~ 3 Ph Δ	230 ~ 3 Ph Δ	230 ~ 3 Ph Δ
Weight	kg (lbs)	450 (992)	850 (1874)	1400 (3086)
Cooling water consumption	l x h ⁻¹ (gal/min)	700 (3.1)	800 (3.5)	1360 (6.0)
connection	G	1"	1"	1"

Ordering Information

Oil Booster

	OB 6000	OB 12000	OB 18000
	Part No.	Part No.	Part No.
Oil diffusion pump			
Standard EURO	503750V001	503654V001	503508V001
Standard US	503750V006	503654V006	503508V006
with control unit			
EURO version	503750V002	503654V002	503508V002
US version	503750V005	503654V005	503508V005
with control unit and waterflow/ -temperature monitoring			
EURO version (400 V)	503750V003	503654V003	503508V003
US version (460 V)	503750V004	503654V004	503508V004
Pump fluid	see Catalog Part "Oils / Greases / Lubricants LEYBONOL"		

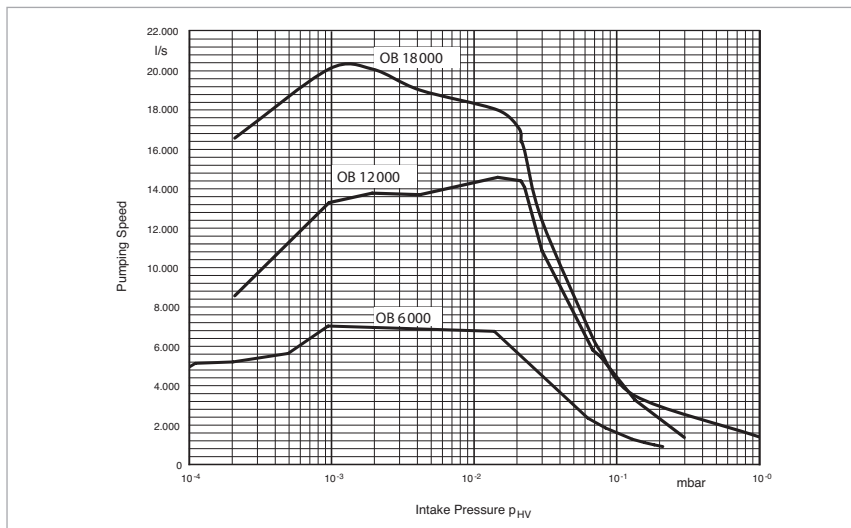

Pumping speed curves of the Oil Booster OB 6000 to OB 18000 as a function of the intake pressure

Accessories for Oil Diffusion Pumps

Astrotorus Baffles

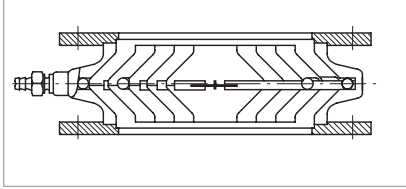

Section through an astrotorus baffle

The cooling inserts of the astrotorus baffles are made of copper, whereas the housing and the connection flange are made of standard steel.

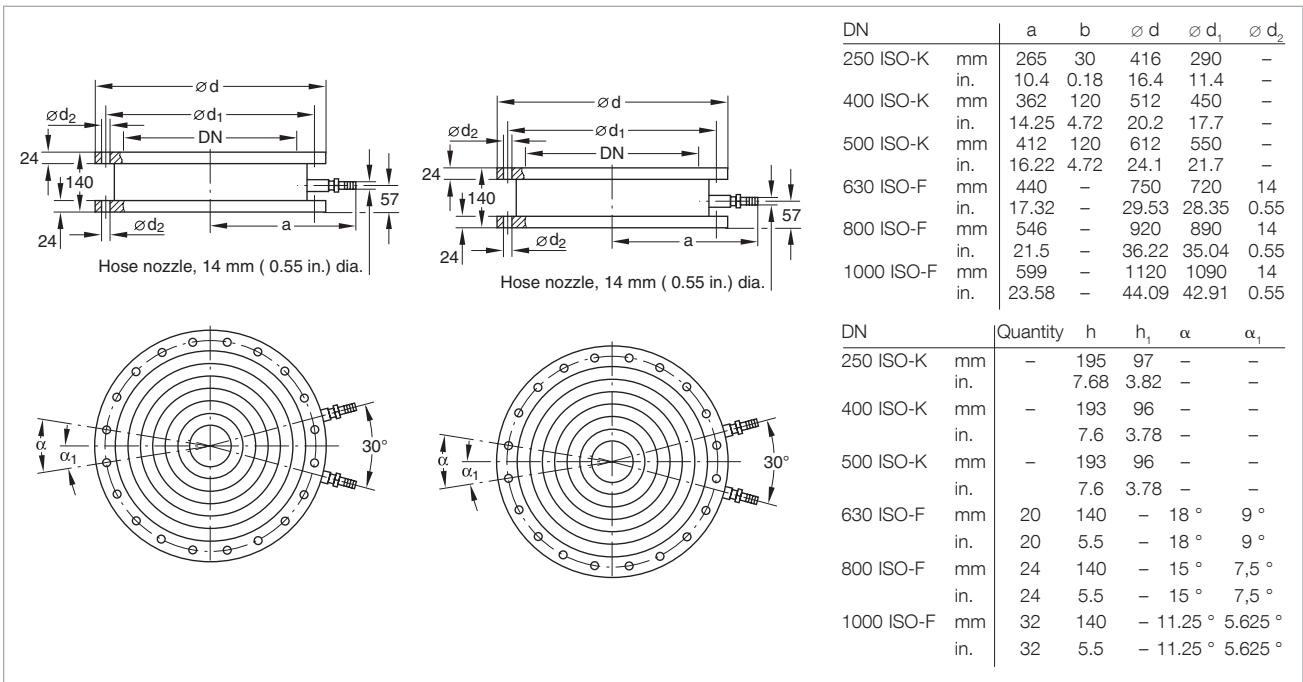

Dimensional drawing for the astrotorus baffle ISO-K (left) and ISO-F (right)

Technical Data

Astrotorus Baffles

Connection to pump	DIP	3 000	8 000	12 000
HV connection flanges	DN	250 ISO-K	400 ISO-K	500 ISO-K
Throttling of the pumping speed, approx.	%	30	30	30
Conductance	$l \times s^{-1}$	3 000	9 000	12 000
Weight	kg (lbs)	25.0 (55.2)	30.0 (66.2)	65.0 (143.5)

Ordering Information

Astrotorus Baffles

	Part No.	Part No.	Part No.
Astrotorus baffle			
250 ISO-K	227 50	-	-
400 ISO-K	-	227 60	-
500 ISO-K	-	-	227 65

Technical Data

Astrotorus Baffles

Connection to pump	DIP	20 000	30 000	50 000
HV connection flanges	DN	630 ISO-F	800 ISO-F	1000 ISO-F
Throttling of the pumping speed, approx.	%	30	30	30
Conductance	$l \times s^{-1}$	18 000	28 000	50 000
Weight	kg (lbs)	120.0 (264.9)	170.0 (375.3)	190.0 (419.4)

Ordering Information

Astrotorus Baffles

	Part No.	Part No.	Part No.
Astrotorus baffle			
630 ISO-F	227 70	-	-
800 ISO-F	-	227 75	-
1000 ISO-F	-	-	227 80

For matching valves, please ask us for a quotation.

Temperature dependant Switching Components for Automatic Pump System Control

The operational status of the diffusion pump depends on the temperature of the pump fluid in the pump boiler. Through temperature dependent switching components which are inserted into the pump boiler it is possible to monitor the operational status of the diffusion pump and signal its status to a process controller.

For this, the diffusion pump requires two thresholds. Depending on the type of pump, the upper threshold should be between 180 and 200 °C (356 and 392 °F) and the lower threshold between 90 and 100 °C (194 and 212 °F).

The upper threshold indicates that the diffusion pump is ready for operation and thus actuates certain devices, for example opening of the high vacuum valve ahead of the diffusion pump.

The lower threshold indicates that the diffusion pump has cooled down to such an extent that the backing pump and the cooling water supply may be switched off.

Over-temperature protection switches are used to monitor the temperature of the cooling water in the cooling water circuit of the diffusion pumps. When the temperature rises to unacceptably high levels (for example when the cooling water supply fails) the heater in the diffusion pump is switched off (correct electrical connection to the main supply is required). The use of over-temperature protection switches avoids unnecessary alarms that may be triggered by contaminated water when only a water flow monitor is used. The over-temperature protection switch is screwed on to a contact plate which is soldered to the cooling pipe on the

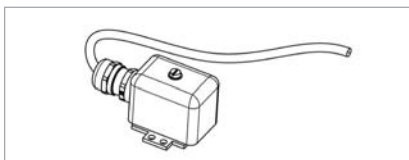

Over-temperature protection switch

pump's body.

Max. switching current: 5 A (230 V, 50/60 Hz).

Contact thermometer with a range from 0 to 400 °C (32 to 752 °F).

Through a trailing pointer two switching thresholds may be set up independently. The current oil temperature and the thresholds which have been set up can be read off at the

location of the diffusion pump. The contacting thermometer is not suited for remote signaling of temperatures.

Resistance thermometer Pt100 sensor. The measurement range of this sensor depends on the temperature display unit used by the customer where also the required thresholds are set up. The Pt100 sensor is ideal for remote signaling of temperatures.

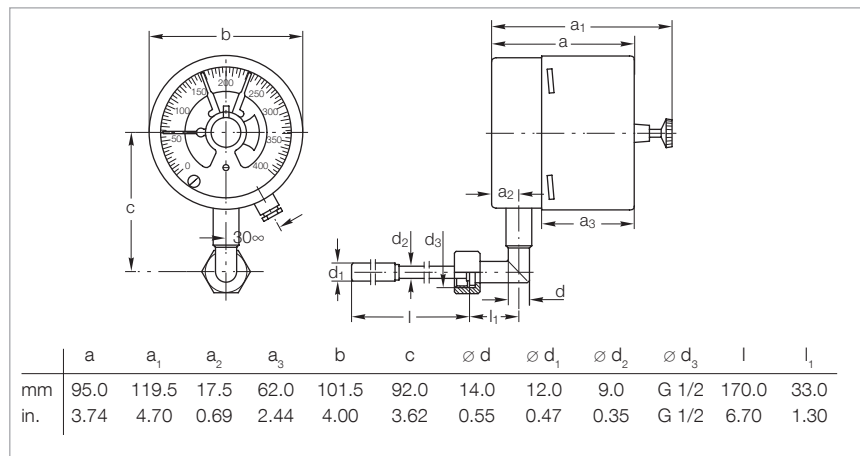

Dimensional drawing for the contact thermometer

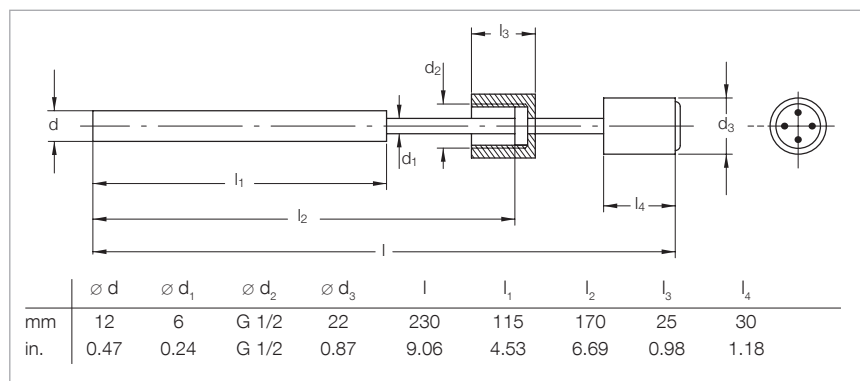

Dimensional drawing for the resistance thermometer Pt100 sensor

Ordering Information

Monitoring Instruments

	Part No.
Over-temperature protection switch	122 84
Contact thermometer (Measurement range 0 to +400 °C (+32 to +752 °F), Rating at 220 V AC: 250 mA [resistive load], Weight: 1.7 kg (3.7 lbs))	218 81
Resistance thermometer Pt100 sensor	200 02 958

Monitoring Instruments

Protection against Overheating

Water flow monitors are installed in the cooling water return section of the diffusion pump. When the cooling water throughput drops below a certain level, either the heater in the diffusion pump is switched off or a warning light or signal is triggered, depending of the type of circuit.

Measurement range: 1 to 40 l · h⁻¹
(0.06 to 2.52 gal/min)

The water throughput may be set within the limits stated with a high degree of reproducibility.

Water flow monitors may be installed in any orientation.

Max. switching capacity:
100 VA (230 V, 50/60 Hz).

Protection against Power Failure

A SECUVAC valve (see Product Section "Vacuum Valves") must be installed in the forevacuum line in order to prevent damage to the diffusion pump or the pump fluid in the event of a power failure affecting backing pumps which are not equipped with an automatic isolation valve. Rotary vane vacuum pumps from the TRIVAC B series are equipped with an automatic Pressure relief valve (intake isolation valve) as standard.

Protection against Pressure Increases in the Forevacuum Line

For protection against a pressure increase in the forevacuum line which is not caused by a power failure you may use our vacuum gauges which offer an adjustable switching threshold (see Product Section "Vacuum measuring - controlling").

Ordering Information

Water Flow Monitor

	Part No.
Water flow monitor	500006623

Power Controller



Power controller with integrated USB interface



Ethernet interface for PLC data integration

When it comes to the aspect of economic and efficient operation of diffusion pumps, power consumption plays an important role.

Through our DIP power controller, you may now drastically cut your power consumption - and this without impairing pump performance in any way!

Leybold Solutions provides a unique energy control unit with less thermal loss to control the heating power to save energy significantly!

Advantages to the User

- Energy saving up to 30% (low costs and ROI in less than three years)
- Further potential savings through temperature decrease in standby-mode
- High quality regulation with customized software
- Increased operation safety and comfort
- Improved service life for oil and heating cartridges
- Easy and exact to operate via PLC or manual directly at the pump
- Uncomplicated integration of generated data into your own process control or export data via USB port
- Strategically process analysis and optimization by interpretation of energy control unit data

Technical Data

Power Controller for

		DIP 20 000	DIP 30 000	DIP 50 000
Pumping speed for air below 1×10^{-4} mbar	$l \times s^{-1}$	20 000	30 000	50 000
Installed heating power	kW	12	18	24
Number of heating cartridges		2	6	9
Heating up time	min	< 25	< 30	< 30
Cooling water (minimum) for the pump	$l \times h^{-1}$	600	900	1500
for the cold cap baffle	$l \times h^{-1}$	80	80	150

Ordering Information

Power Controller for

	DIP 20 000	DIP 30 000	DIP 50 000
	Part No.	Part No.	Part No.
Oil diffusion pump with power controller			
DIP 20 000	22230V001	-	-
DIP 30 000	-	22235V001	-
DIP 50 000	-	-	22240V001
Retrofit kit (DIP power controller)			
DIP 20 000	503647V001	-	-
DIP 30 000	-	503648V001	-
DIP 50 000	-	-	503649V001
Full-service retrofit kit ¹⁾			
DIP 20 000	AS8100F	-	-
DIP 30 000	-	AS8101F	-
DIP 50 000	-	-	AS8102F
Mineral oil LVO 500			
1 l	L50001	L50001	L50001
5 l	L50005	L50005	L50005
20 l	L50020	L50020	L50020
Mineral oil LVO 510			
1 l	L51001	L51001	L51001
5 l	L51005	L51005	L51005
Silicone oil LVO 520			
1 l	L52001	L52001	L52001
5 l	L52005	L52005	L52005
Silicone oil LVO 530			
1 l	L53001	L53001	L53001

¹⁾ Delivery, installation, commissioning and instruction of the staff is included

Adsorption Traps with Aluminium Oxide Insert

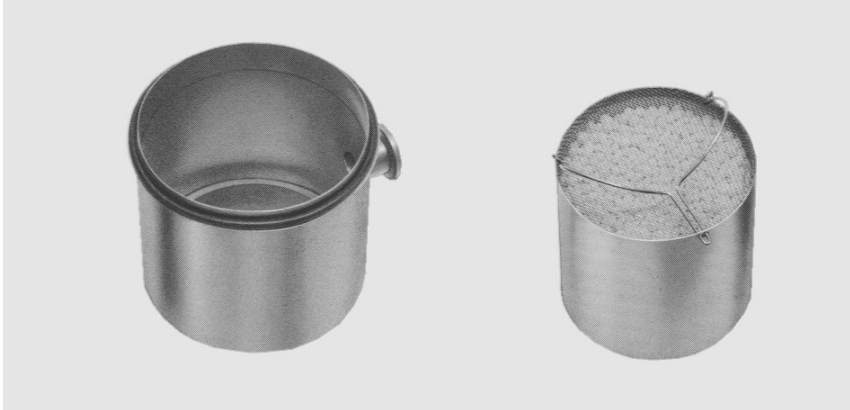

Adsorption traps are installed in all those cases where an oil-free vacuum is to be produced with oil-sealed vacuum pumps.

Advantages to the User

- Backstreaming of oil is reduced by 99%
- Long service life
- High conductance
- Filling can be easily exchanged
- Improvement in the ultimate pressure attained by backing pumps by one order of magnitude
- Stainless steel housing and insert
- NBR gasket

Typical Applications

- Product of an oil-free vacuum

Supplied Equipment

- Complete with insert
- Without adsorbent

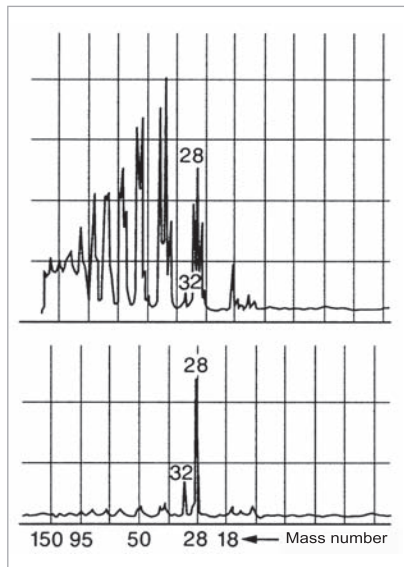

Residual gas spectrum; top ahead of a rotary vacuum pump, bottom ahead of a rotary vacuum pump with adsorption trap

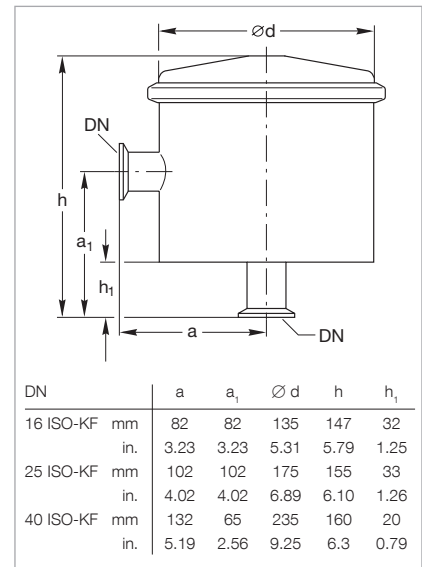

Dimensional drawing for the adsorption traps

Technical Data

		16 ISO-KF	25 ISO-KF	40 ISO-KF
Conductance at 10 ⁻² mbar (Torr)	I x s ⁻¹	4.0	6.0	12.0
Service live with Al oxide	Months	3	3	3
Al oxide filling	l (qts)	0.5 (0.53)	1.0 (1.06)	2.0 (2.1)
Weight, approx.	kg (lbs)	1.3 (2.9)	1.3 (2.9)	4.0 (8.8)

Adsorption Traps

Ordering Information

	16 ISO-KF	25 ISO-KF	40 ISO-KF
Adsorption trap	Part No. 854 14	Part No. 854 15	Part No. 854 16
Activated aluminum oxide in tin 1.6 l (approx. 1.2 kg (2.65 lbs))	854 10	854 10	854 10

Adsorption Traps

Applications and Accessories, Cryo Pumps

Application	Cryo pumps									
	COOLVAC 1500	COOLVAC 2000	COOLVAC 3000	COOLVAC 5000	COOLVAC 10000	COOLVAC 18000	COOLVAC 30000	COOLVAC 60000	COOLVAC 30000 LN ₂	COOLVAC 60000 LN ₂
General research	■	■	■	■	■	■	■	■	■	■
Evaporation coating systems	■	■	■	■	■	■	■	■		
Transfer chambers / Loadlock	■	■	■	■	■	■				
Metallization systems	■	■	■	■	■	■	■	■		
Sputtering systems	■	■	■	■	■					
Ion implanters	■	■	■	■						
Electron beam welding systems	■	■	■	■	■	■				
Space simulation chambers	■	■	■	■	■	■	■	■	■	■
UHV systems	■	■	■							
Beam tubes in particle accelerators	■	■								
Vacuum furnaces				■	■	■	■	■	■	■

Model versions

BasicLine Version without electronics, with temperature sensors	■	■	■	■	■	■	■	■		
iClassicLine version with electronics and integrated controller, with temperature sensors and electrical heaters	■	■	■	■	■	■	■	■		
BasicLine LN ₂ version with liquid nitrogen cooling, temperature sensors and electrical heaters and over-temperature protection									■	■

Accessories

Page

Purge gas option, on request		■	■	■	■	■				
Compressor unit COOLPAK 2000 Series		■	■	■						
Compressor unit COOLPAK 6000 Series		[■]	[■]	[■]	■	■	■	■	■	■
Flexible pressure lines		■	■	■	■	■	■	■	■	■
Gas manifold GD 2 for multiple operation of up to two cryo pumps		■	■	■	■*)	■*)				
Gas manifold GD 4 for multiple operation of up to four cryo pumps		■	■	■						
Low temperature measuring instrument MODEL 211 S (BasicLine Series only)		■	■	■	■	■	■	■	■	■

[■] = For dual and multiple operation only *) Multiple operation only after consultation with technical support

Applications and Accessories, Cryogenics

Cold heads	single-stage				double-stage	
	COOLPOWER 50	COOLPOWER 140 T	COOLPOWER 250 MD	COOLPOWER 7/25	COOLPOWER 5/100	COOLPOWER 10 MD
Application						
Cooling of samples, sensors and detectors	■	■	■	■	■	■
Cooling of detectors in astronomy	■	■	■	■	■	■
Cooling of samples for spectroscopy				■	■	■
Cooling of samples for applications in medical technology and R&D				■	■	■
Cooling of HTS superconductors	■	■	■	■	■	■
Cooling of LTS superconductors				(■)	(■)	(■)
Cooling in medical equipment	■	■	■	■	■	■
Cooling of surfaces for pumping of gases	■	■	■	■	■	■
Cryogenic process gas cleaning	■	■	■	■	■	■
Condensation, resublimation and freezing of gases	■	■	■	■	■	■

(■) = Only LTS superconductors with $T_c > 10$ K

Accessories

Page

Compressor unit COOLPAK 2000 Series		■			■		
Compressor unit COOLPAK 6000 Series		(■)	■	■	(■)	■	■
Low temperature measurement instrument MODEL 211S		■	■	■	■	■	■
Temperature sensor		■	■	■	■	■	■

(■) = Only high T_c superconductors

Conversion of Units

Kelvin (K), Celsius (°C), Fahrenheit (°F)

Calculation from	Calculation to	Formula
Celsius	Fahrenheit	$^{\circ}\text{F} = ^{\circ}\text{C} \times 1.8 + 32$
Celsius	Kelvin	$\text{K} = ^{\circ}\text{C} + 273.15$
Kelvin	Celsius	$^{\circ}\text{C} = \text{K} - 273.15$
Kelvin	Fahrenheit	$^{\circ}\text{F} = \text{K} \times 1.8 - 459.67$
Fahrenheit	Celsius	$^{\circ}\text{C} = (^{\circ}\text{F} - 32) / 1.8$
Fahrenheit	Kelvin	$\text{K} = (^{\circ}\text{F} + 459.67) / 1.8$

The following applies to absolute zero:
 $0 \text{ K} = -273.15 \text{ }^{\circ}\text{C} = -459.67 \text{ }^{\circ}\text{F}$.

Cryo Pumps

Cryo pumps are gas entrapment vacuum pumps for the pressure range from 10^{-3} to $\leq 10^{-11}$ mbar (0.75×10^{-3} to $\leq 0.75 \times 10^{-11}$ Torr). The principle of operation is that gaseous substances are bound to the cold surfaces within the pump by means of cryocondensation, cryosorption or cryotrapping.

In order to be able to produce a high or ultra-high vacuum, the cold surfaces (cryopanel) must be cooled to a sufficiently low temperature. Depending on the type of cooling system used a distinction is made between refrigerator cryo pumps, bath cryo pumps and evaporator cryo pumps.

Leybold manufactures refrigerator-cooled cryo pumps as well as liquid nitrogen supported cryo pumps.

Advantages to the User

Advantages offered by the pumping principle

- High effective pumping speed for all gases
- Extremely high pumping speed for H_2O (water) and H_2 (hydrogen)

For a given diameter of the high vacuum flange, the cryopump offers the highest pumping speed of all high vacuum pumps.

Advantages offered by Design

In contrast to gas transfer high vacuum pumps, cryo pumps do not have any mechanically moving, oil or grease lubricated parts on the vacuum side.

The following advantages are a direct result of this design characteristic:

- Hydrocarbon-free vacuum in the pressure range from 10^{-3} to $\leq 10^{-11}$ mbar (0.75×10^{-3} to $\leq 0.75 \times 10^{-11}$ Torr).
- Insensitivity to mechanical disturbances from particles coming from the process or external vibrations.

Further Advantages

- More compact than comparable pump systems offering a pumping speed of over 1500 l x s^{-1}
- Backing pump is only required during start-up and during regeneration
- User friendly process control and pump control
- Favorable price-performance ratio and low running costs especially at higher pumping speeds

The cryo pumps are cooled by the well-proven two-stage refrigerators from Leybold's COOLPOWER line (Gifford/McMahon principle).

The design of a refrigerator cryopump from the COOLVAC range is shown schematically in the figure below.

The first stage of the cold head (6) cools the thermal radiation shield (7) and the baffle (8) of the pump.

Both are made of copper with high thermal conductivity in order to optimally utilize the available refrigerating capacity.

Operating temperatures of 45 K to 80 K are reached depending on the type of pump and on the operating conditions. Mainly water but also carbon oxides are pumped here.

The second stage of the cold head (9) is used to cool the cryopanel (10). These pumping surfaces are also made of copper of high thermal conductivity and they are tightly linked thermally to the second stage of the cold head.

Depending on the operating conditions, operating temperatures of 10 to 20 K are attained.

Here the process of cryocondensation of N_2 (nitrogen), O_2 (oxygen) and Ar (argon) will take place.

The inner part of the pumping surfaces are additionally covered with activated charcoal. Here the process of adsorption (cryosorption) of H_2 (hydrogen), Ne (neon) and He (helium) will take place.

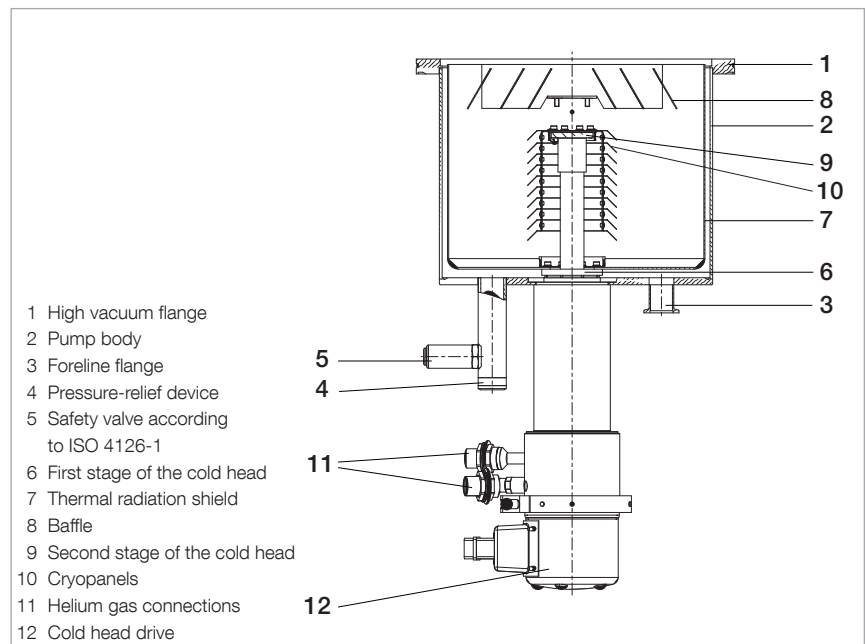

COOLVAC refrigerator cryopump

All cryo pumps from the COOLVAC range are equipped with all safety related components, particularly with a pressure-relief device and safety valve with flange hub **(4, 5)** which is equipped with an additional DN 40 KF flange for connection of an exhaust line.

The pump's body is made of high-quality stainless steel.

Helium compressors from the COOLPAK range are required for operating the COOLPOWER cold heads, which are incorporated within the COOLVAC range of cryo pumps.

Regenerating Cryo Pumps

An important aspect of the operation of cryo pumps is that of regeneration. Since a cryo pump is a gas entrapment pump, the pumped gases must be removed from the pump before the capacity limit is exceeded.

The so-called "regeneration" occurs by switching off the compressor unit and heating up the cold surfaces to room temperature. The pumped gases are pumped out by means of a roughing pump. As soon as the vacuum pressure is low enough, the cryo pump can be cooled down again. Finally, when the operating temperature has been reached, the regeneration process is complete.

Various procedures are available for regeneration as listed below:

- Heating up through self-heating after the refrigerator has been switched off, and subsequent re-cooling
- Heating up with the support of a dry, warm inert gas
- Heating up by means of an electrical heater on the cold surfaces.

These methods can be combined with each other.

iClassicLine Cryo pumps with regulated regeneration system

The cryo pumps from the *iClassicLine* (*iCL*) range are gradually heated up to room temperature by means of electrical heaters at both cold head stages. Pressure, temperature and heating power are monitored in detail within the cryo pumps.

During the process the pumped gases are released one after the other in the following sequence:

- Gases adsorbed at the cryopanel (e.g. hydrogen, helium, neon),
- Gases condensed at the cryopanel (e.g. nitrogen, oxygen, argon),
- Gases and vapors which have condensed on to the baffle and thermal radiation shield (e.g. water vapor).

The benefit of Leybold's regeneration process described above is that no additional purge gas is required during the regeneration of inert, unreactive gases.

Our application support team is on hand to answer any safety questions you may have in relation to client-specific process gases.

The accessories required for automatic regeneration, such as temperature sensors on both cold head stages, pressure gauge head, fore-vacuum valve and electrical controller are an integral part of the cryo pump in the *iClassicLine* range. Additional accessories can be supplied on request.

BasicLine cryo pumps with no regulated regeneration system

In the case of cryo pumps from the *BasicLine* (*BL*) range, regeneration takes place manually in two sub-steps:

- Switching off the refrigerator system and waiting until room temperature is reached. (The temperature can be read off by the customer from the built-in silicon diode).
- Re-cooling after a sufficiently low pressure is reached in the cryo pump.

Additional components such as temperature display unit, pressure gauge head and fore-vacuum valve are not part of the standard scope of delivery for *BasicLine* cryo pumps, although they are available as accessories on request. Leybold will be pleased to advise you on the optimum component configuration for your application.

The cryo pumps from both the *BasicLine* range as well as those from the *iClassicLine* range are available in suction capacity classes from 1500 l/s to 60000 l/s.

Multiple Operation of Refrigerator Cryo Pumps

The powerful Leybold compressor units COOLPAK 6000 H open up the possibility of operating up to three refrigerator cryo pumps simultaneously.

Advantages to the User

- Significantly reduced investment and operating costs
- Small footprint

Cold Heads

A refrigerator is a cooling machine which operates on the basis of a thermodynamic cycle (Carnot) to produce cryogenic temperatures ($T \leq 120$ K).

Refrigerators operating according to the Gifford/McMahon principle have succeeded over other methods of cooling cryo pumps and cryogenic applications. Exclusively such coolers are produced and used by Leybold.

The cold heads consist essentially of three modules:

- Drive module
- Displacement unit
- Cold head stage(s)

Helium compressors from the COOL-PAK range are used to drive the cold heads from the COOLPOWER range.

In addition to the standard products, Leybold also offers these cold heads, as well as cryo pumps, in custom designs in accordance with customer requirements.

Gifford/McMahon-Refrigerators

Advantages to the User

- No liquid helium and no liquid nitrogen are required
- Very simple to operate
- Easy process control and temperature control via a computer
- No space problems since cold head and compressor unit can be installed and operated apart
- Installation of the cold head basically in any orientation
- High reliability
- Long periods of operation without maintenance

Typical Applications

- Cooling of
 - cryopanel in cryo pumps thereby producing high or ultra-high vacuum
 - superconducting magnets; for instance in magnetic resonance tomography
 - samples for spectroscopic analysis in solid state and surface physics
 - high-temperature and low-temperature superconductors
 - semiconductors
 - infrared and gamma detectors
- Recondensation of liquids and cleaning of gases
- Calibration of sensors

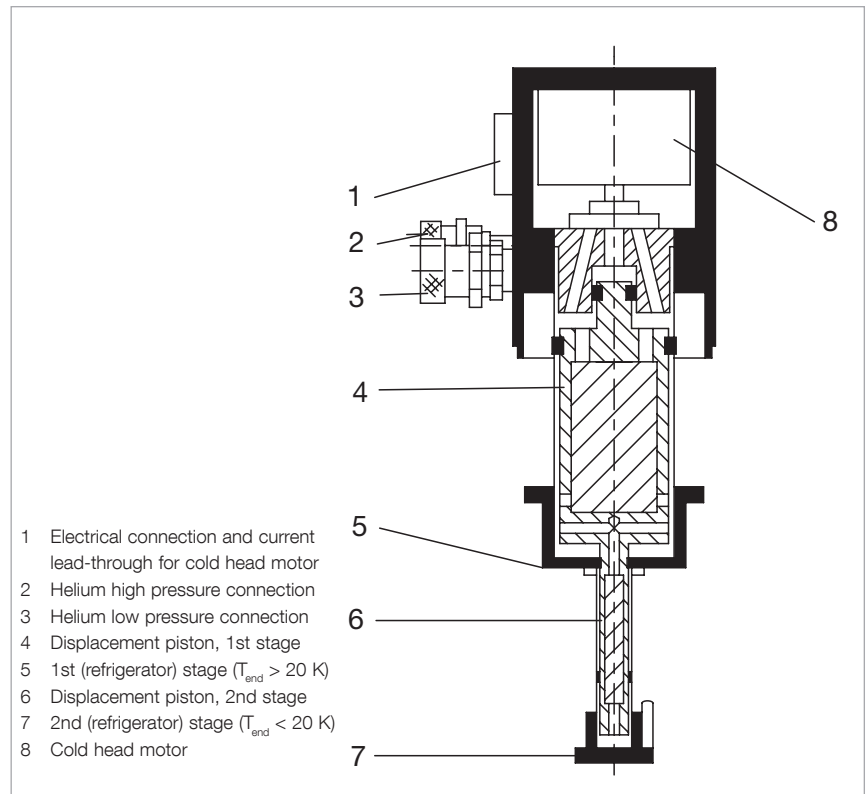

Dual-stage Gifford/McMahon cold head (schematic diagram)

Cold heads from the COOLPOWER range

The standard range of single-stage and double-stage cold heads matches a wide range of applications.

Leybold is offering refrigerators with usable refrigerating powers from 20 W to 250 W at 80 K (single-stage).

In two-stage systems, the refrigeration capacities of the second stage range in between 5 W and 20 W at 20 K.

Pneumatically driven cold heads

Advantages

- **Simple Design**
The pneumatic drive system for the displacer of these cold heads from Leybold consists of only two mechanically moving components: the rotating control valve and the synchronous motor driving the control valve.
- **Easy and quick maintenance**
Owing to the simple design of the built-in cold heads, maintenance is easy. Maintenance can be performed in place without detaching the cold head from the vacuum chamber.

Mechanically driven cold heads

Advantages through low vibrations

With these cold heads, movement of the displacer unit is automatically controlled via a crank drive, which leads to low vibration levels.

Here, too, maintenance at the place of use can be carried out without impacting the surrounding infrastructure, in particular with no breaking of the chamber's vacuum by the service personnel.

Advantages through high reliability

Leybold cold heads are used in applications which place particularly high demands on reliability, such as magnetic resonance imaging in medical technology, the cooling of low and high temperature superconductors, and the cooling of detectors in telescopes for astronomy.

Refrigeration capacity diagrams (see next page of the catalogue)

On the following page of the catalogue you will find the refrigeration capacity diagrams for our single-stage and double-stage COOLPOWER cold heads.

The interpretation of the diagrams for our double-stage cold heads is explained using the example of the refrigerator cold head COOLPOWER 5/100 (see diagram on next page). If applying heat loads of 100 W on the 1st stage and of 6 W on the 2nd stage, simultaneously, then the intersection point (●) 100 W/ 6 W of the two lines gives the expected 1st stage and 2nd stage temperature of 80 K and of 20 K, respectively.

Without thermal load (left lower intersection point (○) 0 W / 0 W of this "load map"), ultimate temperatures of < 30 K and of < 10 K will be reached on the 1st stage and on the 2nd stage, respectively.

Refrigerating Capacity of Cryogenic Cold Heads

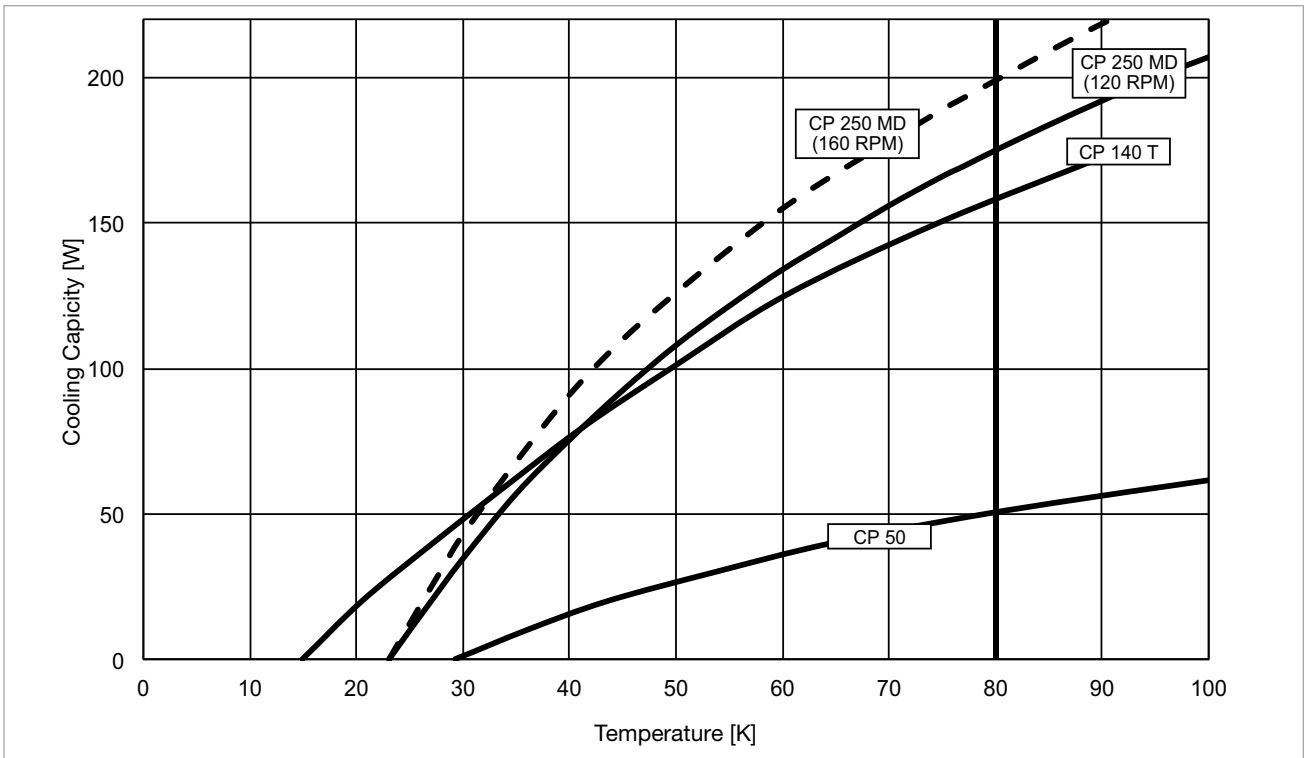

Typical refrigerating capacity of the single-stage cold heads COOLPOWER 50, COOLPOWER 140 T and COOLpower 250 MD

High Vacuum Pumps

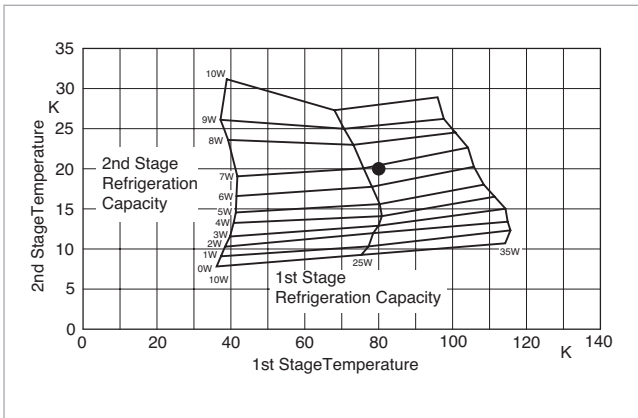

Typical refrigerating capacity of the cold head COOLPOWER 7/25

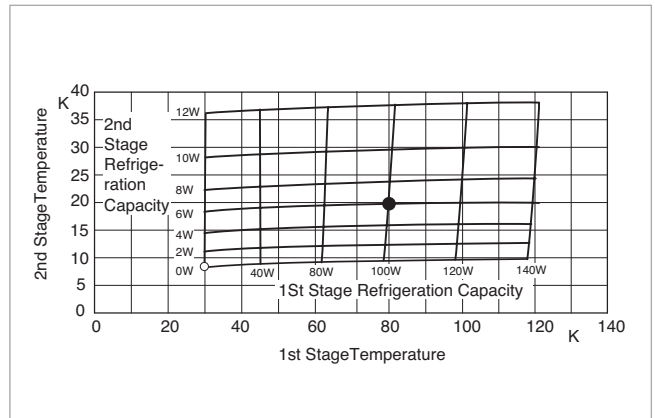

Typical refrigerating capacity of the cold head COOLPOWER 5/100

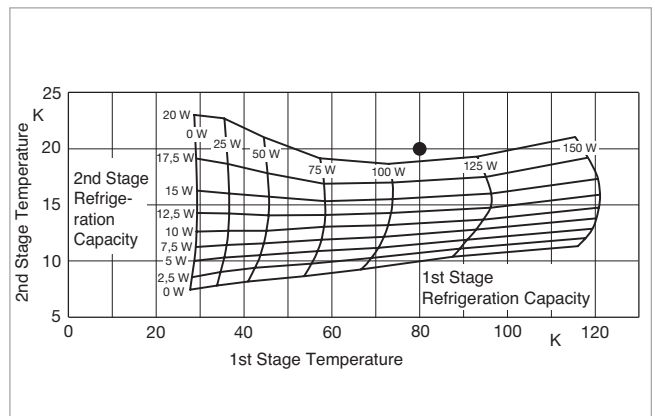

Typical refrigerating capacity of the cold head COOLPOWER 10 MD

The refrigerating capacities stated apply to vertical operation with the cold end at the bottom.

Compressor Units

COOLPAK 2000 and COOLPAK 6000 H compressors are available for single and multiple operation of the cold heads from the COOLPOWER line as well as for operation of cryo pumps from the COOLVAC line.

The compressors are characterised by high reliability and ease of maintenance. The maintenance interval is as long as 30,000 hours depending on the application. The low level of noise and vibration is achieved through the

exclusive use of scroll compressors and specially selected components.

The possibilities for single and multiple operation of refrigerator cryo pumps are given in the table below:

Compressor Unit	For the operation of	
	Cold Heads	Cryo Pumps
COOLPAK 2000/2200	1 x COOLPOWER 50 1 x COOLPOWER 7/25	1 x COOLVAC 1500/2000/3000
COOLPAK 6000 HD	2 x COOLPOWER 50 2 x COOLPOWER 7/25	2 x COOLVAC 1500 BL/2000 BL/3000 BL 2 x COOLVAC 5000 BL/ 10000 BL *)
COOLPAK 6000 H/6200 H	1 x COOLPOWER 140 T 1 x COOLPOWER 5/100	up to 3 x COOLVAC 1500 iCL /2000 iCL up to 2 x COOLVAC 3000 iCL up to 2 x COOLVAC 5000 iCL/10000 iCL *) 1 x COOLVAC 5000 BL/10000 BL
COOLPAK 6000 HMD/6200 HMD	1 x COOLPOWER 250 MD 1 x COOLPOWER 10 MD	1 x COOLVAC 30000 BL LN ₂ 1 x COOLVAC 60000 BL LN ₂

*) only after consulting with our technical support

Products Cryo Pumps

Cryo Pumps with fully Automatic Control, iClassicLine COOLVAC 1500 iCL



Advantages to the User

- Hydrocarbon-free high vacuum
- High capacity for argon and hydrogen
- High crossover value
- Simple operation
- Trouble-free integration into complex systems
- Fully automatic regeneration through Cryo Compact Control ¹⁾
- Easy servicing

Typical Applications

- Evaporators
- Sputtering systems
- Ion implanters
- Optical coating systems
- Metallization systems

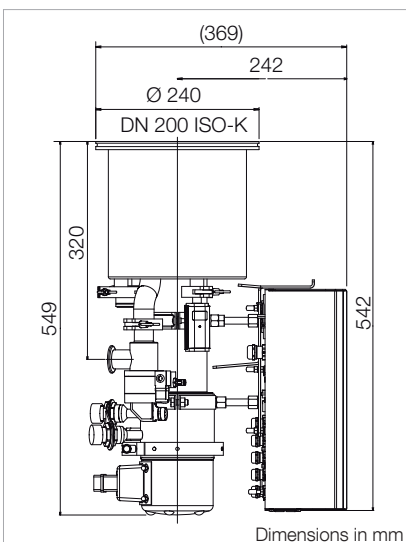

Dimensional drawing for the COOLVAC 1500 iCL (DN 200 ISO-K)

Technical Data

COOLVAC 1500 iCL

High vacuum (HV) flange	DN	200 ISO-K / 200 CF / 6" ANSI
Fore vacuum flange ²⁾	DN	25 ISO-KF
Flange for connection a gauge head ³⁾	DN	16 ISO-KF
Flange for the electrical connection	DN	16 ISO-KF
Pressure-relief device with flange connection for gas exhaust line	DN	40 ISO-KF
4-way current feedthrough for Si diode on a flange	DN	16 ISO-KF
Heaters		
1st stage	W	160
	V AC	42
2nd stage	W	90
	V AC	42
Temperature sensor		
1st stage		PT 100
2nd stage		Si-Diode
Built-in cold head	COOLPOWER	7/25
Weight	kg (lbs)	25 (55.1)
Cooldown time to T ₂ = 20 K	min	60
Crossover value	mbar x l (Torr x l)	210 (155)
Pumping speed		
H ₂ O	l x s ⁻¹	4600 ± 10%
Ar / N ₂	l x s ⁻¹	1200 / 1500 ± 10%
H ₂	l x s ⁻¹	2500 ± 10%
Capacity		
Ar / N ₂	bar x l	1000 / 1000
H ₂ at 10 ⁻⁶ mbar	bar x l	15 ⁴⁾
Max. throughput		
Ar / N ₂	mbar x l x s ⁻¹ (Torr x l x s ⁻¹)	12 (9) / 12 (9)
H ₂	mbar x l x s ⁻¹ (Torr x l x s ⁻¹)	6 (4.5) ⁴⁾
Helium connections	DN	1/2"
(Self-sealing couplings: outside thread, type 5400-S2-8)		

1) Accessories, necessary for automatic operations (i.e. electrical regeneration heaters, forevacuum valve DN 25 ISO-KF, and vacuum gauge DN 16 ISO-KF), are included with the scope of delivery and are connected to the integrated COOL.DRIVE.

2) Electropneumatic angle valve included.

3) Vacuum gauge head included.

4) The maximum throughput values given for hydrogen (H₂) are true for regenerated cryo pumps under short-term loads only. For continuous operations, both throughput and capacity values will be lower.

Ordering Information

COOLVAC 1500 iCL

	Single Operation		Dual operation		Multiple operation	
	Europe	USA/Japan	High Voltage	Low Voltage	High Voltage	Low Voltage
	Part No.		Part No.		Part No.	
COOLVAC 1500 iCL						
DN 200 CF	844201V0002		844201V0002 (2x)		844201V0002 (3x)	
DN 6" ANSI	844201V0004		844201V0004 (2x)		844201V0004 (3x)	
DN 200 ISO-K	844201V0006		844201V0006 (2x)		844201V0006 (3x)	

Compressors, flexlines and cables

Compressor						
CP 2000	840000V2000	-	-	-	-	-
CP 2200	-	840000V2200	-	-	-	-
CP 6000 H	-	-	840000V6001	-	840000V6001	-
CP 6200 H	-	-	-	840000V6201	-	840000V6201
Power supply cable for compressor	-		see Ordering Information of the compressor units			
Set of flexlines						
FL 4.5 (1/2", 1/2")	892 87		892 87 (2x)		892 87 (3x)	
or FL 9.0 (1/2", 1/2")	892 88		892 88 (2x)		892 88 (3x)	
or FL 18.0 HP (1/2") + FL 18.0 LP (1/2")	840203 + 840204		840203 (2x) + 840204 (2 x)		840203 (3x) + 840204 (3 x)	
Gas manifold (1 piece each)						
GD 2	-		840 253 (2x)		-	
GD 4	-		-		840 254 (2x)	
Compressor unit control cable ¹⁾						
COOLPAK control cable, 5 m (16.4 ft)	844231V4005		844231V4005 (2x)		844231V4005 (3x)	
or COOLPAK control cable, 10 m (32.81 ft)	844231V4010		844231V4010 (2x)		844231V4010 (3x)	
or COOLPAK control cable, 20 m (65.62 ft)	844231V4020		844231V4020 (2x)		844231V4020 (3x)	
COOLPAK adapter for multi control	-		844231V5003		844231V5003	

Optional electronics, cables and equipment

CRYOVISION control and display unit	844231V0002		844231V0002		844231V0002	
CRYOVISION control cables						
CRYOVISION control cable, 5 m (16.4 ft)	844231V2005		844231V2005		844231V2005	
or CRYOVISION control cable, 10 m (32.81 ft)	844231V2010		844231V2010		844231V2010	
or CRYOVISION control cable, 20 m (65.62 ft)	844231V2020		844231V2020		844231V2020	
Network control cable for the link between the pumps						
CRYOVISION / Network control cable, 5 m (16.4 ft)	-		844231V2005		844231V2005 (2x)	
or CRYOVISION / Network control cable, 10 m (32.81 ft)	-		844231V2010		844231V2010 (2x)	
or CRYOVISION / Network control cable, 20 m (65.62 ft)	-		844231V2020		844231V2020 (2x)	

Optional interface module

COOLVAC ProfiBus module ProfiBus - RS232 Converter for COOL.DRIVE and CRYOVISION either COOLVAC ProfiBus module connected to COOL.DRIVE control and monitoring unit of each cryo pump (in this case CRYOVISION and network control not to apply)	844000V1		844000V1 (2x)		844000V1 (3x)	
or COOLVAC ProfiBus module connected to CRYOVISION ²⁾	844000V1		844000V1		844000V1	

The arrangement of the components is shown in the chapter "Accessories" under the heading "iCOOLVAC iClassicLine, System Components".

1) The length of the control cable should match to the length of the flexlines.

2) At multiple operation with reduced communication speed to single cryo pumps.

COOLVAC 2000 iCL



Advantages to the User

- Hydrocarbon-free high vacuum
- High capacity for argon and hydrogen
- High crossover value
- Simple operation
- Trouble-free integration into complex systems
- Fully automatic regeneration through integrated COOL.DRIVE controller ¹⁾
- Easy on-site servicing without pump disassembling and reconditioning of the vacuum system possible

Typical Applications

- Evaporators
- Sputtering systems
- Ion implanters
- Optical coating systems
- Metallization systems

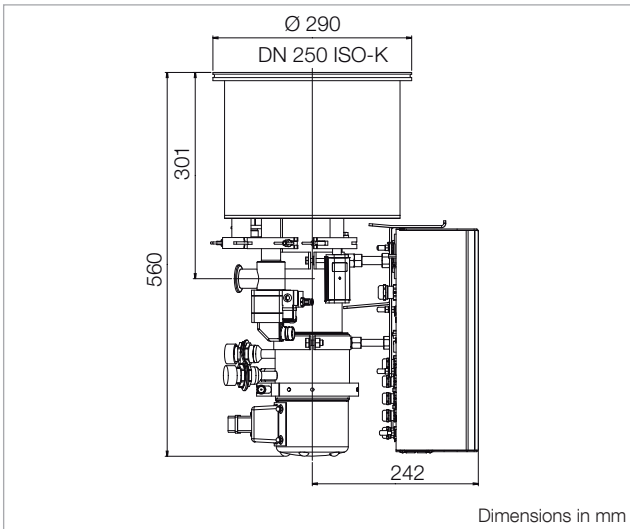

Dimensional drawing for the COOLVAC 2000 iCL (DN 250 ISO-K)

COOLVAC 3000 iCL



Advantages to the User

- Hydrocarbon-free high vacuum
- High capacity for argon and hydrogen
- High crossover value
- Simple operation
- Trouble-free integration into complex systems
- Fully automatic regeneration through integrated COOL.DRIVE controller ¹⁾
- Easy on-site servicing without pump disassembling and reconditioning of the vacuum system possible

Typical Applications

- Evaporators
- Sputtering systems
- Ion implanters
- Optical coating systems
- Metallization systems

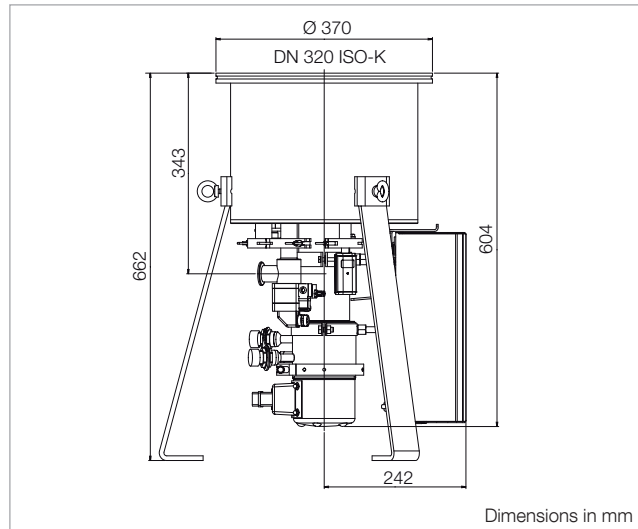

Dimensional drawing for the COOLVAC 3000 iCL (DN 320 ISO-K)

Technical Data

COOLVAC

		2000 iCL	3000 iCL
High vacuum (HV) flange	DN	250 ISO-K / 250 CF / 8" ANSI	320 ISO-K / 10" ANSI
Fore vacuum flange ²⁾	DN	25 ISO-KF	25 ISO-KF
Flange for connection a gauge head ³⁾	DN	16 ISO-KF	16 ISO-KF
Flange for the electrical connection	DN	16 CF	16 CF
Pressure-relief device with flange connection for gas exhaust line	DN	40 ISO-KF	40 ISO-KF
4-way current feedthrough for Si diode on a flange	DN	16 ISO-KF	16 ISO-KF
Heaters			
1st stage	W	160	160
	V AC	42	42
2nd stage	W	90	90
	V AC	42	42
Temperature sensor			
1st stage		Pt100	Pt100
2nd stage		Si diode	Si diode
Built-in cold head	COOLPOWER	7/25	7/25
Weight	kg (lbs)	29 (64)	35 (101.4)
Cooldown time to T ₂ = 20 K	min	70	120
Crossover value	mbar x l (Torr x l)	250 (187)	500 (375)
Pumping speed			
H ₂ O	l x s ⁻¹	7000	10500
Ar / N ₂	l x s ⁻¹	1600 / 2100	2500 / 3000
H ₂	l x s ⁻¹	3200	6000
Capacity			
Ar / N ₂	bar x l	1600 / 1600	2500 / 2500
H ₂ at 10 ⁻⁶ mbar	bar x l	15 ⁴⁾	28 ⁴⁾
Max. throughput			
Ar / N ₂	mbar x l x s ⁻¹ (Torr x l x s ⁻¹)	12 (9) / 12 (9)	15 (11.2) / 15 (11.2)
H ₂	mbar x l x s ⁻¹ (Torr x l x s ⁻¹)	6 (4.5) ⁴⁾	10 (7.5) ⁴⁾
Helium connections (Self-sealing couplings: outside thread, type 5400-S2-8)	DN	1/2"	1/2"

- 1) Accessories, necessary for automatic operations (i.e. electrical regeneration heaters, forevacuum valve DN 25 ISO-KF, and vacuum gauge DN 16 ISO-KF), are included with the scope of delivery and are connected to the integrated COOL.DRIVE.
- 2) Electropneumatic angle valve included.
- 3) Vacuum gauge head included.
- 4) The maximum throughput values given for hydrogen (H₂) are true for regenerated cryo pumps under short-term loads only. For continuous operations, both throughput and capacity values will be lower.

Ordering Information

COOLVAC 2000 iCL

	Single Operation		Dual operation		Multiple operation	
	Europe	USA/Japan	High Voltage	Low Voltage	High Voltage	Low Voltage
	Part No.		Part No.		Part No.	
COOLVAC 2000 iCL						
DN 250 CF	844251V0002		844251V0002 (2x)		844251V0002 (3x)	
DN 8" ANSI	844251V0004		844251V0004 (2x)		844251V0004 (3x)	
DN 250 ISO-K	844251V0006		844251V0006 (2x)		844251V0006 (3x)	

Compressors, flexlines and cables

Compressor						
CP 2000	840000V2000	-	-	-	-	-
CP 2200	-	840000V2200	-	-	-	-
CP 6000 H	-	-	840000V6001	-	840000V6001	-
CP 6200 H	-	-	-	840000V6201	-	840000V6201
Power supply cable for compressor	-		see Ordering Information of the compressor units			
Set of flexlines						
FL 4.5 (1/2", 1/2")	892 87		892 87 (2x)		892 87 (3x)	
or FL 9.0 (1/2", 1/2")	892 88		892 88 (2x)		892 88 (3x)	
or FL 18.0 HP (1/2") + FL 18.0 LP (1/2")	840203 + 840204		840203 (2x) + 840204 (2 x)		840203 (3x) + 840204 (3 x)	
Gas manifold (1 piece each)						
GD 2	-		840 253 (2x)		-	
GD 4	-		-		840 254 (2x)	
Compressor unit control cable ¹⁾						
COOLPAK control cable, 5 m	844231V4005		844231V4005 (2x)		844231V4005 (3x)	
or COOLPAK control cable, 10 m	844231V4010		844231V4010 (2x)		844231V4010 (3x)	
or COOLPAK control cable, 20 m	844231V4020		844231V4020 (2x)		844231V4020 (3x)	
COOLPAK adapter for multi control	-		844231V5003		844231V5003	

Optional electronics, cables and equipment

CRYOVISION control and display unit	844231V0002		844231V0002		844231V0002	
CRYOVISION control cables						
CRYOVISION control cable, 5 m	844231V2005		844231V2005		844231V2005	
or CRYOVISION control cable, 10 m	844231V2010		844231V2010		844231V2010	
or CRYOVISION control cable, 20 m	844231V2020		844231V2020		844231V2020	
Network control cable for the link between the pumps						
CRYOVISION / Network control cable, 5 m	-		844231V2005		844231V2005 (2x)	
or CRYOVISION / Network control cable, 10 m	-		844231V2010		844231V2010 (2x)	
or CRYOVISION / Network control cable, 20 m	-		844231V2020		844231V2020 (2x)	

Optional interface module

COOLVAC ProfiBus module ProfiBus - RS232 Converter for COOL.DRIVE and CRYOVISION either COOLVAC ProfiBus module connected to COOL.DRIVE control and monitoring unit of each cryo pump (in this case CRYOVISION and network control not to apply)	844000V1		844000V1 (2x)		844000V1 (3x)	
or COOLVAC ProfiBus module connected to CRYOVISION ²⁾	844000V1		844000V1		844000V1	

The arrangement of the components is shown in the chapter "Accessories" under the heading "COOLVAC iClassicLine, System Components".

1) The length of the control cable should match to the length of the flexlines.

2) At multiple operation with reduced communication speed to single cryo pumps.

Ordering Information

COOLVAC 3000 iCL

	Single Operation		Dual operation	
	Europe	USA/Japan	High Voltage	Low Voltage
	Part No.		Part No.	
COOLVAC 3000 iCL				
DN 10" ANSI	844321V0004		844321V0004 (2x)	
DN 320 ISO-K	844321V0006		844321V0006 (2x)	
Compressors, flexlines and cables				
Compressor				
CP 2000	840000V2000	-	-	-
CP 2200	-	840000V2200	-	-
CP 6000 H	-	-	840000V6001	-
CP 6200 H	-	-	-	840000V6201
Power supply cable for compressor	-		see Ordering Information of the compressor units	
Set of flexlines				
FL 4.5 (1/2", 1/2")	892 87		892 87 (2x)	
or FL 9.0 (1/2", 1/2")	892 88		892 88 (2x)	
or FL 18.0 HP (1/2") + FL 18.0 LP (1/2")	840203 + 840204		840203 (2x) + 840204 (2 x)	
Gas manifold (1 piece each)				
GD 2	-		840 253 (2x)	
Compressor unit control cable ¹⁾				
COOLPAK control cable, 5 m (16.4 ft)	844231V4005		844231V4005 (2x)	
or COOLPAK control cable, 10 m (32.81 ft)	844231V4010		844231V4010 (2x)	
or COOLPAK control cable, 20 m (65.62 ft)	844231V4020		844231V4020 (2x)	
COOLPAK adapter for multi control	-		844231V5003	
Optional electronics, cables and equipment				
CRYOVISION control and display unit	844231V0002		844231V0002	
CRYOVISION control cables				
CRYOVISION control cable, 5 m (16.4 ft)	844231V2005		844231V2005	
or CRYOVISION control cable, 10 m (32.81 ft)	844231V2010		844231V2010	
or CRYOVISION control cable, 20 m (65.62 ft)	844231V2020		844231V2020	
Network control cable for the link between the pumps				
CRYOVISION / Network control cable, 5 m (16.4 ft)	-		844231V2005	
or CRYOVISION / Network control cable, 10 m (32.81 ft)	-		844231V2010	
or CRYOVISION / Network control cable, 20 m (65.62 ft)	-		844231V2020	
Optional interface module				
COOLVAC ProfiBus module ProfiBus - RS232 Converter for COOL.DRIVE and CRYOVISION either COOLVAC ProfiBus module connected to COOL.DRIVE control and monitoring unit of each cryo pump (in this case CRYOVISION and network control not to apply)	844000V1		844000V1 (2x)	
or COOLVAC ProfiBus module connected to CRYOVISION ²⁾	844000V1		844000V1	

The arrangement of the components is shown in the chapter "Accessories" under the heading "COOLVAC iClassicLine, System Components".

1) The length of the control cable should match to the length of the flexlines.

2) At multiple operation with reduced communication speed to single cryo pumps.

COOLVAC 5000 iCL



Advantages to the User

- Hydrocarbon-free high vacuum
- High capacity for argon and hydrogen
- High crossover value
- Simple operation
- Trouble-free integration into complex systems
- Fully automatic regeneration through integrated COOL.DRIVE controller ¹⁾
- Easy on-site servicing without pump disassembling and reconditioning of the vacuum system possible

Typical Applications

- Evaporators
- Electron beam welding systems
- Ion implanters
- Optical coating systems
- Metallization systems

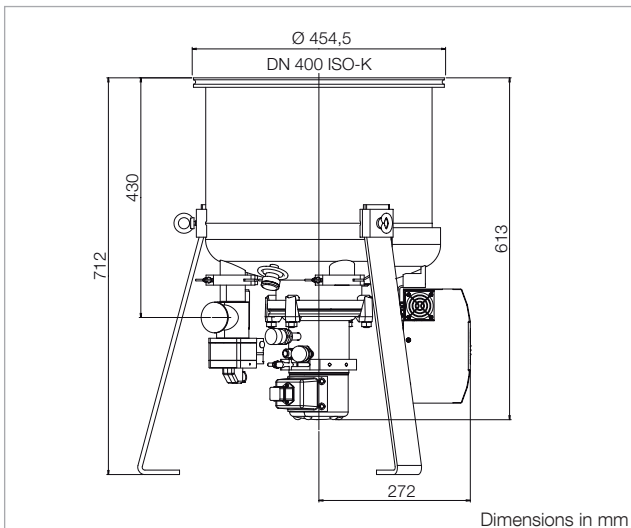

Dimensional drawing for the COOLVAC 5000 iCL

COOLVAC 10000 iCL



Advantages to the User

- Hydrocarbon-free high vacuum
- High capacity for argon and hydrogen
- High crossover value
- Simple operation
- Trouble-free integration into complex systems
- Fully automatic regeneration through integrated COOL.DRIVE controller ¹⁾
- Easy on-site servicing without pump disassembling and reconditioning of the vacuum system possible

Typical Applications

- Evaporators
- Electron beam welding systems
- Ion implanters
- Optical coating systems
- Metallization systems

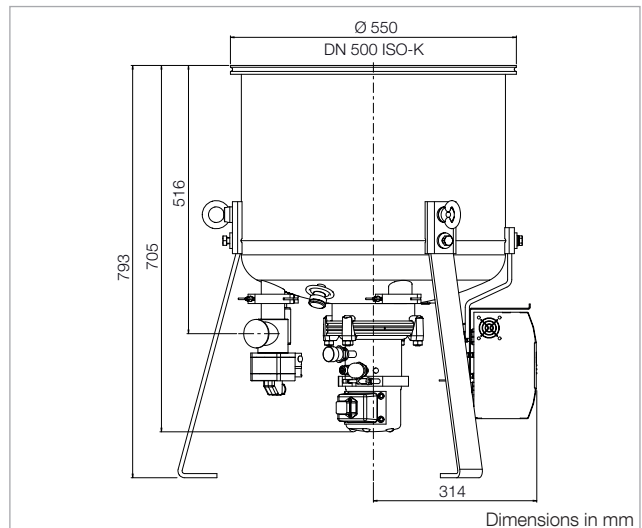

Dimensional drawing for the COOLVAC 10000 iCL

Technical Data

COOLVAC

5000 iCL

10000 iCL

High vacuum (HV) flange	DN	400 ISO-K	500 ISO-K / 500 - 20" ANSI
Fore vacuum flange ²⁾	DN	40 ISO-KF	40 ISO-KF
Flange for connection of a gauge head ³⁾	DN	16 ISO-KF	16 ISO-KF
Flange for the electrical connection	DN	40 ISO-KF	40 ISO-KF
Pressure-relief device with flange connection for gas exhaust line	DN	40 ISO-KF	40 ISO-KF
4-way current feedthrough for Si diode on a flange	DN	16 ISO-KF	16 ISO-KF
Heaters			
1st stage	W	160	160
	V AC	42	42
2nd stage	W	90	90
	V AC	42	42
Temperature sensor			
1st stage		Pt100	Pt100
2nd stage		Si diode	Si diode
Built-in cold head	COOLPOWER	5/100	5/100
Weight	kg (lbs)	53 (116.9)	70 (154.3)
Cooldown time to T ₂ = 20 K	min	100	150
Crossover value	mbar x l (Torr x l)	700 (525)	800 (600)
Pumping speed			
H ₂ O	l x s ⁻¹	18000	30000
Ar / N ₂	l x s ⁻¹	4000 / 5200	8400 / 10000
H ₂	l x s ⁻¹	6200	10000
Capacity			
Ar / N ₂	bar x l	3000 / 3000	5500 / 5500
H ₂ at 10 ⁻⁶ mbar	bar x l	32 ⁴⁾	45 ⁴⁾
Max. throughput			
Ar / N ₂	mbar x l x s ⁻¹ (Torr x l x s ⁻¹)	10 (7.5) / 10 (7.5)	10 (7.5) / 10 (7.5)
H ₂	mbar x l x s ⁻¹ (Torr x l x s ⁻¹)	7 (5.3) ⁴⁾	7 (5.3) ⁴⁾
Helium connection (Self-sealing couplings: outside thread, types 5400-S2-8	DN	1/2"	1/2"

- 1) Accessories, necessary for automatic operations (i.e. electrical regeneration heaters, forevacuum valve DN 25 ISO-KF, and vacuum gauge DN 16 ISO-KF), are included with the scope of delivery and are connected to the integrated COOL.DRIVE.
- 2) Electropneumatic angle valve included.
- 3) Vacuum gauge head included.
- 4) The maximum throughput values given for hydrogen (H₂) are true for regenerated cryo pumps under short-term loads only. For continuous operations, both throughput and capacity values will be lower.

Ordering Information

COOLVAC 5000 iCL

COOLVAC 10000 iCL

	High Voltage	Low Voltage	High Voltage	Low Voltage
	Part No.		Part No.	
COOLVAC 5000 iCL, DN 400 ISO-K	844411V0006		-	
COOLVAC 10000 iCL, DN 500 20" ANSI	-		844511V0004	
COOLVAC 10000 iCL, DN 500 ISO-K	-		844511V0006	
Compressors, flexlines and cables				
Compressor				
CP 6000 H	840000V6001	-	840000V6001	-
CP 6200 H	-	840000V6201	-	840000V6201
Power supply cable for compressor	see Ordering Information of the compressor units			
Set of flexlines				
FL 4.5 (1/2", 1/2")	892 87		892 87	
or FL 9.0 (1/2", 1/2")	892 88		892 88	
or FL 18.0 HP (1/2") + FL 18.0 LP (1/2")	840203 + 840204		840203 + 840204	
Compressor unit control cable ¹⁾				
COOLPAK control cable, 5 m (16.4 ft)	844231V4005		844231V4005	
or COOLPAK control cable, 10 m (32.81 ft)	844231V4010		844231V4010	
or COOLPAK control cable, 20 m (65.62 ft)	844231V4020		844231V4020	
Optional electronics, cables and equipment				
CRYOVISION control and display unit	844231V0002		844231V0002	
CRYOVISION control cables				
CRYOVISION control cable, 5 m (16.4 ft)	844231V2005		844231V2005	
or CRYOVISION control cable, 10 m (32.81 ft)	844231V2010		844231V2010	
or CRYOVISION control cable, 20 m (65.62 ft)	844231V2020		844231V2020	
Optional interface module				
COOLVAC ProfiBus module ProfiBus - RS232 Converter for COOL.DRIVE and CRYOVISION	844000V1		844000V1	

The arrangement of the components is shown in the chapter "Accessories" under the heading "COOLVAC iClassicLine, System Components".

1) The length of the control cable should match to the length of the flexlines.

COOLVAC 18000 iCL



COOLVAC 18000 iCL with flange DN 630 ISO-F

Advantages to the User

- Hydrocarbon-free high vacuum
- High pumping speed for water vapor and nitrogen
- Fast, safe and efficient regeneration with the electric regeneration system ¹⁾
- Simple operation

Typical Applications

- Space simulation chambers
- Evaporators
- Electron beam welding systems
- Optical coating systems
- Metallization systems

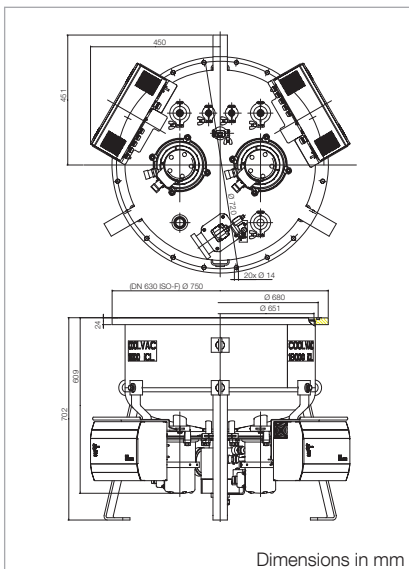

Dimensional drawing for the COOLVAC 18000 iCL

COOLVAC 30000 iCL



COOLVAC 30000 iCL with special flange

Advantages to the User

- Hydrocarbon-free high vacuum
- High pumping speed for water vapor and nitrogen
- Fast, safe and efficient regeneration with the electric regeneration system ¹⁾
- Simple operation

Typical Applications

- Space simulation chambers
- Evaporators
- Electron beam welding systems
- Optical coating systems
- Metallization systems

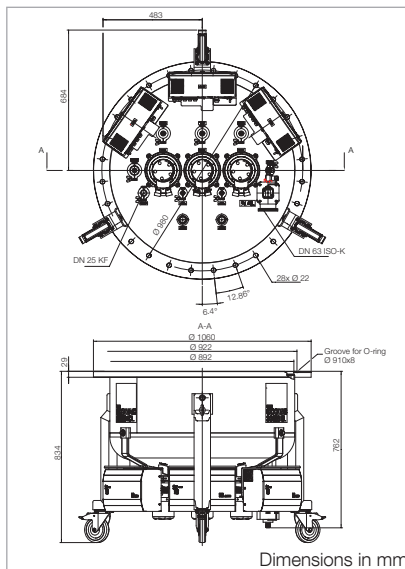

Dimensional drawing for the COOLVAC 30000 iCL

COOLVAC 60000 iCL



COOLVAC 60000 iCL with flange DN 1250 ISO-F

Advantages to the User

- Hydrocarbon-free high vacuum
- High pumping speed for water vapor and nitrogen
- Fast, safe and efficient regeneration with the electric regeneration system ¹⁾
- Simple operation

Typical Applications

- Space simulation chambers
- Evaporators
- Electron beam welding systems
- Optical coating systems
- Metallization systems

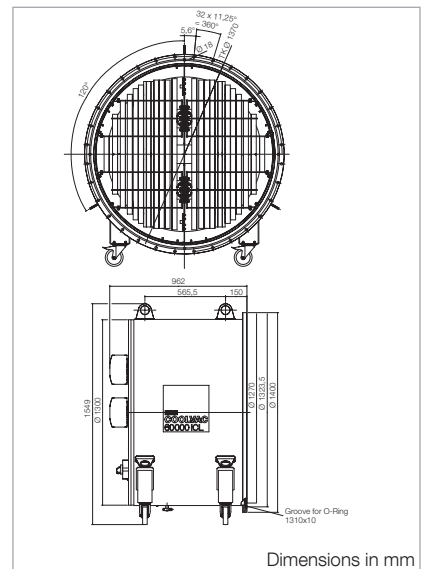

Dimensional drawing for the COOLVAC 60000 iCL

Technical Data

COOLVAC 18000 iCL COOLVAC 30000 iCL COOLVAC 60000 iCL

High vacuum flange	DN	630 ISO-F	35"ANSI	1250 ISO-F
Fore vacuum flange ²⁾	DN	63 ISO-K	63 ISO-K	63 ISO-K
Flange with current feedthrough for silicon diode	DN	25 ISO-KF (2x)	16 ISO-KF (2x)	16 ISO-KF (2x)
Flange for other purposes	DN	40 ISO-KF	-	-
Flange with 11-way feedthrough with additional Pt 100 on flange	DN	-	40 ISO-KF	40 ISO-KF
Pressure-relief device with flange connection for gas exhaust line	DN	40 ISO-KF	40 ISO-KF	40 ISO-KF
Pumping speed				
H ₂ O	l x s ⁻¹	46000	93000	180000
Ar / N ₂	l x s ⁻¹	13500 / 18000	25000 / 30000	47000 / 57000
H ₂	l x s ⁻¹	14000	30000	60000
Capacity				
Ar / N ₂	bar x l	6000	6500	9000
H ₂ at 10 ⁻⁶ mbar	bar x l	65 ³⁾	100 ³⁾	150 ³⁾
Built-in cold head	COOLPOWER	5/100 (2x)	5/100 (2x) and 140T (1x)	5/100 (2x) and 140T (2x)
Max. throughput				
Ar / N ₂	mbar x l x s ⁻¹ (Torr x l x s ⁻¹)	14 (10.5)	14 (10.5)	25 (18.75)
H ₂	mbar x l x s ⁻¹ (Torr x l x s ⁻¹)	7 (5.25) ³⁾	7 (5.25) ³⁾	12 (9) ³⁾
Crossover value at 20 K	mbar x l (Torr x l)	800 (600)	1200 (900)	1000 (750)
Cool down time to 20 K	min	180	260	330
Overall height	mm	see drawing	see drawing	see drawing
Weight	kg (lbs)	131 (289)	262 (577.6)	503 (1109)
Silicon diode for temperature measurements at the second stage of the cold head		built-in (2x)	built-in (2x)	built-in (2x)
Regeneration heaters at the first stage of the cold head		built-in (2x)	built-in (3x)	built-in (4x)
second stage of the cold head		built-in (2x)	built-in (2x)	built-in (2x)

1) Accessories, necessary for automatic operations (i.e. electrical regeneration heaters, forevacuum valve DN 63 ISO-KF, and vacuum gauge DN 16 ISO-KF), are included with the scope of delivery and are connected to the integrated COOLDRIVE.

2) Electropneumatic angle valve included.

3) The maximum throughput values given for hydrogen (H₂) are true for regenerated cryo pumps under short-term loads only. For continuous operations, both throughput and capacity values will be lower.

Ordering information

COOLVAC 18000 iCL **COOLVAC 30000 iCL** **COOLVAC 60000 iCL**
 High Voltage Low Voltage High Voltage Low Voltage High Voltage Low Voltage

	Part No.	Part No.	Part No.
COOLVAC 18 000 iCL, DN 630 ISO-F	844631V0006	-	-
COOLVAC 30 000 iCL, 35" ANSI	-	844891V9005	-
COOLVAC 60 000 iCL, DN 1250 ISO-F	-	-	844896V9005

Compressors, flexlines and cables

Compressor	Part No.	Part No.	Part No.
CP 6000 H	840000V6001 (2x)	-	840000V6001 (4x)
CP 6200 H	-	840000V6201 (2x)	840000V6201 (4x)
Power supply cable for compressor	see Ordering Information of the compressor units		
Set of flexlines			
FL 4.5 (1/2", 1/2")	892 87 (2x)	892 87 (3x)	892 87 (4x)
or FL 9.0 (1/2", 1/2")	892 88 (2x)	892 88 (3x)	892 88 (4x)
or FL 18.0 HP (1/2") + FL 18.0 LP (1/2")	840203 (2x) + 840204 (2x)	840203 (3x) + 840204 (3x)	840203 (4x) + 840204 (4x)
Compressor unit control cable ¹⁾			
COOLPAK control cable, 5 m (16.4 ft)	844231V4005 (2x)	844231V4005 (3x)	844231V4005 (4x)
or COOLPAK control cable, 10 m (32.81 ft)	844231V4010 (2x)	844231V4010 (3x)	844231V4010 (4x)
or COOLPAK control cable, 20 m (65.62 ft)	844231V4020 (2x)	844231V4020 (3x)	844231V4020 (4x)

Optional electronics, cables and equipment

CRYOVISION control and display unit	844231V0002
CRYOVISION network / control cable	
CRYOVISION / Network control cable, 5 m (16.4 ft)	844231V2005
or CRYOVISION / Network control cable, 10 m (32.81 ft)	844231V2010
or CRYOVISION / Network control cable, 20 m (65.62 ft)	844231V2020

Optional interface module

COOLVAC ProfiBus module ProfiBus - RS232 Converter for COOL.DRIVE and CRYOVISION	844000V1
---	----------

The arrangement of the components is shown in the chapter "Accessories" under the heading "COOLVAC iClassicLine, System Components".

1) The length of the control cable should match to the length of the flexlines.

Cryo Pumps for Manual Operation, BasicLine

The COOLVAC cryo pumps of the BasicLine version are identical to the COOLVAC cryo pumps of the iClassicLine version concerning the technical data for pumping speed, capacity, cooldown time, built-in cold heads, maximum throughput, built-in temperature sensors for the second stage (Si diode) and the corresponding current feedthroughs.

The standard BasicLine models do **not** include the following components:

- Electrical regeneration heaters
- Temperature sensors for the first stages of the cold head(s)
- Vacuum gauge head
- Fore vacuum valve
- Temperature readout / display unit for the silicon diode(s)

We are glad to advise you of our assortment of accessories for our COOLVAC BasicLine range of cryo pumps.

All cryo pumps of the *iClassicLine* series (iCL) described above can be delivered as *Basicline* types, too. Please consult with our technical support, cf. page 148

E.g. for the following part numbers:

	Part No.
COOLVAC 10000 BL-V, DN 500 20" ANSI	844511V1004
COOLVAC 10000 BL-V, DN 500 ISO-K	844511V1006

Cryo Pumps with Liquid Nitrogen Cooling of Radiation Shield and Baffle of Cryo Pump

COOLVAC 30000 BL LN₂ and COOLVAC 60000 BL LN₂



COOLVAC 30000 BL LN₂



COOLVAC 60000 BL LN₂ with flange DN 1250 ISO-F

Advantages to the User

- Hydrocarbon-free high vacuum
- High pumping speed for water vapor and nitrogen
- Operating with only one compressor unit through liquid nitrogen (LN₂) cooling of radiation shield and baffle
- Controlling of radiation shield and baffle temperatures by additional temperature sensor

Typical Applications

- Space simulation chambers
- Vacuum furnaces

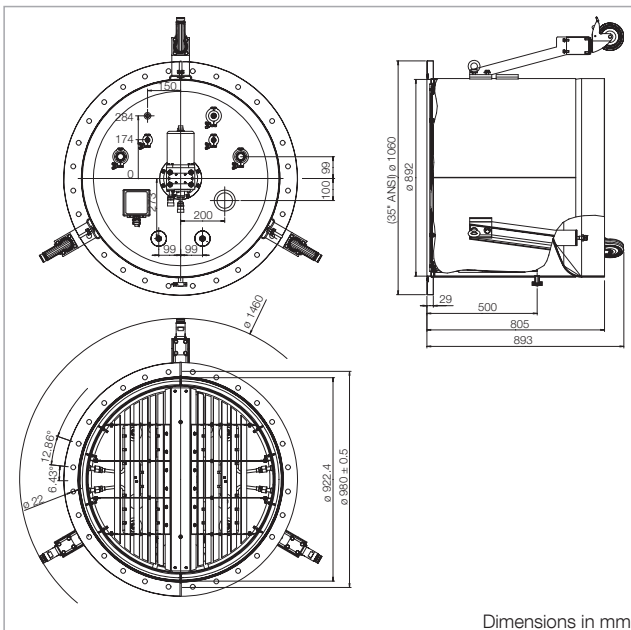

Dimensional drawing of COOLVAC 30000 BL LN₂

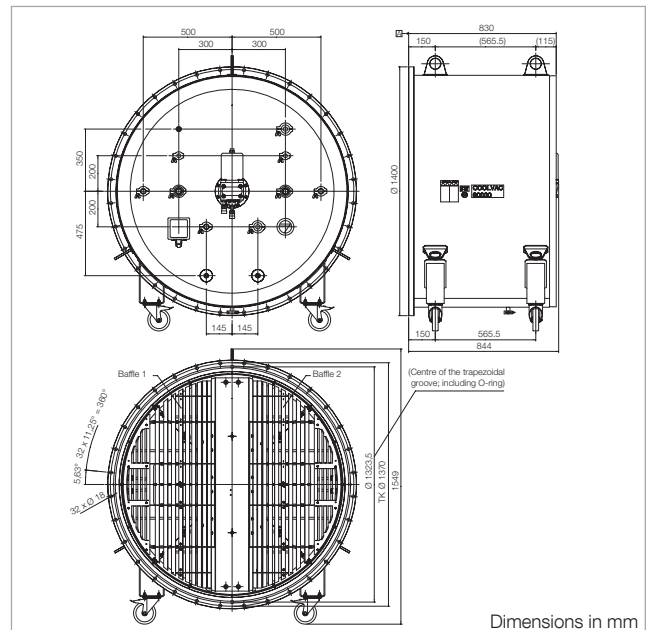

Dimensional drawing of COOLVAC 60000 BL LN₂

Technical Data

COOLVAC 30000 BL LN₂

COOLVAC 60000 BL LN₂

High vacuum flange	DN	35"ANSI	1250 ISO-F
Fore vacuum flange	DN	63 ISO-K	63 ISO-K
Flange with 4-pole current feedthrough for silicon diode*	DN	16 ISO-KF (2x)	16 ISO-KF (2x)
Flange with 6-pole current feedthrough for 3 Pt 100 (radiation shield and baffle halves)	DN	40 ISO-KF	40 ISO-KF
Pressure-relief device with flange connection for gas exhaust line	DN	40 ISO-KF	40 ISO-KF
Flange with abnormal temperature protection for the regeneration heaters of the built-in cold head	DN	40 ISO-KF	40 ISO-KF
Pumping speed			
H ₂ O	l x s ⁻¹	93000	180000
Ar / N ₂	l x s ⁻¹	25000 / 30000	47000 / 57000
H ₂	l x s ⁻¹	30000	60000
Capacity			
Ar / N ₂	bar x l	6500	9000
H ₂ at 10 ⁻⁶ mbar	bar x l	100 ¹⁾	150 ¹⁾
Built-in cold head	COOLPOWER	10 MD	10 MD)
Max. throughput			
Ar / N ₂	mbar x l x s ⁻¹ (Torr x l x s ⁻¹)	> 15 (11.25) ¹⁾	> 30 (22.5) ¹⁾
Crossover value at 20 K	mbar x l (Torr x l)	2000 (1500)	3000 (2250)
LN ₂ consumption, ca.	l/h	7	10
LN ₂ connections		SS-8-VCR (1/2")	SS-8-VCR (1/2")
Cool down time to 20 K, approx.	h	5	6
Overall height	mm	see drawing	see drawing
Weight, approx.	kg (lbs)	300 (661)	400 (882)
Silicon diode for temperature measurements at the second stage of the cold head		built-in	built-in
Regeneration heaters at the			
first stage of the cold head		built-in	built-in
second stage of the cold head		built-in	built-in

* temperature sensor at the second stage of the cold head.

¹⁾ The maximum throughput values given for hydrogen (H₂) are true for regenerated cryo pumps under short-term loads only. For continuous operations, both throughput and capacity values will be lower.

Ordering information

COOLVAC 30000 BL LN₂
High Voltage Low Voltage

COOLVAC 60000 BL LN₂
High Voltage Low Voltage

	Part No.	Part No.
COOLVAC 30 000 BL LN ₂ , 35" ANSI	844890V9501	-
COOLVAC 60 000 BL LN ₂ , DN 1250 ISO-F	-	844895V9503

Compressors, flexlines and cables

Compressor	840000V6002	-	840000V6002	-
CP 6000 HMD, 400 V / 50 Hz / 460 V / 60 Hz / 3-ph.	840000V6002	-	840000V6002	-
CP 6200 HMD, 200 V / 50 Hz / 200 - 230 V / 60 Hz / 3-ph.	-	840000V6202	-	840000V6202
Power supply cable for compressor	see Ordering Information of the compressor units			
Flexible pressure line (for operating mechanically driven cold heads)				
9 m (29.53 ft), FL9 HP - DN20 (8f/8f) + FL9 LP - DN32 (8f/8f)	840217 + 840218V0032			
20 m (65.62 ft), FL20 HP - DN20 (8f/8f) + FL20 LP - DN32 (8f/8f)	840230V2020 + 840231V2032			
Cable cold head motor compressor unit ¹⁾				
9 m (29.53 ft)	842 110			
20 m (65.62 ft)	842 112			

Optional equipment and cables

Low temperature measuring instrument MODEL 211S	844 110
HV cable, 4-way, with plug to the MODEL 211S	
10 m (32.81 ft)	844 113
20 m (65.62 ft)	844113V20

Additional accessories (selection)

Forevacuum valves ²⁾	
Right-Angle DN 63 ISO-K, electropneumatically operated, with pilot valve 24 V DC, Aluminum body	10800V01
Right-Angle DN 63 ISO-K, electropneumatically operated, with pilot valve 24 V DC, stainless steel body	10810V01
Pressure sensor	
THERMOVAC Transmitter TTR 91 N, DN 16 ISO-KF (without switching threshold)	230035V02
THERMOVAC Transmitter TTR 91 N, DN 16 ISO-KF, (with switching threshold, 2SP)	230040V02
Connection cable to TTR 91 N, FCC 68 on both ends, 8-way shielded ³⁾	Typ A
10 m (32.81 ft)	230 012
20 m (65.62 ft)	124 28
30 m (98.43 ft)	124 29

1) The length of the control cable should match to the length of the flexlines.

2) See catalog "Valves" for additional right-angle valves.

3) The length of the control cable should match to the length of the flexlines.

Products Cryogenics

Cold Heads, Pneumatically Driven Single-Stage Cold Heads COOLPOWER 50 and 140 T

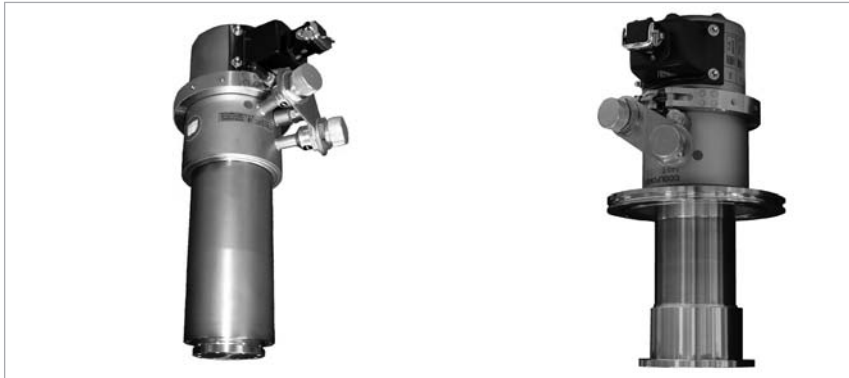

Single-stage cold head's COOLPOWER 50 (left) and 140 T (right)

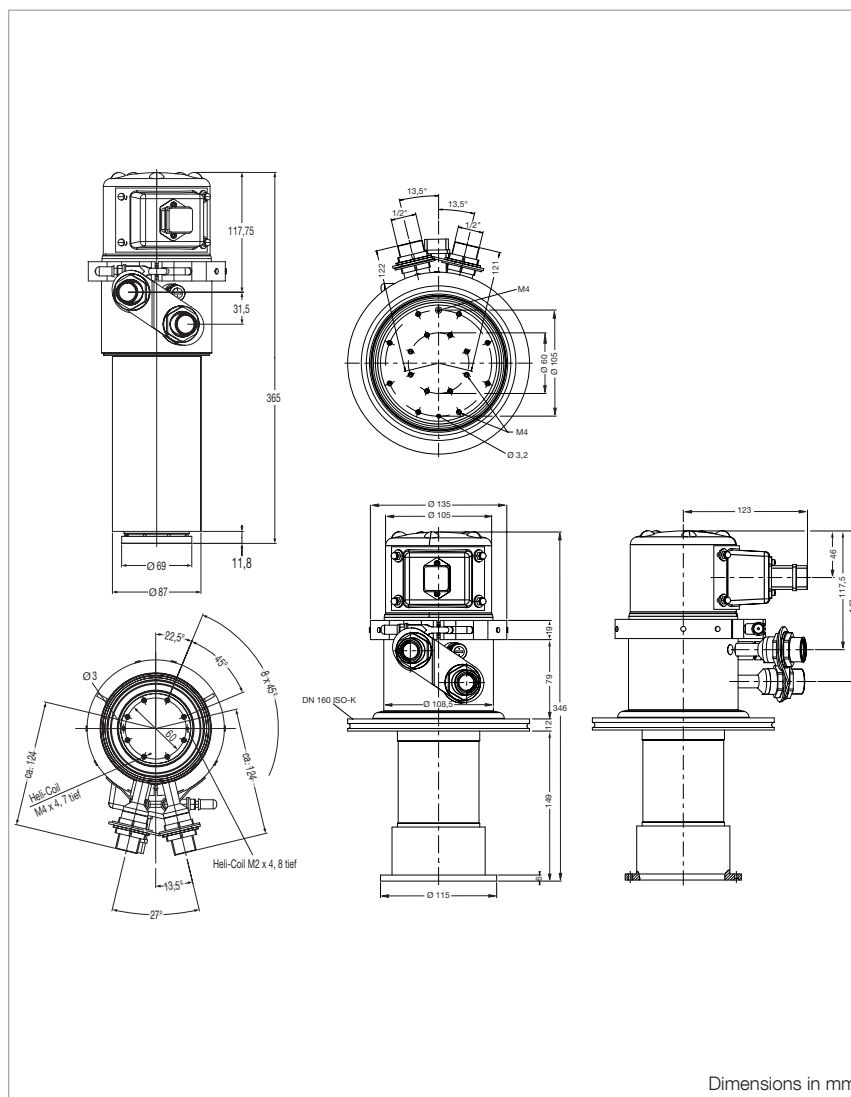

Dimensional drawing for the COOLPOWER 50 (left) and COOLPOWER 140 T (right)

Advantages to the User

- For installation mostly in any orientation
- High refrigerating capacity
- No liquid refrigerants are required
- Very simple to operate
- Short cooldown time

Typical Applications

- Cooling of samples, sensors and detectors
 - e. g. cooling of detectors in astronomy
- Cooling of HTS superconductors
- Cooling in magnetic equipment
- Cooling of surfaces for pumping of gases
- Cryogenic process gas cleaning
- Condensation, resublimation and freezing of gases

Technical Data

COOLPOWER 50

COOLPOWER 140 T

Refrigeration capacity at 50/60 Hz ¹⁾			
at 80 K, approx.	W	50	140
at 20 K, approx.	W	-	20
Lowest attainable temperature ¹⁾	K	≤ 26	≤ 15
Cooldown time down			
to 20 K, approx.	min	-	55
to 80 K, approx.	min	20	-
Permissible ambient temperature	°C (°F)	+10 to +40 (+50 to +104)	+10 to +40 (+50 to +104)
He filling pressure at room temperature	barg	16 ₋₁	16 ₋₁
He connections			
Self-sealing screwed connections			
High pressure connection		1/2" ²⁾	1/2" ²⁾
Low pressure connection		1/2" ²⁾	1/2" ²⁾
Weight	kg (lbs)	8 (17.7)	12 (26.5)

Ordering Information

COOLPOWER 50

COOLPOWER 140 T

	Part No.		Part No.		
Cold head					
with DN 100 CF-R (rotatable)	842050V0001	-	-	-	-
with DN 160 CF-R (rotatable)	-	-	-	842030V9004	-
with DN 160 ISO-K	842050V0002	-	842 030	-	-
with weld-on pipe	-	842050V0000	-	-	842030V0001
Distance Flange - Cold stage	mm	149.5	-	148.5	111.4

Accessories

Compressor unit (for operation of one cold head)		
COOLPAK 2000, 230 V / 50 Hz	840000V2000	-
COOLPAK 2200, 208 V / 60 Hz	840000V2200	-
COOLPAK 6000 H, 400 V/50 Hz; 470 V / 60 Hz	-	840000V6001
COOLPAK 6200 H, 200 V/50 Hz; 200 V, 230 V / 60 Hz	-	840000V6201
Power supply cable	-	see Ordering Information for the compressor units COOLPAK
Set of flexlines		
FL 4.5 (1/2", 1/2") (= 1 Set)	892 87	892 87
FL 9.0 (1/2", 1/2") (= 1 Set)	892 88	892 88
FL 18.0 HP (1/2") (= Single line high pressure)	840 203	840 203
FL 18.0 LP (1/2") (= Single line low pressure)	840 204	840 204
Connecting cable compressor – cold head		
Power cord 4.5 m (15.75 ft)	E 400000323	E 400000323
Power cord 18 m (59.06 ft)	840002964V0018	840002964V0018
Extension cord 4.5 m (15.75 ft)	893 74	893 74

Options

Temperature measurement		
Silicon diode	844000V5	844000V5
Low temperature measuring instrument	844 110	844 110
Measuring cable	see Ordering Information low tempera- ture measuring instrument	see Ordering Information low tempera- ture measuring instrument

¹⁾ The refrigerating capacities and temperatures stated apply only to vertical operation with the cold end at the bottom.

²⁾ Series 5400 from Aeroquip, coupling size "-8" (#8), or compatible types.

Dual-Stage Cold Heads

COOLPOWER 7/25 and 5/100



Dual-stage cold head COOLPOWER 7/25



Dual-stage cold heads COOLPOWER 5/100

Advantages to the User

- For installation in any orientation
- High refrigerating capacity
- No liquid refrigerants are required
- Very simple to operate
- Short cooldown time

Typical Applications

- Cooling of samples, sensors and detectors
- Cooling of detectors in astronomy
- Cooling of samples for spectroscopy
- Cooling of samples for applications in medicine and R&D

- Cooling of HTS superconductors
- Cooling in magnetic equipment
- Cooling of surfaces for pumping of gases
- Cryogenic process gas cleaning
- Condensation, resublimation and freezing of gases

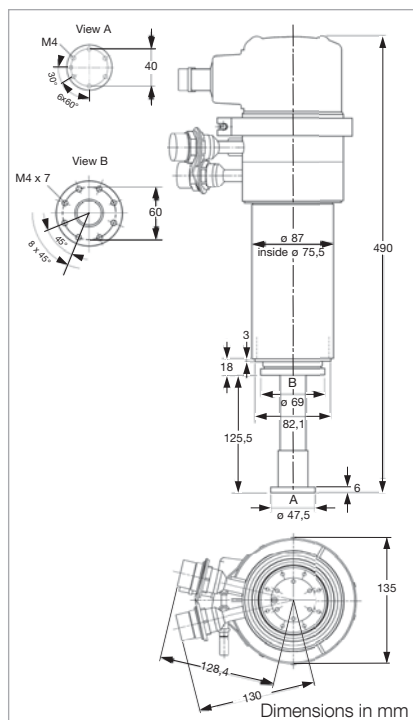

Dimensional drawing for the COOLPOWER 7/25

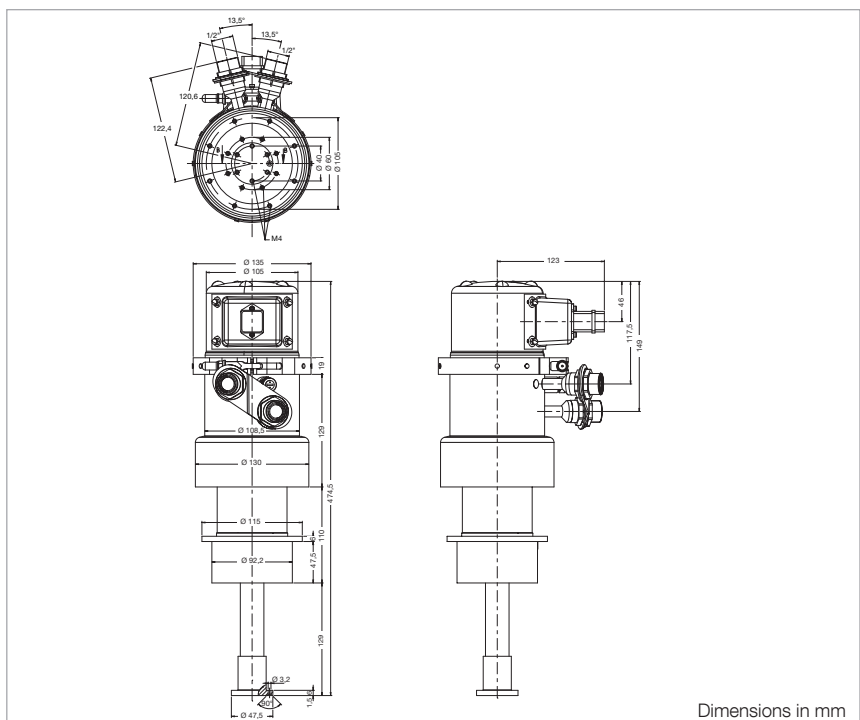

Dimensional drawing for the COOLPOWER 5/100

Technical Data

COOLPOWER 7/25

COOLPOWER 5/100

Refrigeration capacity at 50/60 Hz ¹⁾			
1st stage at 80 K, approx.	W	25	100
2nd stage at 20 K, approx.	W	7	6
Lowest attainable temperature ¹⁾			
1st stage, approx.	K	≤ 35	≤ 35
2nd stage, approx.	K	≤ 10	≤ 10
Cooldown time of the			
2nd stage to 20 K, approx.	min	35	25
Permissible ambient temperature	°C (°F)	+5 to +40 (+41 to +104)	+5 to +40 (+41 to +104)
He filling pressure at room temperature	barg	16 ₋₁	16 ₋₁
He connections			
Self-sealing screwed connections			
High pressure connection		1/2" (#8 ²⁾)	1/2" (#8 ²⁾)
Low pressure connection		1/2" (#8)	1/2" (#8)
Weight, approx.	kg (lbs)	10 (22,1)	10,5 (23,2)

Ordering Information

COOLPOWER 7/25

COOLPOWER 5/100

	Part No.	Part No.
Cold head		
COOLPOWER 7/25		
- with weld-on pipe	842 040	-
- with Flange DN 160 ISO-K	842 040V0002	-
(Space Flange - 2. Stage = 250 mm)		
- with Flange DN 100 CF-R (rotatable)	842 040V0005	-
(Space Flange - 2. Stage = 275 mm)		
COOLPOWER 5/100		
- with weld-on pipe	-	893 05
- with Flange DN 160 ISO-K	-	893 04
(Space Flange - 2. Stage = 277,5 mm)		
- with Flange DN 100 CF-R (rotatable)	-	842021V0001
(Space Flange - 2. Stage = 265,5 mm)		

Accessories

Compressor unit		
(for operation of one cold head)		
COOLPAK 2000, 230 V / 50 Hz	840000V2000	-
COOLPAK 2200, 208 V / 60 Hz	840000V2200	-
COOLPAK 6000 H		
400 V/50 Hz; 470 V / 60 Hz	-	840000V6001
COOLPAK 6200 H		
200 V/50 Hz; 200 V, 230 V / 60 Hz	-	840000V6201
Power supply cable	-	see Ordering Information for the compressor units COOLPAK
Set of flexlines		
FL 4.5 (1/2", 1/2") (= 1 Set)	892 87	892 87
FL 9.0 (1/2", 1/2") (= 1 Set)	892 88	892 88
FL 18.0 HP (1/2") (= Single line high pressure)	840 203	840 203
FL 18.0 LP (1/2") (= Single line low pressure)	840 204	840 204
Connecting cable compressor – cold head		
Power cord 4.5 m (15.75 ft)	E 400000323	E 400000323
Power cord 18 m (59.06 ft)	840002964V0018	840002964V0018
Extension cord 4.5 m (15.75 ft)	893 74	893 74

Options

Temperature measurement / control		
Silicon diode	844000V5	844000V5
Low temperature measuring instrument	844 110	844 110
Measuring cable	see Ordering Information low temperature measuring instrument	see Ordering Information low temperature measuring instrument

¹⁾ The refrigerating capacities and temperatures stated apply only to vertical operation with the cold end at the bottom.

²⁾ Series 5400 from Aeroquip, coupling size "-8" (#8), or compatible types.

Cold Heads, Mechanically Driven

Single-Stage Cold Head COOLPOWER 250 MD

Dual-Stage Cold Head COOLPOWER 10 MD



Single-stage Cold Head COOLPOWER 250 MD



Dual-stage Cold Head COOLPOWER 10 MD

Advantages to the User

- Excellent cooling performance
- up to 250 W at 80 K by press-button operation ^{1) 2)} (COOLPOWER 250 MD)
- 18 W at 20 K by press-button operation (COOLPOWER 10 MD)
- High reliability
- Design optimized for MTBF 100,000 h
- Long and maintenance-free operation
- Low vibration due to directly driven displacer
- No liquid refrigerants are required
- Very simple to operate
- Short cooldown time
- Easy operation
- Plug & Cool - as usual for all Leybold GM coolers
- Simple variation of motor speed via the COOLPAK MD compressor unit

COOLPOWER 250 MD – one of the strongest single-stage GM cooler available on the market:

- High cooling capacity of > 175 W at 80 K
- Cooling capacity up to 250 W at 80 K possible ^{1) 2)}

COOLPOWER 10 MD - the strongest 10 K GM cooler available on the market:

- High 2nd stage cooling capacity of > 18 W at 20 K
- High 1st stage cooling capacity of > 25 W at 40 K and 110 W at 80 K

Typical Applications

The COOLPOWER 250 MD is a mechanically driven single-stage Gifford McMahon (GM) cryo cooler and ideally suited for

- Shield cooling of superconducting magnets in MRI
- Cooling of cryopanels in special Cryo pumps
- Cooling of larger samples and devices; especially
 - High temperature superconductor coils, wires and bulk materials
 - Recondensation of liquid refrigerants such as nitrogen and argon
 - Cleaning of gases
 - Samples for spectroscopic investigations in solid state and surface physics
 - Infrared and gamma detectors
- Calibration of sensors

The COOLPOWER 10 MD is a mechanically driven double-stage Gifford McMahon (GM) cryo cooler and ideally suited for

- Cooling of cryo probes in NMR spectrometers
- Shield cooling of superconducting magnets in MRI
- Cooling of cryopanels in special Cryo pumps and thus generation of high vacuum and ultra-high vacuum pressures
- Cooling of larger samples and devices; especially
 - High temperature superconductor coils, wires and bulk materials
 - Recondensation of liquid refrigerants such as H₂, Ne
 - Samples for spectroscopic investigations in solid state and surface physics
 - Infrared and gamma detectors
- Calibration of sensors

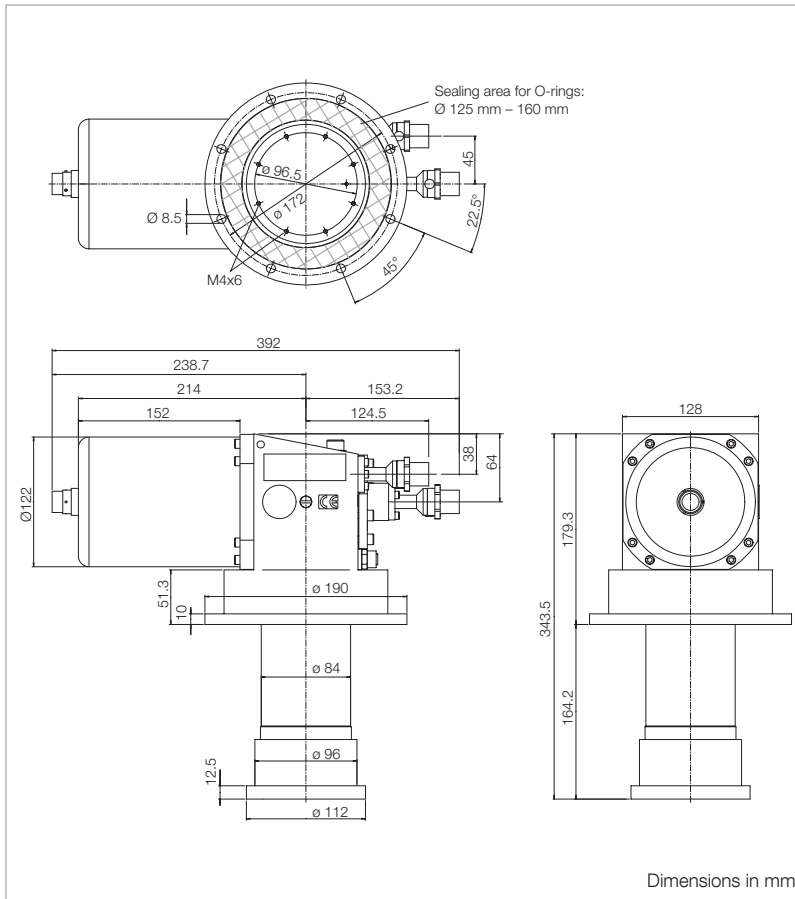

Dimensional drawing for the COOLPOWER 250 MD

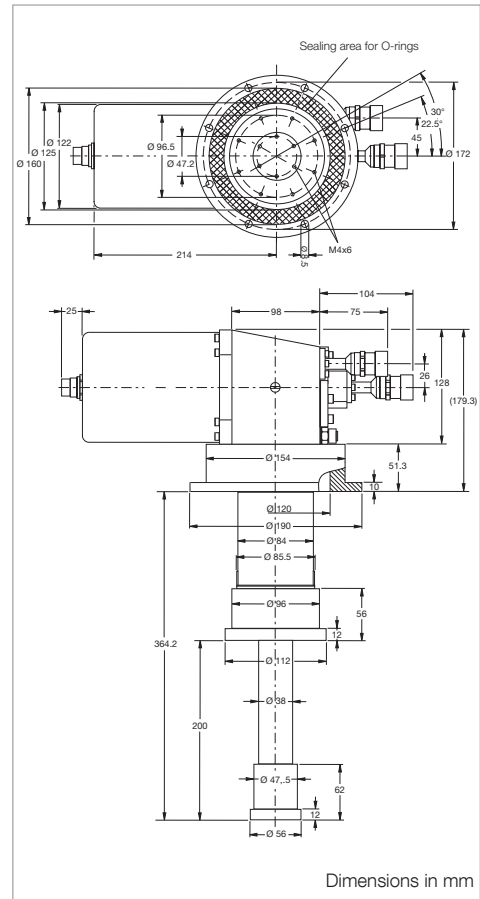

Dimensional drawing for the COOLPOWER 10 MD

Technical Data

COOLPOWER 250 MD

COOLPOWER 10 MD

Refrigeration capacity at 50/60 Hz ¹⁾			
1st stage at 80 K, approx.	W	175 ²⁾	110
2nd stage at 20 K, approx.	W	n/a	18
Lowest attainable temperature ¹⁾			
1st stage, approx.	K	\leq 25	\leq 28
2nd stage, approx.	K	n/a	\leq 8
Cooldown time of the			
1st stage to 80 K, approx.	min	35	n/a
2nd stage to 20 K, approx.	min	n/a	25
Permissible ambient temperature	$^{\circ}$ C ($^{\circ}$ F)	+5 to +40 (+41 to +104)	
He filling pressure at room temperature	barg	15 ₁	
He connections			
Self-sealing screwed connections			
High pressure connection		1/2" (#8 ³⁾)	1/2" (#8 ³⁾)
Low pressure connection		1/2" (#8)	1/2" (#8)
Weight, approx.	kg (lbs)	21 (46.3)	22 (48.5)

¹⁾ The refrigerating capacities and temperatures stated apply to vertical operation with the cold end at the bottom and with cold head motor rotation speed 120 RPM, He system filling pressure 13 barg, compressor unit COOLPAK 6000 HMD / 6200 HMD and mit flexlines FL 9.0 HP - DN20 (840217) and FL 9.0 LP - DN32 (840218V0032).

²⁾ Higher refrigeration capacities of up to 250 W at 80 K (CP 250 MD) can be achieved with special parameters and accessories in consultation with our technical support team.

³⁾ Series 5400 " - 8" from Aeroquip.

Ordering Information

COOLPOWER 250 MD

COOLPOWER 10 MD

	Part No.	Part No.
Cold head		
COOLPOWER 250 MD	842015V0001	-
COOLPOWER 250 MD; DN 160 CF-R (rotatable)	842015V0002	-
COOLPOWER 10 MD	-	842010
COOLPOWER 10 MD; DN 160 CF-R (rotatable)	-	842010V0002
Accessories		
Compressor unit		
COOLPAK 6000 HMD, 400 V/3-ph. 50 Hz or 460 V/3-ph. 60 Hz ± 10%	840000V6002	840000V6002
COOLPAK 6200 HMD, 200 V/3-ph. 50 Hz or 200-230 V/3-ph. 60 Hz ± 10%	840000V6202	840000V6202
Power supply cable	see Ordering Information for the compressor unit COOLPAK	see Ordering Information for the compressor unit COOLPAK
Flexible pressure line (for operating mechanically driven cold heads)		
9 m (31.5 ft) (High-pressure) FL9 HP-DN 20 (8f/8f)		840 217
9 m (31.5 ft) (Low-pressure) FL9 LP-DN 32 (8f/8f)		840218V0032
20 m (75.0 ft) (High-pressure) FL20 HP-DN 20 (8f/8f)		840230V2020
20 m (75.0 ft) (Low-pressure) FL20 LP-DN 32 (8f/8f)		840231V2032
Connection cable for the cold heads		
COOLPOWER 250 MD, 10 MD		
9,0 m		842 110
20,0 m		842 112

Compressor Units for Pneumatically Driven Cold Heads and Pumps, Water Cooling

COOLPAK 2000/2200



Compressor unit COOLPAK 2000 (2200 is similar)

Advantages to the User

- High efficiency and increased performance for cryogenic pumps and refrigerators
- High long-term reliability due to long-life and highly efficient components and improved oil management
- Very quiet and low vibration operation through the innovative horizontally suspended scroll compressor
- Simple installation and operation
- Global mains voltage compatibility
- Perfect integration within complex systems due to the 24 V Sub-D interface
- Simple adsorber replacement, otherwise maintenance-free
- Small footprint
- Low cost of ownership

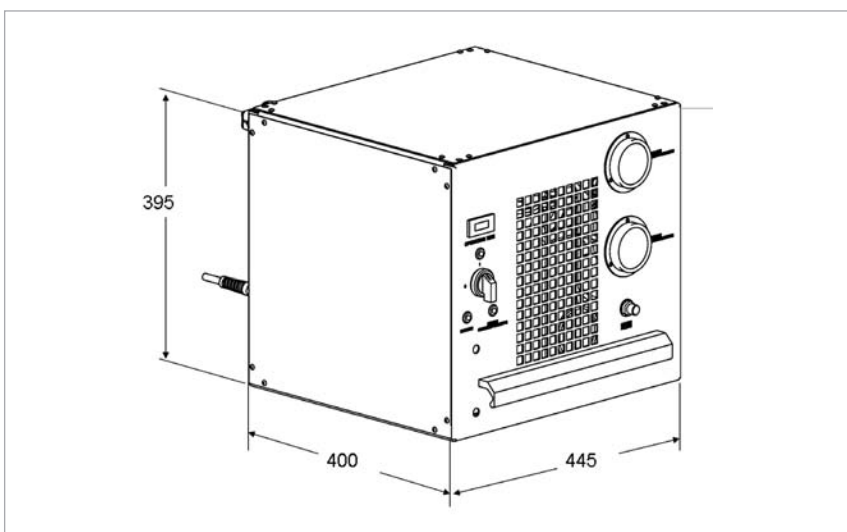

Dimensional drawing of the COOLPAK 2000/2200

Technical Data
COOLPAK 2000 (50 Hz)
COOLPAK 2200 (60 Hz)

Number of electrical connections for cold heads		1	1
Helium system filling pressure at room temperature	barg	15 ₋₁	14 ₋₁
Ambient temperature	°C (°F)	+5 to +40 (+41 to +104)	+5 to +40 (+41 to +104)
Cooling water consumption	l/min	< 5	< 5
Cooling water feed temperature	°C (°F)	+5 to +25 (+41 to +77)	+5 to +25 (+41 to +77)
Mains voltage (single phase)	V	230 ± 10%	208 ± 10%
Operating current			
with cooled down cold head	A	9.5 to 10.5	11.5 to 12.5
with warmed up cold head	A	12.0	13.0
Electric power consumption			
with cooled down cold head	kW	2.2	2.3
with warmed up cold head	kW	2.4	2.5
Remote control through interface	V DC	24	24
Helium connections			
self-sealing fittings			
high-pressure side (outside thread)		1/2" ¹⁾	1/2" ¹⁾
low-pressure side (outside thread)		1/2" ¹⁾	1/2" ¹⁾
Water connections	DN	10	10
Noise level (at a distance of 1 m (3.5 ft))	dB(A)	< 55	< 55
Dimensions (W x H x D)	mm (in.)	445 x 395 x 400 (17.52 x 15.55 x 15.74)	445 x 395 x 400 (17.52 x 15.55 x 15.74)
Weight, approx.	kg (lbs)	69 (152.32)	69 (152.32)

Ordering Information
COOLPAK 2000 (50 Hz)
COOLPAK 2200 (60 Hz)

	Part No.	Part No.
Compressor unit	840000V2000	840000V2200
Accessories, optional		
Tool-Kit	E20004779	E20004779
Spare parts		
Adsorber CPS-V8	E 840001973	E 840001973

¹⁾ Series 5400 from Aeroquip, coupling size "-8", or compatible types.

Compressor Units for Pneumatically Driven Cold Heads and Pumps, Water Cooling COOLPAK 6000 H/6200 H/6000 HD



Compressor units COOLPAK 6000 H/6200 H/6000 HD

Used to drive cold heads with pneumatically driven displacer pistons, i.e. for individual operation of the COOLPOWER cold heads 140 T and 5/100, but also older cold heads such as the RGS 120, RGD 580 and 1245, as well as the multiplexing of COOLPOWER cold heads 50 and 7/25.

In addition, these compressors are used to operate COOLVAC cryo pumps with integrated cold heads of these types.

Advantages to the User

- Highly effective and even more powerful when connected with Leybold cryo pumps and refrigerators
- Excellent long-term reliability owing to the modular design and the long life components
- Silent and low vibration operation through scroll compressors
- Simple installation and operation
- Global power supply compatibility
- Easy integration in complex systems due to 24 V DC or RS 232 C interfaces
- Almost maintenance-free
- Small footprint
- Low cost of ownership

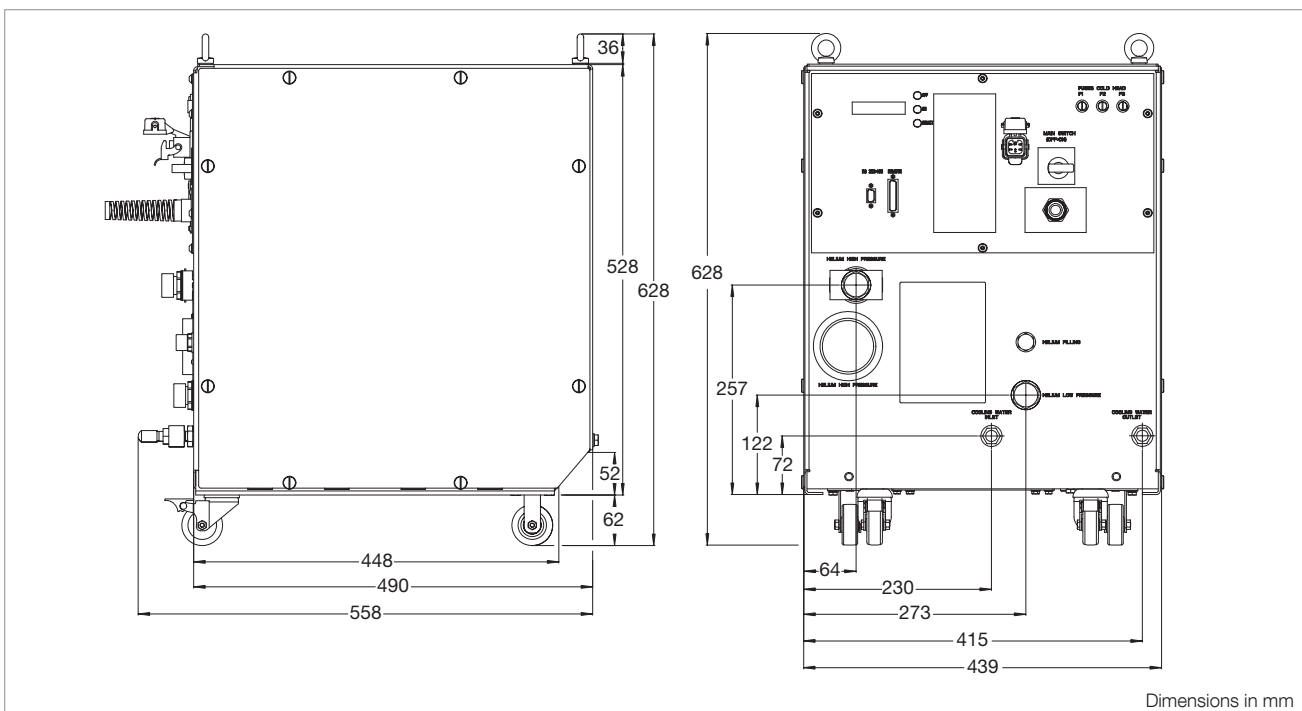

Dimensional drawing for the COOLPAK 6000 H/6200 H/6000 HD

Technical Data

COOLPAK

	6000 H / 6000 HD		6200 H	
	50 Hz	60 Hz	50 Hz	60 Hz
Number of electrical connections for cold heads	1 / 2		1	
Helium system filling pressure at room temperature	17 ₋₁ barg	16 ₋₁	15 ₋₁	14 ₋₁
Ambient temperature	+5 to +40 (+41 to +104) °C (°F)			
Cooling-water consumption ¹⁾	5 l/min			
Cooling-water entry temperature	+5 to +25 (+41 to +77) °C (°F)			
Main voltage (3 phase)				
upon delivery	400 ± 10% V	–	230 ²⁾ + 1% / -10%	230 ± 10%
alternative setting	–	470 ± 10% V	200 ± 10%	200 ± 10%
Operating currents				
with cooled down cold head	10 to 12 A	–	20 to 22	–
with warmed up cold head	11 to 13 A	–	22 to 25	–
Electrical power consumption				
with cooled down cold head	6.5 to 7.5 kW	7.0 to 8.0	6.5 to 7.5	7.0 to 8.0
with warmed up cold head	7.0 to 8.0 kW	7.5 to 8.5	7.0 to 8.0	7.5 to 8.5
Remote control via interface	24 V DC or RS 232 C			
Helium connections				
Self-sealing couplings				
High pressure connection (outside thread)	1/2" ⁴⁾			
Low pressure connection (outside thread)	1/2" ⁴⁾			
Water connections	Hose nozzle DN 12 / G 1/2" outside thread			
Sound level (at 1 m (3.5 ft) distance)	60 dB(A)			
Dimensions (W x H x D)	440 x 589 x 558 mm (17.32 x 23.19 x 21.97) in.)			
Weight, approx.	104 (230) kg (lbs)			

Ordering Information

COOLPAK

	6000 H / 6000 HD		6200 H	
	50 Hz	60 Hz	50 Hz	60 Hz
	Part No.	Part No.	Part No.	Part No.
Compressor unit				
without power supply cable				
Connection for 1 cold head (CP ... H)	840000V6001		840000V6201	
Connection for 2 cold heads (CP ... H)	840000V6004		–	
Power supply cable				
CEE plug, 32 A/6h, 3-pol +N+PE, 3.5 m (12.25 ft)	893 95	–	–	
NEMA plug, L 16-20 P, 20 A/480 V, 3-pol +PE (AWG 12), 3.5 m (12.25 ft)	–	893 96	–	
- with end splice (AWG 10), 10 m (35.0 ft)	840 111		840 111	
- with end splice (AWG 10), 20 m (70.0 ft)	840 112		840 112	
Accessories				
Tool-Kit	E 20004779		E 20004779	
Water cooling discharge throttle	E 840000133 ³⁾		–	
Spare parts				
Adsorber CP6000H	E 840002863			

¹⁾ At a cooling water entry temperature of 25 °C (77 °F).

²⁾ At 14 barg filling pressure.

³⁾ Only for COOLPAK 6000 HD.

⁴⁾ Series 5400 from Aeroquip, coupling size "-8", or compatible types.

Compressor Units for Mechanically Driven Cold Heads and Pumps, Water Cooling COOLPAK 6000 HMD/6200 HMD



Compressor unit COOLPAK 6000 HMD/6200 HMD

Serves the purpose of individually driving the cold heads with mechanically driven displacers; i.e. COOLPOWER 250 MD and 10 MD.

In addition, these compressor units are also used for operating the COOLVAC cryo pumps 30000 BL LN₂ and COOLVAC 60000 BL LN₂.

Advantages to the User

- Highly effective and even more powerful when connected with Leybold cryo pumps and refrigerators
- Excellent long-term reliability owing to the modular design and the long life components
- Silent and low vibration operation through scroll compressors
- Small footprint
- Simple installation and operation
- Global power supply compatibility
- Easy integration in complex systems due to 24 V DC or RS 232 C interfaces
- Variable cold head motor speed, adjustable using keys on the power module or RS232C interface
- Long maintenance-free period of operation

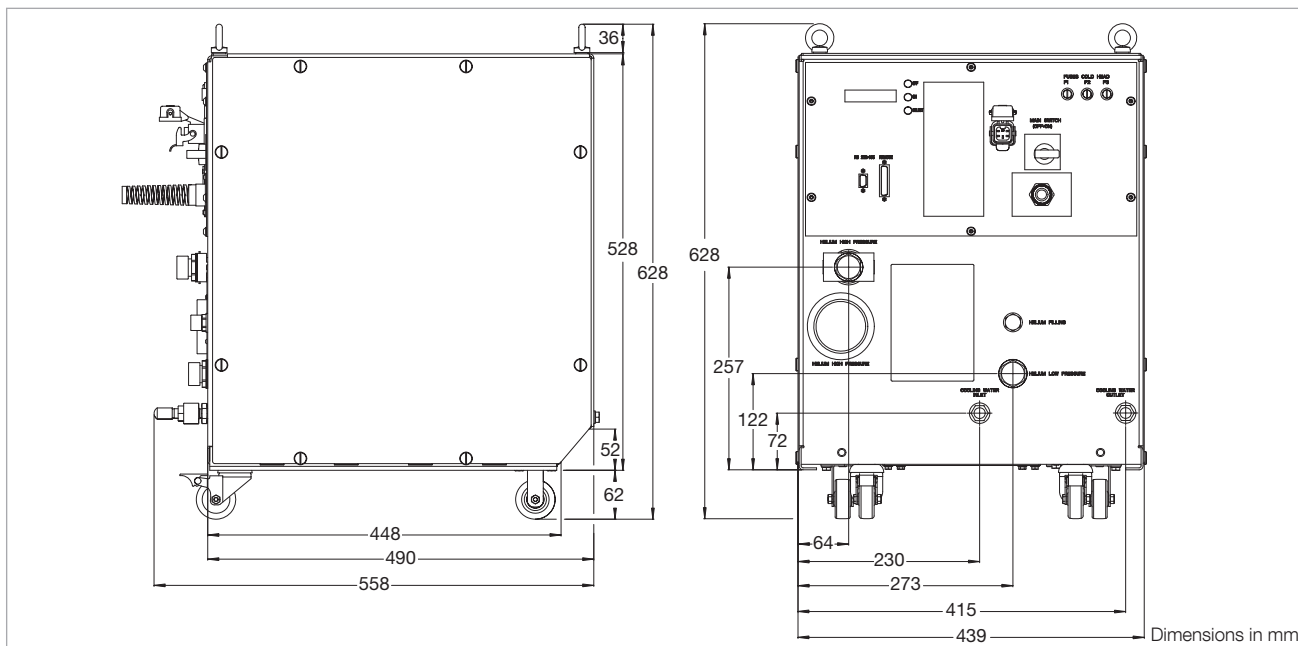

Dimensional drawing for the COOLPAK 6000 HMD/6200 HMD

Technical Data

COOLPAK

		6000 HMD		6200 HMD	
		50 Hz	60 Hz	50 Hz	60 Hz
Mains voltage (3 phase)	V	400 ± 10%	460 ± 10%	200 ± 10%	200 - 230 ± 10%
Helium system filling pressure at room temperature	barg	15 ₋₁	14 ₋₁	14 ₋₁	13 ₋₁
For all other Technical Data, see COOLPAK 6000 H and 6200 H					

Ordering Information

COOLPAK

	6000 HMD	6200 HMD
	Part No.	Part No.
Compressor type		
400 V/3-ph. 50 Hz or	840000V6002	-
460 V/3-ph. 60 Hz ± 10%		
200 V/3-ph. 50 Hz or	-	840000V6202
200-230 V/3-ph. 60 Hz ± 10%		
Flexible pressure line (for operating mechanically driven cold heads)		
9 m (31.5 ft) (High-pressure)	840 217	
FL9 HP-DN 20 (8f/8f)		
9 m (31.5 ft) (Low-pressure)	840218V0032	
FL9 LP-DN 32 (8f/8f)		
20 m (75.0 ft) (High-pressure)	840230V2020	
FL20 HP-DN 20 (8f/8f)		
20 m (75.0 ft) (Low-pressure)	840231V2032	
FL20 LP-DN 32 (8f/8f)		
Connection cable for the cold heads		
COOLPOWER 250 MD, 10 MD		
9,0 m (31.5 ft)	842 110	
20,0 m (75.0 ft)	842 112	
Power supply cable		
CEE plug, 32 A/6h, 3 pol+N+PE,	893 95	-
3,5 m (12.25 ft)		
NEMA plug, L 16-20 P, 20 A/480 V,	893 96	-
3 pol+PE (AWG 12), 3,5 m (12.25 ft)		
10 m (35.0 ft) with end splice (AWG 10)	840 111	
20 m (70.0 ft) with end splice (AWG 10)	840 112	
Accessories		
Tool-Kit	E 20004779	
Water cooling discharge throttle	E 840000133	
Spare parts		
Adsorber CP6000H	E 840002863	

General Accessories for Compressor Units COOLPAK 2000, 6000 H

Technical Data	Length	Connections on both sides (inside thread)	
		High pressure line (HD)	Low pressure line (ND)
Flexlines ^{1), 2)}			
FL 4.5 (1/2", 1/2") (= 1 Set)	4.5 m (14.76 ft)	1/2"	1/2"
FL 9.0 (1/2", 1/2") (= 1 Set)	9,0 m (29.53 ft)	1/2"	1/2"
FL 18.0 HP (1/2") (= single high pressure line)	18 m (59.06 ft)	1/2"	-
FL 18.0 LP (1/2") (= single low pressure line)	18 m (59.06 ft)	-	1/2"

Accessories for Flexlines	Connections (m = Outside thread, f = Inside thread)	
Adaptor for flexlines		
AD (1/2" m, 3/4" f)	1/2" m	3/4" f
AD (1/2" f, 3/4" m)	3/4" m	1/2" f
90°-Elbow 1/2" for flexlines	1/2" m	1/2" f
Coupling 1/2" for interconnecting two 1/2" flexlines	1/2" m	1/2" m
Coupling 3/4"	3/4" m	3/4" m

	Gas Distributors (required quantity)	Gas Manifold - Connections At the compressor (Inside thread)	At the cold head (Outside thread)
	Gas manifold (1 piece each)		
GD 2 (for dual operation) ²⁾	2	1/2"	2 x 1/2"
GD 4 (for up to quad operation) ²⁾	2	1/2"	4 x 1/2"

Ordering Information

General Accessories

	Part No.
Flexlines ^{1), 2)}	
FL 4.5 (1/2", 1/2") (= 1 Set)	892 87
FL 9.0 (1/2", 1/2") (= 1 Set)	892 88
FL 18.0 HP (1/2") (= single high pressure line)	840 203
FL 18.0 LP (1/2") (= single low pressure line)	840 204
Adaptor for flexlines	
AD (1/2" m, 3/4" f)	892 89
AD (1/2" f, 3/4" m)	892 90
90°-Elbow 1/2" for flexlines	891 73
Coupling 1/2" for interconnecting two 1/2" flexlines	891 71
Gas manifold (1 piece each)	
GD 2 (for dual operation) ²⁾	840 253 (2x)
GD 4 (for up to quad operation) ²⁾	840 254 (2x)
Connection cable for linking cold head and compressor unit ²⁾	
Power supply cable 4.5 m (14.76 ft)	E400 000 323
Power supply cable 18 m (59.06 ft)	840 002 964V0018
Extension cable for linking cold head and compressor unit ²⁾	
EL 4.5 (4.5 m / 14.76 ft)	893 74

All flexible pressure lines, adaptor pieces, bends, isolating pieces, line couplings and gas manifolds are equipped with self-sealing Aeroquip fittings and filled in the factory with high-purity helium gas (purity: 99.999%). The filling pressure is 16 barg.

¹⁾ Minimum bending radius: 30 cm (11.81 in.).

²⁾ Only suited for pneumatically driven cold heads and cryo pumps.

Accessories for Cryo Pumps / Cryogenics

Controllers and Monitoring Units for Cryo Pumps

CRYOVISION

Optional Display Unit for COOLVAC iCL Cryo Pumps with COOL.DRIVE pump controller

Advantages to the User

- Visualisation of all *iClassicLine* cryo pump control processes with COOL.DRIVE integrated control unit via the integrated 7" (177.8 mm) touchscreen.
- Interface to customer's system controller for single or multiplex operation for cryo pumps from the *iClassicLine* range
- Output of measurement signals of all pressure and temperature sensors that are connected, along with the display of status reports of all pumps connected to the network
- Easily integrated within customer's system control

Typical Applications

- For automated operation of the COOLVAC cryo pumps of the *iClassicLine*

Control and Display Unit CRYOVISION



The intelligent control unit CRYOVISION automatically controls and monitors up to 10 COOLVAC *iClassicLine* cryo pumps.

Online monitoring, help functions and a service interface for ease of diagnosis and software updates via the built-in USB interface are just a few of its user-friendly features.

The CRYOVISION can be installed as a "stand alone system" or remote controlled via an interface.

Furthermore, an optional ProfiBus module is available for communication with the individual cryo pumps in single and multiplex operation via the Profi-Bus.

Technical specifications

- Deployable as a desktop unit or as a mounted unit in a 19" rack
- Operation via 7" (177.8 mm) touchscreen or rear-sided interfaces

Scope of delivery

- Stylus
- Power supply connector
- Adhesive rubber feet for use as a desktop unit
- Installation kit for 19" rack installation
- Installation and operation manual

Technical Data**CRYOVISION**

Operating voltage, +/-10 %	V DC	24 ¹⁾
Power consumption	W	11
Ambient temperature during operation	°C	+5 - +40
Dimensions (W x H x D)	mm (in.)	213 x 128.5 x 160 (8.39 x 5.06 x 6.3) [1/2 19" 3 HU]
Weight	kg (lbs)	1.9 (4.19)

¹⁾ Provided via the CRYOVISION – COOL.DRIVE control line or optionally via an external, separate power supply.

Ordering Information**CRYOVISION**

	Part No.
Control and Display Unit CRYOVISION	844231V0002

Accessories

Connection line CRYOVISION – COOL.DRIVE / COOL.DRIVE – COOL.DRIVE	
Length	
5 m (16.4 ft)	844231V2005
10 m (32.8 ft)	844231V2010
20 m (65.6 ft)	844231V2020

Optional Interface Module

COOLVAC ProfiBus Module ProfiBus - RS232 converter for COOL.DRIVE und CRYOVISION	844000V1
--	----------

COOLVAC ProfiBus Module

Optional ProfiBus – RS232 converter for COOLVAC iClassicLine cryo pumps with COOL.DRIVE control unit and CRYOVISION display unit

Advantages to the User

- Direct control and monitoring of the current *iClassicLine* range of pumps with COOL.DRIVE controllers using the ProfiBus DP protocol
- Control and monitoring of all *iClassicLine* cryo pumps connected to the CRYOVISION display unit on the network using the ProfiBus DP protocol
- Control and monitoring of older cryo pumps from the ClassicLine range via the corresponding COOLVAC system controller
- Configured as a top-hat rail module for straightforward rack installation.

Typical Applications

- Conversion of Profibus DP commands into RS232 commands and of RS232 response messages into Profibus DP response messages for the RS232 interfaces of the COOL.DRIVE controllers on the *iClassicLine* cryo pumps and/or for the RS232 interfaces of the optional CRYOVISION display unit, and for the RS232 interface of the COOLVAC system controller of the earlier COOLVAC ClassicLine range of cryo pumps.

COOLVAC ProfiBus Module



The COOLVAC ProfiBus module enables the simple and straightforward control and monitoring of cryo pumps from the current *iClassicLine* range and/or the earlier ClassicLine range of pumps via the RS232 interface of the attendant control and display units COOL.DRIVE and CRYOVISION or COOLVAC SC via the Profibus DP standard.

The attendant GSD file is available on our homepage.

Technical specifications

- Plastic casing, ventilated
- Combination installation feet for top-hat and C-section rails
- ProfiBus DP slave interface module
- ProfiBus DP V0 conforming to IEC 61158-2 and IEC 61784 Type 3
- ProfiBus DP address range Hex \$01...\$7D selectable via switches and \$7E selectable via software; corresponds to decimal numbers 1...126.
- ProfiBus terminating resistor can be cut in using a switch in the module
- ProfiBus connection via a 9-way D-sub socket
- RS232 interface lead connection using pluggable screw terminals

Scope of delivery

- ProfiBus module for top-hat rail installation
- 3m RS232 connection lead
- Installation and operating instructions

Technical Data**COOLVAC ProfiBus Module**

Operating voltage, +/-10 %	V DC	24
Power consumption, approx.	mA	90
Ambient temperature during operation	°C	+5 - +40
Dimensions (W x H x D)	mm (in.)	22.5 x 100 x 115 (0.89 x 3.94 x 4.53)
Weight	kg (lbs)	0.13 (0.29)

Ordering Information**COOLVAC ProfiBus Module**

	Part No.
COOLVAC ProfiBus Module	844000V1

COOLVAC iClassicLine, Single System Configuration

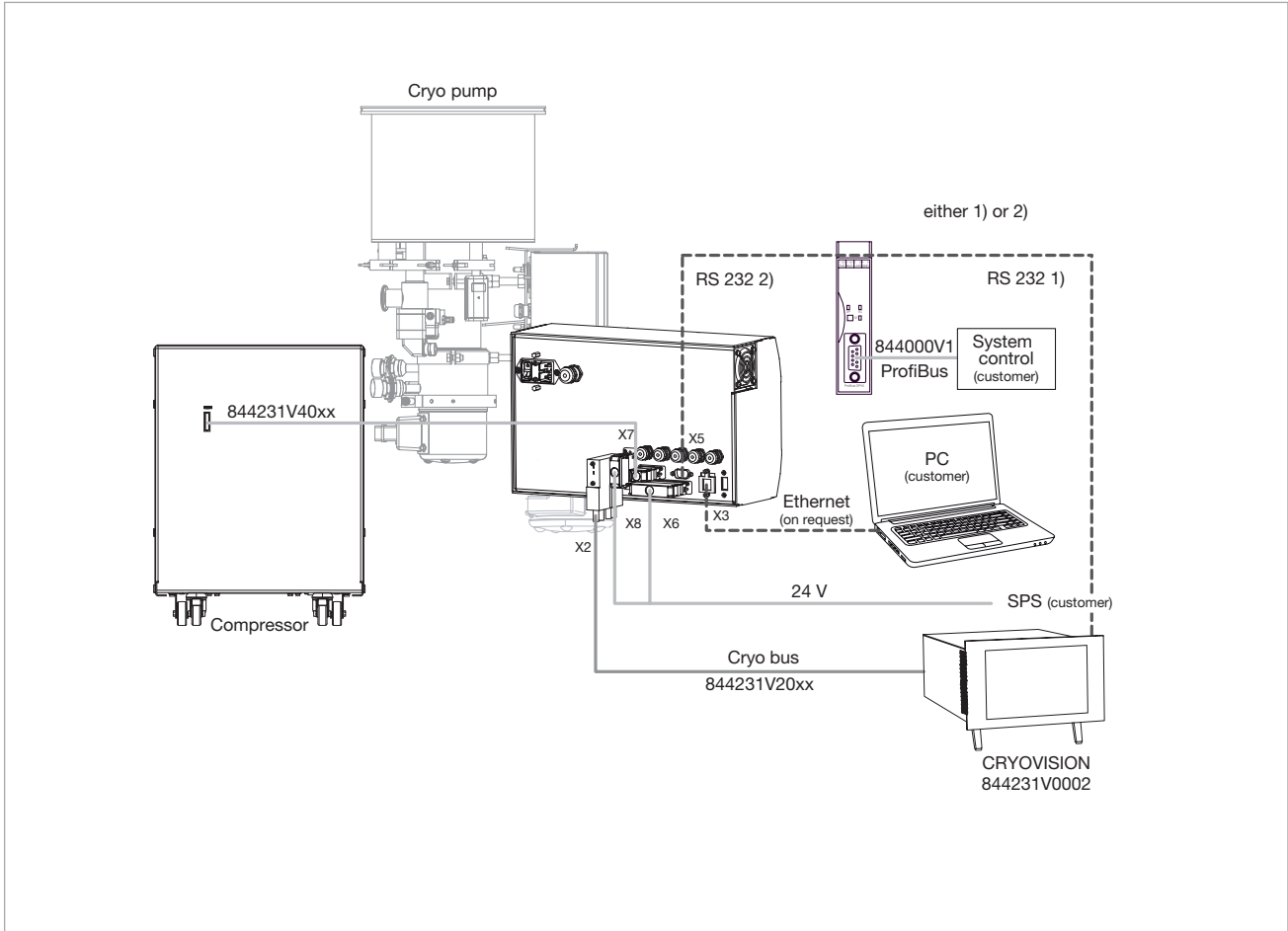

Control options for one pump and one compressor unit

COOLVAC iClassicLine, Dual and Multiple System Configuration

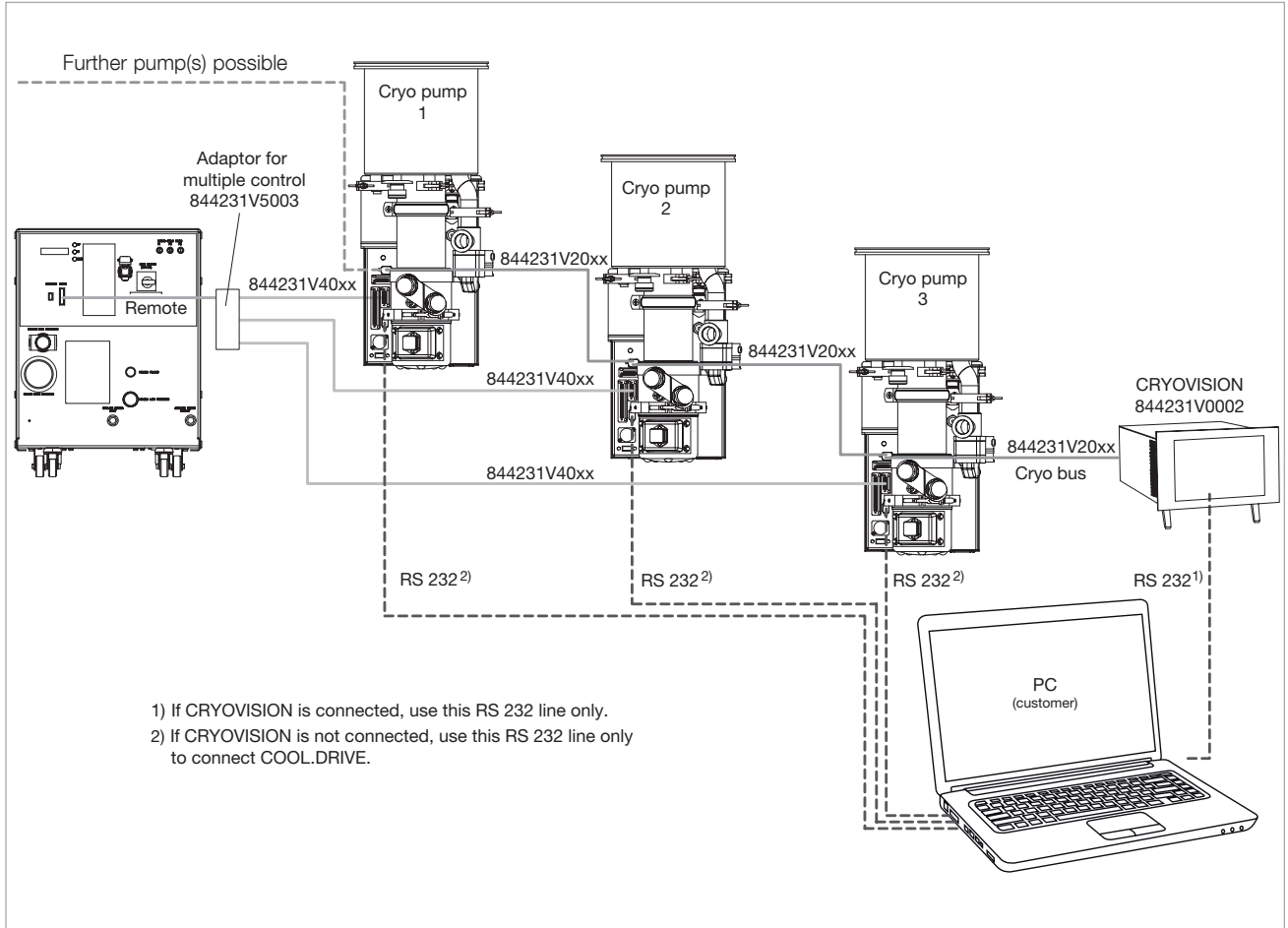

Control options for three pumps

Low Temperature Measuring Instrument MODEL 211S



Advantages to the User

- Supports one silicon diode
- 3-digit LED display
- Temperature readout between 1 and 450 Kelvin
- Two trigger thresholds
- RS 232 C interface

Typical Applications

- Temperature measurements on cryostats
- Temperature measurements on cryo pumps for monitoring their operation and to control pump systems

Technical Data

		MODEL 211S
Measurement current	μA	10
Display		LED, 5-digits
Temperature range	K	1.4 to 475
Resolution		0.001 K from 1.4 to 99.9 K 0.01 K from 100 to 475 K
Accuracy		±0.05 K from 1.5 to 99.9 K ±0.05 K from 100 to 475 K
Power supply voltage		5 V DC at 1 A through the supplied 100-240 V AC power adaptor
Trigger thresholds		2
Switched output		2 relays (n.c. and n.o.) 30 V DC at 1 A
Analog output		
Voltage	V	0 to 10
Current	mA	4 to 20
RS 232 C interface		a) Temperature output b) External adjustment of switching thresholds
Admissible ambient temperature °C (°F)		+15 to +35 (+59 to +95)
Mechanical design/housing		Benchtop unit
Dimensions (W x H x D)	mm (in.)	96 x 48 x 166 (3.78 x 1.89 x 6.54)
Weight (including packaging), approx.	kg (lbs)	0.45 (1.0)

Ordering Information

	Part No.
Low temperature measuring instrument MODEL 211S	844 110
HV cable 2-way with plug, 10 m (35.0 ft) long ¹⁾	844 112
HV cable 4-way with plug, 10 m (35.0 ft) long ²⁾	844 113
UHV cable 4-way with plug, 10 m (35.0 ft) long ²⁾	844 114
Silicon diode, type E, with connecting cable and micro plugs ⁴⁾ - without current feedthrough	844000V5
HV current feedthrough on a flange DN 25 KF, 2-way ⁵⁾	E20019256
UHV current feedthrough on a flange DN 16 CF, 4-way ⁶⁾	500 217

¹⁾ Compatible with HV current feedthrough on a flange DN 25 ISO-KF (E20019256) and for older cryo pumps of type RPK.

²⁾ Compatible with current ranges BasicLine (BL) and BL LN₂.

³⁾ Compatible with UHV current feedthrough on a flange DN16CF (500217) and cryo pumps from the BL-UHV range.

⁴⁾ Compatible with HV current feedthrough (E20019256).

⁵⁾ Compatible with 844000V5 and measurement line 844112.

⁶⁾ Compatible with measurement line 844114.

Temperature Sensor

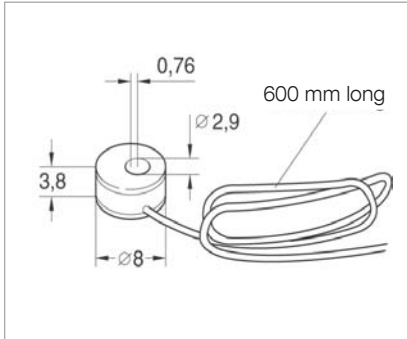

Dimensional drawing for the silicon diode, type E

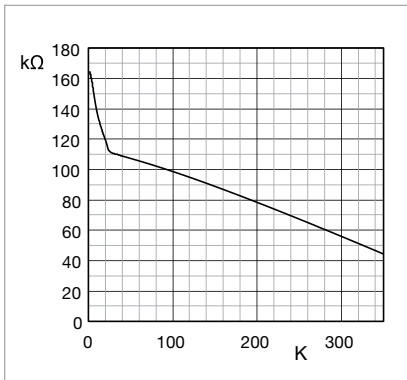

Standard characteristic of the silicon diode

In contrast to vapor pressure thermometers, electric temperature sensors can be used for continuous measurements within a wide range of temperatures.

Silicon diodes offer a negative temperature coefficient of resistance, i.e. their resistance drops as the temperature increases. The slope of the temperature/resistance characteristic and the absolute resistance are decisive regarding the suitability of these diodes. The slope determines the sensitivity of the sensor and a high electrical resistance permits accurate measurements while keeping the thermal load small (microwatts).

In systems which are degassed at high temperatures, silicon diodes can only be fitted after degassing has been completed.

The silicon diode type E matches the low temperature display unit.

Technical Data

Silicon Diode Type E

Temperature range	K	1.4 to 325
Temperature coefficient (dR/dT)		
qualitative		Negative in the entire temperature range
quantitative	Ω/K	Non-linear characteristic
Measurement current	μA	10
Bakeable to	$^{\circ}C$ ($^{\circ}F$)	+60 (+140)

Ordering Information

Silicon Diode Type E

	Part No.
Temperature sensor	844000V5
Silicon diode with 4-way electrical feedthrough	E6512948

Sales and Service

Germany

Leybold GmbH

Sales, Service, Support Center (3SC)
Bonner Strasse 498
D-50968 Cologne
T: +49-(0)221-347 1234
F: +49-(0)221-347 31234
sales@leybold.com
www.leybold.com

Leybold GmbH

Sales Area North

Branch Office Berlin
Industriestrasse 10b
D-12099 Berlin
T: +49-(0)30-435 609 0
F: +49-(0)30-435 609 10
sales.bn@leybold.com

Leybold GmbH

Sales Office South

Branch Office Munich
Karl-Hammerschmidt-Strasse 34
D-85609 Aschheim-Dornach
T: +49-(0)89-357 33 9-10
F: +49-(0)89-357 33 9-33
sales.mn@leybold.com
service.mn@leybold.com

Leybold Dresden GmbH

Service Competence Center

Zur Wetterwarte 50, Haus 304
D-01109 Dresden
Service:
T: +49-(0)351-88 55 00
F: +49-(0)351-88 55 041
info.dr@leybold.com

Europe

Belgium

Leybold Nederland B.V.

Belgisch bijkantoor

Leuvensesteenweg 542-9A
B-1930 Zaventem
Sales:
T: +32-2-711 00 83
F: +32-2-720 83 38
sales.zv@leybold.com
Service:
T: +32-2-711 00 82
F: +32-2-720 83 38
service.zv@leybold.com

France

Leybold France S.A.S.

Parc du Technopolis, Bâtiment Beta
3, Avenue du Canada
F-91940 Les Ulis cedex
Sales and Service:
T: +33-1-69 82 48 00
F: +33-1-69 07 57 38
info.ctb@leybold.com
sales.ctb@leybold.com

Leybold France S.A.S.

Valence Factory
640, Rue A. Bergès
B.P. 107
F-26501 Bourg-lès-Valence Cedex
T: +33-4-75 82 33 00
F: +33-4-75 82 92 69
marketing.vc@leybold.com

Great Britain

Leybold UK LTD.

Unit 9
Silverglade Business Park
Leatherhead Road
Chessington
Surrey (London)
KT9 2QL
Sales:
T: +44-13-7273 7300
F: +44-13-7273 7301
sales.ln@leybold.com
Service:
T: +44-13-7273 7320
F: +44-13-7273 7303
service.ln@leybold.com

Italy

Leybold Italia S.r.l.

Via Trasimeno 8
I-20128 Mailand
Sales:
T: +39-02-27 22 31
F: +39-02-27 20 96 41
sales.mi@leybold.com
Service:
T: +39-02-27 22 31
F: +39-02-27 22 32 17
service.mi@leybold.com

Netherlands

Leybold Nederland B.V.

Floridadreef 102
NL-3565 AM Utrecht
Sales and Service:
T: +31-(30) 242 63 30
F: +31-(30) 242 63 31
sales.ut@leybold.com
service.ut@leybold.com

Switzerland

Leybold Schweiz AG

Hinterbergstrasse 56
CH-6312 Steinhausen
Warehouse and shipping address:
Riedthofstrasse 214
CH-8105 Regensdorf
Sales:
T: +41-44-308 40 50
F: +41-44-302 43 73
sales.zh@leybold.com
Service:
T: +41-44-308 40 62
F: +41-44-308 40 60
service.zh@leybold.com

Spain

Leybold Hispánica, S.A.

C/. Huelva, 7
E-08940 Cornellá de Llobregat
(Barcelona)
Sales:
T: +34-93-666 43 11
F: +34-93-666 43 70
sales.ba@leybold.com
Service:
T: +34-93-666 46 11
F: +34-93-685 43 70
service.ba@leybold.com

America

USA

Leybold USA Inc.

5700 Mellon Road
USA-Export, PA 15632
T: +1-724-327-5700
F: +1-724-325-3577
info.ex@leybold.com
Sales:
T: +1-724-327-5700
F: +1-724-333-1217
Service:
T: +1-724-327-5700
F: +1-724-325-3577

Brazil

Leybold do Brasil

Rod. Vice-Prefeito Hermenegildo Tonolli,
nº. 4413 - 6B
Distrito Industrial
Jundiá - SP
CEP 13.213-086
Sales and Service:
T: +55 11 3395 3180
F: +55 11 99467 5934
sales.ju@leybold.com
service.ju@leybold.com

Asia

P. R. China

Leybold (Tianjin)

International Trade Co. Ltd.
Beichen Economic
Development Area (BEDA),
No. 8 Western Shuangchen Road
Tianjin 300400
China
Sales and Service:
T: +86-22-2697 0808
F: +86-22-2697 4061
F: +86-22-2697 2017
sales.tj@leybold.com
service.tj@leybold.com

India

Leybold India Pvt Ltd.

No. 82(P), 4th Phase
K.I.A.D.B. Plot
Bommasandra Industrial Area
Bangalore - 560 099
Indien
Sales and Service:
T: +91-80-2783 9925
F: +91-80-2783 9926
sales.bgl@leybold.com
service.bgl@leybold.com

Japan

Leybold Japan Co., Ltd.

Headquarters
Shin-Yokohama A.K.Bldg., 4th floor
3-23-3, Shin-Yokohama
Kohoku-ku, Yokohama-shi
Kanagawa-ken 222-0033
Japan
Sales:
T: +81-45-471-3330
F: +81-45-471-3323
sales.yh@leybold.com

Leybold Japan Co., Ltd.

Tsukuba Technical Service Center
1959, Kami-yokoba
Tsukuba-shi, Ibaraki-shi 305-0854
Japan
Service:
T: +81-29 839 5480
F: +81-29 839 5485
service.iik@leybold.com

Malaysia

Leybold Malaysia

Leybold Singapore Pte Ltd.

No. 1 Jalan Hi-Tech 2/6
Kulim Hi-Tech Park
Kulim, Kedah Darul
Aman 09000
Malaysia
Sales and Service:
T: +604 4020 222
F: +604 4020 221
sales.ku@leybold.com
service.ku@leybold.com

South Korea

Leybold Korea Ltd.

3F. Jellzone 2 Tower
Jeongja-dong 159-4
Bundang-gu Sungnam-si
Gyeonggi-do
Bundang 463-384, Korea
Sales:
T: +82-31 785 1367
F: +82-31 785 1359
sales.bd@leybold.com
Service:
623-7, Upsung-Dong
Cheonan-Si
Chungcheongnam-Do
Korea 330-290
T: +82-41 589 3035
F: +82-41 588 0166
service.cn@leybold.com

Singapore

Leybold Singapore Pte Ltd.

8 Commonwealth Lane #01-01
Singapore 149555
Singapore
Sales and Service:
T: +65-6303 7030
F: +65-6773 0039
sales.sg@leybold.com
service.sg@leybold.com

Taiwan

Leybold Taiwan Ltd.

No 416-1, Sec. 3
Chunghsin Rd., Chutung
Hsinchu County 310
Taiwan, R.O.C.
Sales and Service:
T: +886-3-500 1688
F: +886-3-583 3999
sales.hc@leybold.com
service.hc@leybold.com

Headquarter

Leybold GmbH

Bonner Strasse 498
D-50968 Cologne
T: +49-(0)221-347-0
F: +49-(0)221-347-1250
info@leybold.com



www.leybold.com